

The MPC9229 is a 3.3 V compatible, PLL based clock synthesizer targeted for high performance clock generation in mid-range to high-performance telecom, networking and computing applications. With output frequencies from 25 MHz to 400 MHz and the support of differential PECL output signals the device meets the needs of the most demanding clock applications.

### Features

- 25 MHz to 400 MHz Synthesized Clock Output Signal
- Differential PECL Output
- LVCMOS Compatible Control Inputs
- On-Chip Crystal Oscillator for Reference Frequency Generation
- 3.3-V Power Supply
- Fully Integrated PLL
- Minimal Frequency Overshoot
- Serial 3-Wire Programming Interface
- Parallel Programming Interface for Power-Up
- 32-Lead LQFP and 28-Lead PLCC Packaging
- 32-Lead and 28-Lead Pb-Free Package
- SiGe Technology
- Ambient Temperature Range 0°C to +70°C
- Pin and Function Compatible to the MC12429
- **Replacement part: ICS84329B**

### Functional Description

The internal crystal oscillator uses the external quartz crystal as the basis of its frequency reference. The frequency of the internal crystal oscillator is divided by 16 and then multiplied by the PLL. The VCO within the PLL operates over a range of 800 to 1600 MHz. Its output is scaled by a divider that is configured by either the serial or parallel interfaces. The crystal oscillator frequency  $f_{XTAL}$ , the PLL feedback-divider M and the PLL post-divider N determine the output frequency.

The feedback path of the PLL is internal. The PLL adjusts the VCO output frequency to be 4·M times the reference frequency by adjusting the VCO control voltage. Note that for some values of M (either too high or too low) the PLL will not achieve phase lock. The PLL will be stable if the VCO frequency is within the specified VCO frequency range (800 to 1600 MHz). The M-value must be programmed by the serial or parallel interface.

The PLL post-divider N is configured through either the serial or the parallel interfaces, and can provide one of four division ratios (1, 2, 4, or 8). This divider extends performance of the part while providing a 50% duty cycle. The output driver is driven differentially from the output divider, and is capable of driving a pair of transmission lines terminated 50 Ω to  $V_{CC} - 2.0$  V. The positive supply voltage for the internal PLL is separated from the power supply for the core logic and output drivers to minimize noise induced jitter.

The configuration logic has two sections: serial and parallel. The parallel interface uses the values at the M[8:0] and N[1:0] inputs to configure the internal counters. It is recommended on system reset to hold the P\_LOAD input LOW until power becomes valid. On the LOW-to-HIGH transition of P\_LOAD, the parallel inputs are captured. The parallel interface has priority over the serial interface. Internal pullup resistors are provided on the M[8:0] and N[1:0] inputs prevent the LVCMOS compatible control inputs from floating.

The serial interface centers on a fourteen bit shift register. The shift register shifts once per rising edge of the S\_CLOCK input. The serial input S\_DATA must meet setup and hold timing as specified in the AC Characteristics section of this document. The configuration latches will capture the value of the shift register on the HIGH-to-LOW edge of the S\_LOAD input. Refer to [Programming Interface](#) for more information. The TEST output reflects various internal node values, and is controlled by the T[2:0] bits in the serial data stream. In order to minimize the PLL jitter, it is recommended to avoid active signal on the TEST output.

## MPC9229

### 400 MHz LOW VOLTAGE CLOCK SYNTHESIZER

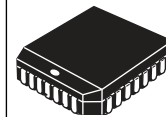

**EI SUFFIX**  
28-LEAD PLCC PACKAGE  
Pb-FREE PACKAGE  
CASE 776-02



**AC SUFFIX**  
32-LEAD LQFP PACKAGE  
Pb-FREE PACKAGE  
CASE 873A-04

### ORDERING INFORMATION

Device	Temp. Range	Case No.	Package
MPC9229EI	0°C to +70°C	776-02	PLCC
MPC9229AC	0°C to +70°C	873A-03	LQFP

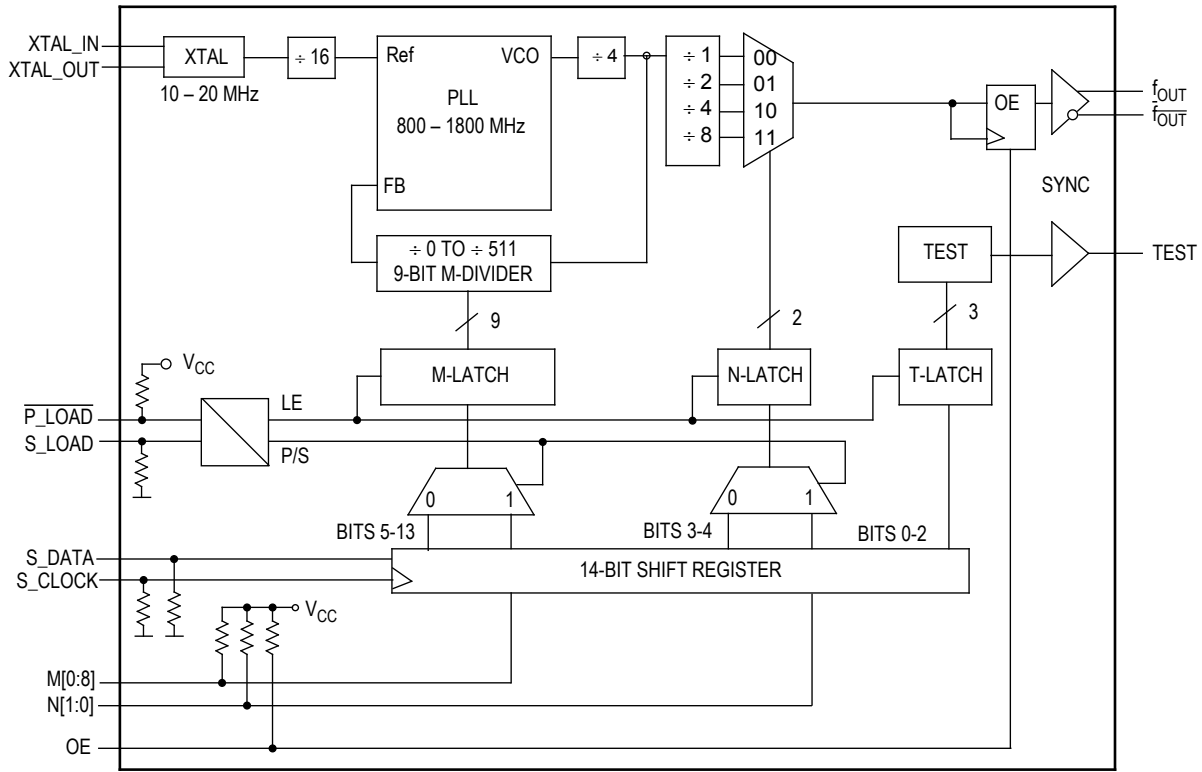

Figure 1. MPC9229 Logic Diagram

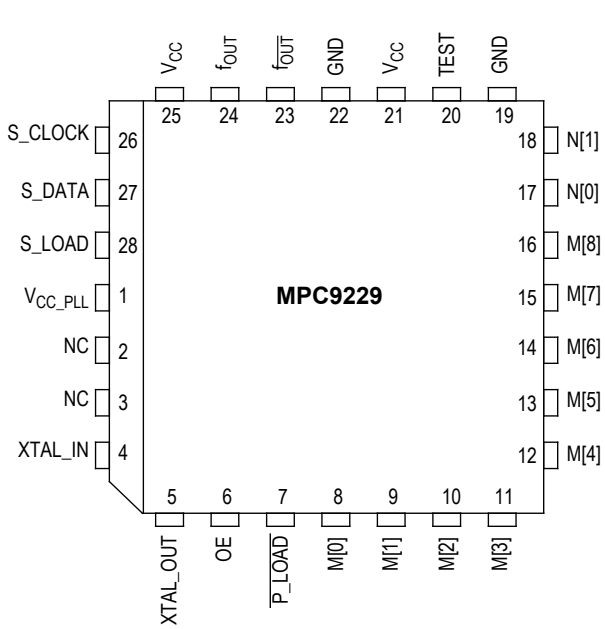

Figure 2. MPC9229 28-Lead PLCC Pinout (Top View)

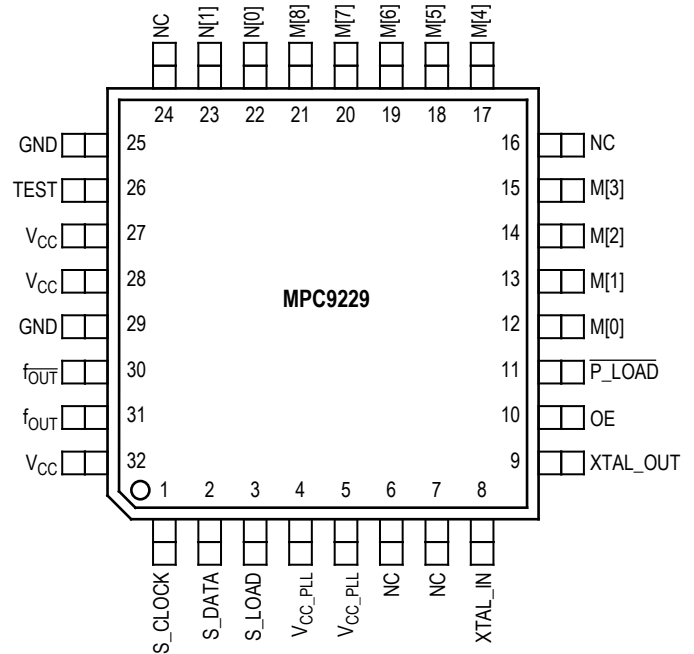

Figure 3. MPC9229 32-Lead LQFP Pinout (Top View)

**Table 1. Pin Configurations**

Pin	I/O	Default	Type	Function
XTAL_IN, XTAL_OUT	—	—	Analog	Crystal oscillator interface
$f_{OUT}$ , $f_{\overline{OUT}}$	Output	—	LVPECL	Differential clock output
TEST	Output	—	LVC MOS	Test and device diagnosis output
S_LOAD	Input	0	LVC MOS	Serial configuration control input This inputs controls the loading of the configuration latches with the contents of the shift register. The latches will be transparent when this signal is high, thus the data must be stable on the high-to-low transition
P_LOAD	Input	1	LVC MOS	Parallel configuration control input This input controls the loading of the configuration latches with the content of the parallel inputs (M and N). The latches will be transparent when this signal is low, thus the parallel data must be stable on the low-to-high transition of P_LOAD. P_LOAD is state sensitive
S_DATA	Input	0	LVC MOS	Serial configuration data input
S_CLOCK	Input	0	LVC MOS	Serial configuration clock input
M[0:8]	Input	1	LVC MOS	Parallel configuration for PLL feedback divider (M). M is sampled on the low-to-high transition of $\overline{P\_LOAD}$ .
N[1:0]	Input	1	LVC MOS	Parallel configuration for Post-PLL divider (N) N is sampled on the low-to-high transition of $\overline{P\_LOAD}$
OE	Input	1	LVC MOS	Output enable (active high). The output enable is synchronous to the output clock to eliminate the possibility of runt pulses on the $f_{OUT}$ output. OE = L low stops $f_{OUT}$ in the logic low state ( $f_{OUT} = L$ , $f_{\overline{OUT}} = H$ )
GND	Supply	Supply	Ground	Negative power supply (GND).
$V_{CC}$	Supply	Supply	$V_{CC}$	Positive power supply for I/O and core. All $V_{CC}$ pins must be connected to the positive power supply for correct operation.
$V_{CC\_PLL}$	Supply	Supply	$V_{CC}$	PLL positive power supply (analog power supply).

**Table 2. Output Frequency Range and PII Post-Divider N**

N		Output Division	Output Frequency Range
1	0		
0	0	1	200 – 400 MHz
0	1	2	100 – 200 MHz
1	0	4	50 – 100 MHz
1	1	8	25 – 50 MHz

**Table 3. General Specifications**

Symbol	Characteristics	Min	Typ	Max	Unit	Condition
$V_{TT}$	Output Termination Voltage	—	$V_{CC} - 2$	—	V	—
MM	ESD Protection (Machine Model)	200	—	—	V	—
HBM	ESD Protection (Human Body Model)	2000	—	—	V	—
LU	Latch-Up Immunity	200	—	—	mA	—
$C_{IN}$	Input Capacitance	—	4.0	—	pF	Inputs
$\theta_{JA}$	LQFP 32 Thermal Resistance Junction to Ambient JESD 51-3, Single Layer Test Board	—	83.1	86.0	°C/W	Natural Convection
		—	73.3	75.4	°C/W	100 ft/min
		—	68.9	70.9	°C/W	200 ft/min
		—	63.8	65.3	°C/W	400 ft/min
		—	57.4	59.6	°C/W	800 ft/min
	JESD 51-6, 2S2P Multilayer Test Board	—	59.0	60.6	°C/W	Natural Convection
		—	54.4	55.7	°C/W	100 ft/min
		—	52.5	53.8	°C/W	200 ft/min
		—	50.4	51.5	°C/W	400 ft/min
		—	47.8	48.8	°C/W	800 ft/min
$\theta_{JC}$	LQFP 32 Thermal Resistance Junction to Case	—	23.0	26.3	°C/W	MIL-SPEC 883E Method 1012.1

**Table 4. Absolute Maximum Ratings<sup>(1)</sup>**

Symbol	Characteristics	Min	Max	Unit
$V_{CC}$	Supply Voltage	-0.3	3.9	V
$V_{IN}$	DC Input Voltage	-0.3	$V_{CC} + 0.3$	V
$V_{OUT}$	DC Output Voltage	-0.3	$V_{CC} + 0.3$	V
$I_{IN}$	DC Input Current	—	±20	mA
$I_{OUT}$	DC Output Current	—	±50	mA
$T_S$	Storage Temperature	-65	125	°C

1. Absolute maximum continuous ratings are those maximum values beyond which damage to the device may occur. Exposure to these conditions or conditions beyond those indicated may adversely affect device reliability. Functional operation at absolute-maximum-rated conditions is not implied.

**Table 5. DC Characteristics ( $V_{CC} = 3.3\text{ V} \pm 5\%$ ,  $T_A = 0^\circ\text{C}$  to  $+70^\circ\text{C}$ )**

Symbol	Characteristics	Min	Typ	Max	Unit	Condition
LVCMOS Control Inputs ( $\overline{P\_LOAD}$ , $S\_LOAD$ , $S\_DATA$ , $S\_CLOCK$ , $M[0:8]$ , $N[0:1]$ , $OE$ )						
$V_{IH}$	Input High Voltage	2.0	—	$V_{CC} + 0.3$	V	LVCMOS
$V_{IL}$	Input Low Voltage	—	—	0.8	V	LVCMOS
$I_{IN}$	Input Current <sup>(1)</sup>	—	—	±200	μA	$V_{IN} = V_{CC}$ or GND
Differential Clock Output $f_{OUT}$ <sup>(2)</sup>						
$V_{OH}$	Output High Voltage <sup>(3)</sup>	$V_{CC} - 1.11$	—	$V_{CC} - 0.74$	V	LVPECL
$V_{OL}$	Output Low Voltage <sup>(3)</sup>	$V_{CC} - 1.95$	—	$V_{CC} - 1.60$	V	LVPECL
Test and Diagnosis Output TEST						
$V_{OH}$	Output High Voltage <sup>(3)</sup>	2.0	—	—	V	$I_{OH} = -0.8\text{ mA}$
$V_{OL}$	Output Low Voltage <sup>(3)</sup>	—	—	0.55	V	$I_{OL} = 0.8\text{ mA}$
Supply Current						
$I_{CC\_PLL}$	Maximum PLL Supply Current	—	—	20	mA	$V_{CC\_PLL}$ Pins
$I_{CC}$	Maximum Supply Current	—	—	100	mA	All $V_{CC}$ Pins

1. Inputs have pull-down resistors affecting the input current.

2. Outputs terminated  $50\ \Omega$  to  $V_{TT} = V_{CC} - 2\text{ V}$ .

3. The MPC9229 TEST output levels are compatible to the MC12429 output levels.

**Table 6. AC Characteristics** ( $V_{CC} = 3.3\text{ V} \pm 5\%$ ,  $T_A = 0^\circ\text{C}$  to  $+70^\circ\text{C}$ )<sup>(1)</sup>

Symbol	Characteristics	Min	Typ	Max	Unit	Condition	
$f_{XTAL}$	Crystal Interface Frequency Range	10	—	20	MHz	—	
$f_{VCO}$	VCO Frequency Range <sup>(2)</sup>	800	—	1600	MHz	—	
$f_{MAX}$	Output Frequency	N = 00 ( $\div 1$ )	—	400	MHz	—	
		N = 01 ( $\div 2$ )	100	200	MHz	—	
		N = 10 ( $\div 4$ )	50	100	MHz	—	
		N = 11 ( $\div 8$ )	25	50	MHz	—	
DC	Output Duty Cycle	45	50	55	%	—	
$t_r, t_f$	Output Rise/Fall Time	0.05	—	0.3	ns	20% to 80%	
$f_{S\_CLOCK}$	Serial Interface Programming Clock Frequency <sup>(3)</sup>	0	—	10	MHz	—	
$t_{P\_MIN}$	Minimum Pulse Width (S_LOAD, $\overline{P\_LOAD}$ )	50	—	—	ns	—	
$t_S$	Setup Time	S_DATA to S_CLOCK	20	—	—	ns	—
		S_CLOCK to S_LOAD	20	—	—	ns	—
		M, N to $\overline{P\_LOAD}$	20	—	—	ns	—
$t_S$	Hold Time	S_DATA to S_CLOCK	20	—	—	ns	—
		M, N to $\overline{P\_LOAD}$	20	—	—	ns	—
$t_{JIT(CC)}$	Cycle-to-Cycle Jitter	N = 00 ( $\div 1$ )	—	90	ps	—	
		N = 01 ( $\div 2$ )	—	130	ps	—	
		N = 10 ( $\div 4$ )	—	160	ps	—	
		N = 11 ( $\div 8$ )	—	190	ps	—	
$t_{JIT(PER)}$	Period Jitter	N = 00 ( $\div 1$ )	—	70	ps	—	
		N = 01 ( $\div 2$ )	—	120	ps	—	
		N = 10 ( $\div 4$ )	—	140	ps	—	
		N = 11 ( $\div 8$ )	—	170	ps	—	
$t_{LOCK}$	Maximum PLL Lock Time	—	—	10	ms	—	

1. AC characteristics apply for parallel output termination of  $50\ \Omega$  to  $V_{TT}$ .

2. The input frequency  $f_{XTAL}$  and the PLL feedback divider M must match the VCO frequency range:  $f_{VCO} = f_{XTAL} \cdot M \div 4$ .

3. The frequency of S\_CLOCK is limited to 10 MHz in serial programming mode. S\_CLOCK can be switched at higher frequencies when used as test clock in test mode 6. Refer to [Applications Information](#) for more details.

## PROGRAMMING INTERFACE

### Programming the MPC9229

Programming the MPC9229 amounts to properly configuring the internal PLL dividers to produce the desired synthesized frequency at the output. The output frequency can be represented by this formula:

$$f_{OUT} = (f_{XTAL} \div 16) \cdot (4 \cdot M) \div (4 \cdot N) \text{ or} \quad (1)$$

$$f_{OUT} = (f_{XTAL} \div 16) \cdot M \div N \quad (2)$$

where  $f_{XTAL}$  is the crystal frequency, M is the PLL feedback-divider and N is the PLL post-divider. The input frequency and the selection of the feedback divider M is limited by the VCO-frequency range.

$f_{XTAL}$  and M must be configured to match the VCO frequency range of 800 to 1600 MHz in order to achieve stable PLL operation:

$$M_{MIN} = 4 \cdot f_{VCO,MIN} \div f_{XTAL} \text{ and} \quad (3)$$

$$M_{MAX} = 4 \cdot f_{VCO,MAX} \div f_{XTAL} \quad (4)$$

For instance, the use of a 16 MHz input frequency requires the configuration of the PLL feedback divider between M = 200 and M = 400. Table 7. shows the usable VCO frequency and M divider range for other example input frequencies. Assuming that a 16 MHz input frequency is used, equation (2) reduces to:

$$f_{OUT} = M \div N$$

**Table 7. MPC9229 Frequency Operating Range**

M	M[8:0]	VCO frequency for a crystal interface frequency of						Output frequency for $f_{XTAL} = 16$ MHz and for N =			
		10	12	14	16	18	20	1	2	4	16
160	010100000						800				
170	010101010						850				
180	010110100					810	900				
190	010111110					855	950				
200	011001000				800	900	1000	200	100	50	25
210	011010010				840	945	1050	210	105	52.5	26.25
220	011011100				880	990	1100	220	110	55	27.50
230	011100110			805	920	1035	1150	230	115	57.5	28.75
240	011110000			840	960	1080	1200	240	120	60	30
250	011111010			875	1000	1125	1250	250	125	62.5	31.25
260	100000100			910	1040	1170	1300	260	130	65	32.50
270	100001110		810	945	1080	1215	1350	270	135	67.5	33.75
280	100011000		840	980	1120	1260	1400	280	140	70	35
290	100100010		870	1015	1160	1305	1450	290	145	72.5	36.25
300	100101100		900	1050	1200	1350	1500	300	150	75	37.5
310	100110110		930	1085	1240	1395	1550	310	155	77.5	38.75
320	101000000	800	960	1120	1280	1440	1600	320	160	80	40
330	101001010	825	990	1155	1320	1485		330	165	82.5	41.25
340	101010100	850	1020	1190	1360	1530		340	170	85	42.5
350	101011110	875	1050	1225	1400	1575		350	175	87.5	43.75
360	101101000	900	1080	1260	1440			360	180	90	45
370	101110010	925	1110	1295	1480			370	185	92.5	46.25
380	101111100	950	1140	1330	1520			380	190	95	47.5
390	110000110	975	1170	1365	1560			390	195	97.5	48.75
400	110010000	1000	1200	1400	1600			400	200	100	50
410	110011010	1025	1230	1435							
420	110100100	1050	1260	1470							
430	110101110	1075	1290	1505							
440	110111000	1100	1320	1540							
450	111000010	1125	1350	1575							
510	111111110	1275	1530								

Substituting N for the four available values for N (1, 2, 4, 8) yields:

**Table 8. Output Frequency Range for  $f_{XTAL} = 16$  MHz**

N			$f_{OUT}$	$f_{OUT}$ Range	$f_{OUT}$ Step
1	0	Value			
0	0	1	M	200 – 400 MHz	1 MHz
0	1	2	$M \div 2$	100 – 200 MHz	500 kHz
1	0	4	$M \div 4$	50 – 100 MHz	250 kHz
1	1	8	$M \div 8$	25 – 50 MHz	125 kHz

**Example Frequency Calculation for an 16 MHz Input Frequency**

If an output frequency of 131 MHz was desired the following steps would be taken to identify the appropriate M and N values. According to Table 8., 131 MHz falls in the frequency set by an value of 2 so  $N[1:0] = 01$ . For  $N = 2$  the output frequency is  $f_{OUT} = M \div 2$  and  $M = f_{OUT} \times 2$ . Therefore  $M = 2 \times 131 = 262$ , so  $M[8:0] = 10000110$ . Following this procedure a user can generate any whole frequency between 25 MHz and 400 MHz. Note that for  $N > 2$  fractional values of can be realized. The size of the programmable frequency steps (and thus the indicator of the fractional output frequencies achievable) will be equal to:

$$f_{STEP} = f_{XTAL} \div 16 \div N$$

**APPLICATIONS INFORMATION**

**Using the Parallel and Serial Interface**

The M and N counters can be loaded either through a parallel or serial interface. The parallel interface is controlled via the  $\overline{P\_LOAD}$  signal such that a LOW-to-HIGH transition will latch the information present on the  $M[8:0]$  and  $N[1:0]$  inputs into the M and N counters. When the  $\overline{P\_LOAD}$  signal is LOW, the input latches will be transparent and any changes on the  $M[8:0]$  and  $N[1:0]$  inputs will affect the  $f_{OUT}$  output pair. To use the serial port, the  $S\_CLOCK$  signal samples the information on the  $S\_DATA$  line and loads it into a 14-bit shift register. Note that the  $\overline{P\_LOAD}$  signal must be HIGH for the serial load operation to function. The Test register is loaded with the first three bits, the N register with the next two and the M register with the final eight bits of the data stream on the  $S\_DATA$  input. For each register the most significant bit is loaded first (T2, N1, and M8). A pulse on the  $S\_LOAD$  pin after the shift register is fully loaded will transfer the divide values into the counters. The HIGH-to-LOW transition on the  $S\_LOAD$  input will latch the new divide values into the counters. Figure 3. illustrates the timing diagram for both a parallel and a serial load of the MPC9229 synthesizer.  $M[8:0]$  and  $N[1:0]$  are normally specified once at power-up through the parallel interface, and then possibly again through the serial interface. This approach allows the application to come up at one frequency and then change or fine-tune the clock as the ability to control the serial interface becomes available.

**Using the Test and Diagnosis Output TEST**

The TEST output provides visibility for one of the several internal nodes as determined by the  $T[2:0]$  bits in the serial configuration stream. It is not configurable through the parallel interface. Although it is possible to select the node that represents  $f_{OUT}$ , the CMOS output is not able to toggle fast enough for higher output frequencies and should only be used for test and diagnosis. The T2, T1, and T0 control bits are preset to '000' when  $\overline{P\_LOAD}$  is LOW so that the PECL  $f_{OUT}$  outputs are as jitter-free as possible. Any active signal on the TEST output pin will have detrimental affects on the jitter of the PECL output pair. In normal operations, jitter specifications are only guaranteed if the TEST output is static. The serial configuration port can be used to select one of the alternate functions for this pin. Most of the signals available on the TEST output pin are useful only

for performance verification of the MPC9229 itself. However the PLL bypass mode may be of interest at the board level for functional debug. When  $T[2:0]$  is set to 110, the MPC9229 is placed in PLL bypass mode. In this mode the  $S\_CLOCK$  input is fed directly into the M and N dividers. The N divider drives the  $f_{OUT}$  differential pair and the M counter drives the TEST output pin. In this mode the  $S\_CLOCK$  input could be used for low speed board level functional test or debug. Bypassing the PLL and driving  $f_{OUT}$  directly gives the user more control on the test clocks sent through the clock tree. Figure 5. shows the functional setup of the PLL bypass mode. Because the  $S\_CLOCK$  is a CMOS level, the input frequency is limited to 200 MHz. This means the fastest the  $f_{OUT}$  pin can be toggled via the  $S\_CLOCK$  is 100 MHz as the divide ratio of the Post-PLL divider is 2 (if  $N = 1$ ). Note that the M counter output on the TEST output will not be a 50% duty cycle.

**Table 9. Test and Debug Configuration for TEST**

T[2:0]			TEST Output
T2	T1	T0	
0	0	0	14-bit shift register out <sup>(1)</sup>
0	0	1	Logic 1
0	1	0	$f_{XTAL} \div 16$
0	1	1	M-Counter out
1	0	0	$f_{OUT}$
1	0	1	Logic 0
1	1	0	M-Counter out in PLL-bypass mode
1	1	1	$f_{OUT} \div 4$

1. Clocked out at the rate of  $S\_CLOCK$

**Table 10. Debug Configuration for PLL Bypass<sup>(1)</sup>**

Output	Configuration
$f_{OUT}$	$S\_CLOCK \div N$
TEST	M-Counter out <sup>(2)</sup>

1.  $T[2:0] = 110$ . AC specifications do not apply in PLL bypass mode  
 2. Clocked out at the rate of  $S\_CLOCK \div (4 \cdot N)$



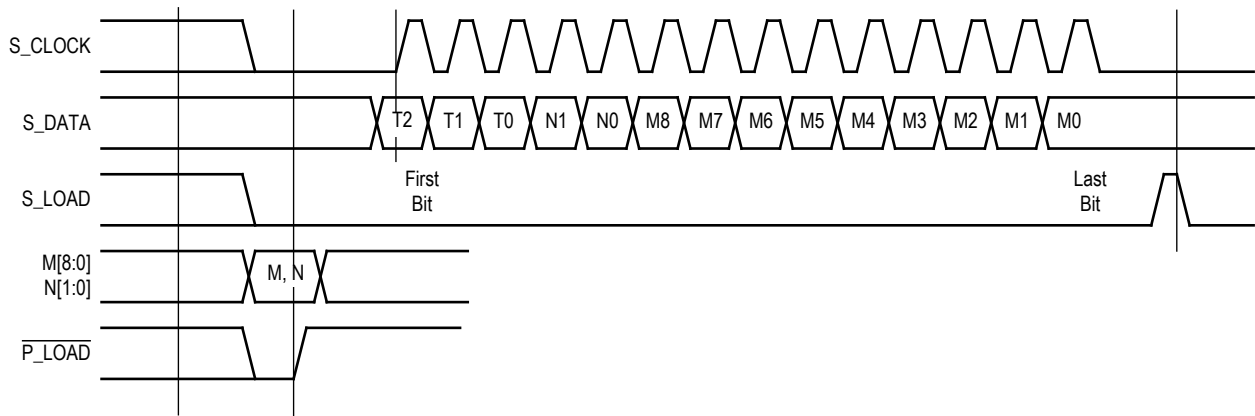

Figure 3. Serial Interface Timing Diagram

**Power Supply Filtering**

The MPC9229 is a mixed analog/digital product. Its analog circuitry is naturally susceptible to random noise, especially if this noise is seen on the power supply pins. Random noise on the  $V_{CC\_PLL}$  pin impacts the device characteristics. The MPC9229 provides separate power supplies for the digital circuitry ( $V_{CC}$ ) and the internal PLL ( $V_{CC\_PLL}$ ) of the device. The purpose of this design technique is to try and isolate the high switching noise digital outputs from the relatively sensitive internal analog phase-locked loop. In a controlled environment such as an evaluation board, this level of isolation is sufficient. However, in a digital system environment where it is more difficult to minimize noise on the power supplies a second level of isolation may be required. The simplest form of isolation is a power supply filter on the  $V_{CC\_PLL}$  pin for the MPC9229. Figure 4. illustrates a typical power supply filter scheme. The MPC9229 is most susceptible to noise with spectral content in the 1 kHz to 1 MHz range. Therefore, the filter should be designed to target this range. The key parameter that needs to be met in the final filter design is the DC voltage drop that will be seen between the  $V_{CC}$  supply and the MPC9229 pin of the MPC9229. From the data sheet the  $V_{CC\_PLL}$  current (the current sourced through the  $V_{CC\_PLL}$  pin) is maximum 20 mA, assuming that a minimum of 2.835 V must be maintained on the  $V_{CC\_PLL}$  pin. The resistor shown in Figure 4. must have a resistance of 10-15  $\Omega$  to meet the voltage drop criteria. The RC filter pictured will provide a broadband filter with approximately 100:1 attenuation for noise whose spectral content is above 20 kHz. As the noise frequency crosses the series resonant point of an individual capacitor its overall impedance begins to look inductive and thus increases with increasing frequency. The parallel capacitor combination shown ensures that a low impedance path to ground exists for frequencies well above the bandwidth of the PLL. Generally, the resistor/capacitor filter will be cheaper, easier to implement and provide an adequate level of supply filtering. A higher level of attenuation can be achieved by replacing the resistor with an appropriate valued inductor. A 1000  $\mu$ H choke will show a significant impedance at 10 kHz frequencies and above. Because of the current draw and the voltage that must be maintained on the  $V_{CC\_PLL}$  pin, a low DC resistance inductor is required (less than 15  $\Omega$ ).

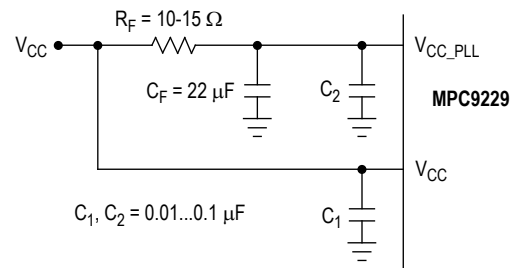
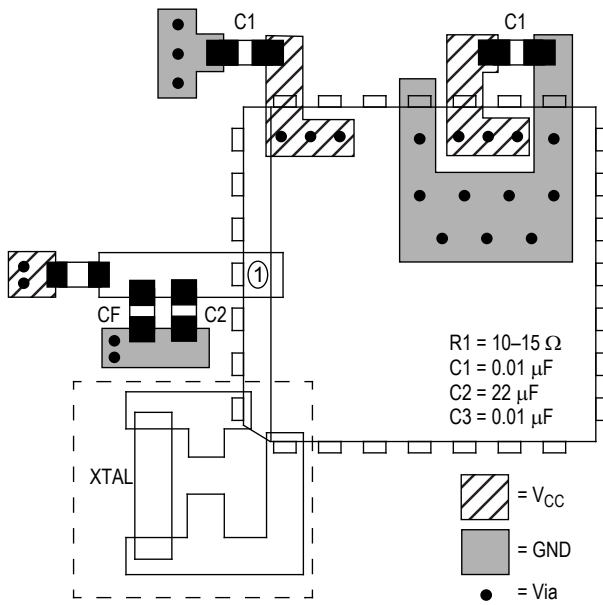

Figure 4.  $V_{CC\_PLL}$  Power Supply Filter

**Layout Recommendations**

The MPC9229 provides sub-nanosecond output edge rates and thus a good power supply bypassing scheme is a must. Figure 5. shows a representative board layout for the MPC9229. There exists many different potential board layouts and the one pictured is but one. The important aspect of the layout in Figure 5. is the low impedance connections between  $V_{CC}$  and GND for the bypass capacitors. Combining good quality general purpose chip capacitors with good PCB layout techniques will produce effective capacitor resonances at frequencies adequate to supply the instantaneous switching current for the MPC9229 outputs. It is imperative that low inductance chip capacitors are used; it is equally important that the board layout does not introduce back all of the inductance saved by using the leadless capacitors. Thin interconnect traces between the capacitor and the power plane should be avoided and multiple large vias should be used to tie the capacitors to the buried power planes. Fat interconnect and large vias will help to minimize layout induced inductance and thus maximize the series resonant point of the bypass capacitors. Note the dotted lines circling the crystal oscillator connection to the device. The oscillator is a series resonant circuit and the voltage amplitude across the crystal is relatively small. It is imperative that no actively switching signals cross under the crystal as crosstalk energy coupled to these lines could significantly impact the jitter of the device. Special attention should be paid to the layout of the crystal to ensure a stable, jitter free interface between the crystal and the on-board oscillator. Although the MPC9229 has several design features to minimize the susceptibility to power supply noise (isolated power and grounds and fully differential PLL), there still may be applications in which overall performance is being degraded due to system power supply noise. The power supply filter and bypass schemes discussed in this section should be adequate to eliminate power supply noise related problems in most designs.





**Figure 5. PCB Board Layout Recommendation for the PLCC28 Package**

**Using the On-Board Crystal Oscillator**

The MPC9229 features a fully integrated on-board crystal oscillator to minimize system implementation costs. The oscillator is a series resonant, multivibrator type design as opposed to the more common parallel resonant oscillator design. The series resonant design provides better stability and eliminates the need for large on chip capacitors. The oscillator is totally self contained so that the only external component required is the crystal. As the oscillator is somewhat sensitive to loading on its inputs the user is advised to mount the crystal as close to the MPC9229 as possible to avoid any board level parasitics. To facilitate co-location surface mount crystals are recommended, but not required. Because the series resonant design is affected by capacitive loading on the XTAL

terminals loading variation introduced by crystals from different vendors could be a potential issue. For crystals with a higher shunt capacitance, it may be required to place a resistance across the terminals to suppress the third harmonic. Although typically not required, it is a good idea to layout the PCB with the provision of adding this external resistor. The resistor value will typically be between 500 and 1 KΩ.

The oscillator circuit is a series resonant circuit and thus for optimum performance a series resonant crystal should be used. Unfortunately most crystals are characterized in a parallel resonant mode. Fortunately there is no physical difference between a series resonant and a parallel resonant crystal. The difference is purely in the way the devices are characterized. As a result a parallel resonant crystal can be used with the MPC9229 with only a minor error in the desired frequency. A parallel resonant mode crystal used in a series resonant circuit will exhibit a frequency of oscillation a few hundred ppm lower than specified, a few hundred ppm translates to kHz inaccuracies. In a general computer application this level of inaccuracy is immaterial. Table 11. below specifies the performance requirements of the crystals to be used with the MPC9229.

**Table 11. Recommended Crystal Specifications**

Parameter	Value
Crystal Cut	Fundamental AT Cut
Resonance	Series Resonance <sup>(1)</sup>
Frequency Tolerance	±75 ppm at 25°C
Frequency/Temperature Stability	±150 pm 0 to 70°C
Operating Range	0 to 70°C
Shunt Capacitance	5 – 7pF
Equivalent Series Resistance (ESR)	50 to 80 Ω
Correlation Drive Level	100 μW
Aging	5 ppm/Yr (First 3 Years)

1. Refer to the accompanying text for series versus parallel resonant discussion.

PACKAGE DIMENSIONS

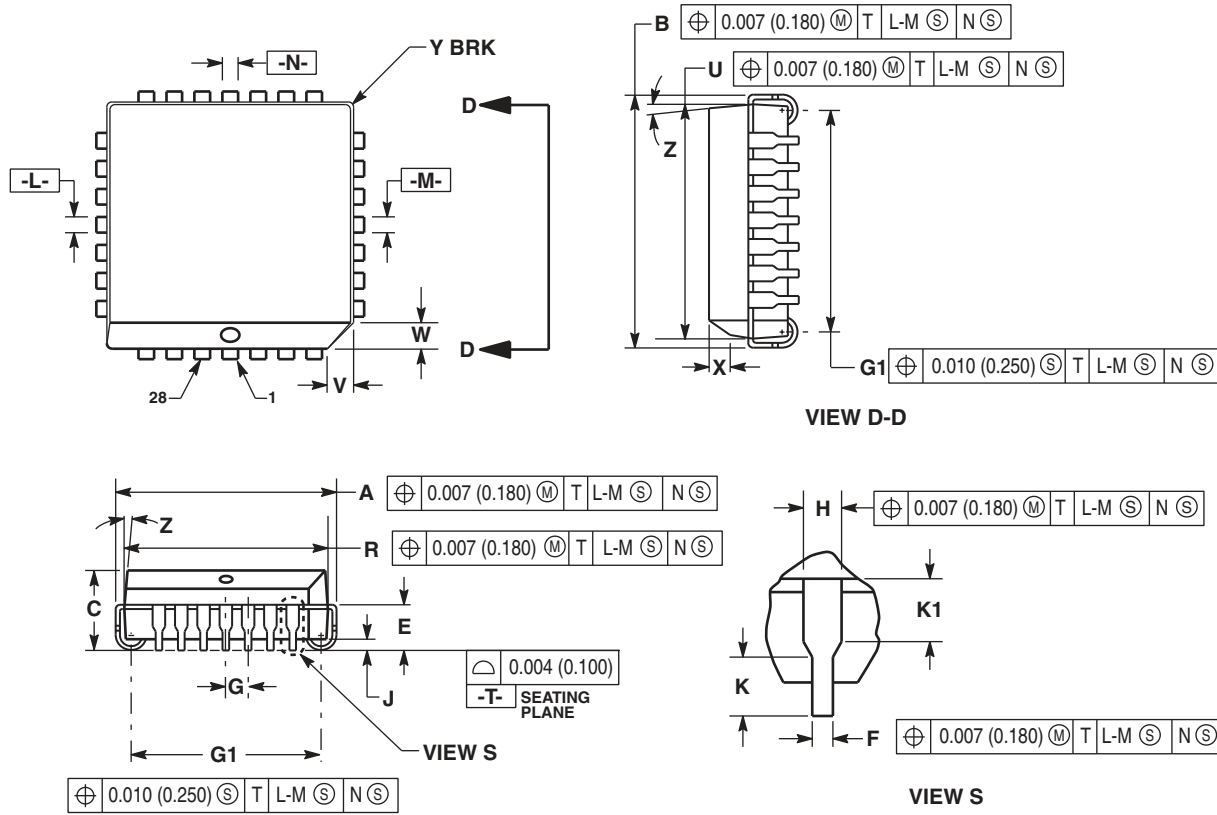

NOTES:

- DATUMS -L-, -M-, AND -N- DETERMINED WHERE TOP OF LEAD SHOULDER EXISTS PLASTIC BODY AT MOLD PARTING LINE.
- DIMENSION G1, TRUE POSITION TO BE MEASURED AT DATUM -T-, SEATING PLANE.
- DIMENSIONS R AND U DO NOT INCLUDE MOLD FLASH. ALLOWABLE MOLD FLASH IS 0.010 (0.250) PER SIDE.
- DIMENSIONING AND TOLERANCING PER ANSI Y14.5M, 1982.
- CONTROLLING DEMENSION: INCH.
- THE PACKAGE TOP MAY BE SMALLER THAN THE PACKAGE BOTTOM BY UP TO 0.012 (0.300). DIMENSIONS R AND U ARE DETERMINED AT THE OUTERMOST EXTREMES OF THE PLASTIC BODY EXCLUSIVE OF MOLD FLASH, TIE BAR BURRS, GATE BURRS AND INTERLEAD FLASH, BUT INCLUDING ANY MISMATCH BETWEEN THE TOP AND BOTTOM OF THE PLASTIC BODY.
- DIMENSION H DOES NOT INCLUDE DAMBAR PROTRUSION OR INTRUSION. THE DAMBAR PROTRUSION(S) SHALL NOT CAUSE THE H DIMENSION TO BE GREATER THAN 0.037 (0.940). THE DAMBAR INTRUSION(S) SHALL NOT CAUSE THE H DIMENSION TO BE SMALLER THAN 0.025 (0.635).

DIM	INCHES		MILLIMETERS	
	MIN	MAX	MIN	MAX
A	0.485	0.495	12.32	12.57
B	0.485	0.495	12.32	12.57
C	0.165	0.180	4.20	4.57
E	0.090	0.110	2.29	2.79
F	0.013	0.019	0.33	0.48
G	0.050 BSC		1.27 BSC	
H	0.026	0.032	0.66	0.81
J	0.020	---	0.51	---
K	0.025	---	0.64	---
R	0.450	0.456	11.43	11.58
U	0.450	0.456	11.43	11.58
V	0.042	0.048	1.07	1.21
W	0.042	0.048	1.07	1.21
X	0.042	0.056	1.07	1.42
Y	---	0.020	---	0.50
Z	2'	10'	2'	10'
G1	0.410	0.430	10.42	10.92
K1	0.040	---	1.02	---

CASE 776-02  
ISSUE D  
28-LEAD PLCC PACKAGE

PACKAGE DIMENSIONS

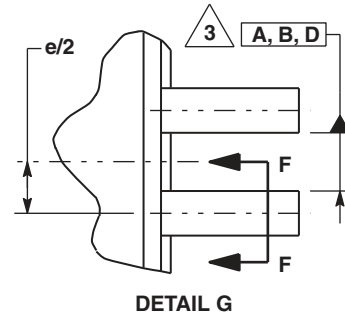
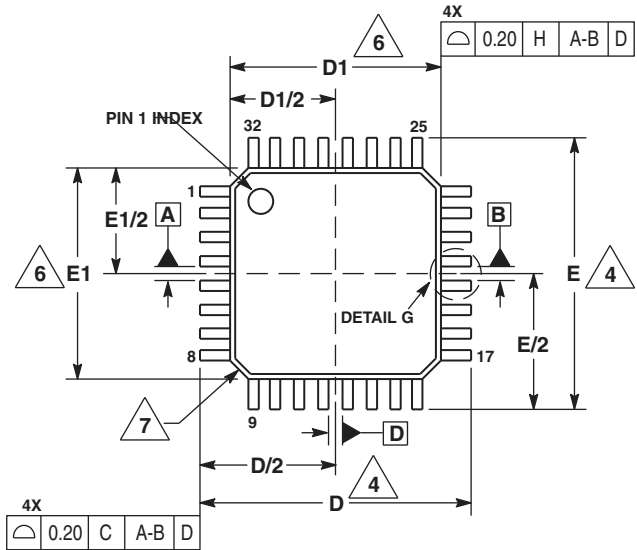

- NOTES:
- DIMENSIONS ARE IN MILLIMETERS.
  - INTERPRET DIMENSIONS AND TOLERANCES PER ASME Y14.5M, 1994.
  - DATUMS A, B, AND D TO BE DETERMINED AT DATUM PLANE H.
  - DIMENSIONS D AND E TO BE DETERMINED AT SEATING PLANE C.
  - DIMENSION b DOES NOT INCLUDE DAMBAR PROTRUSION. ALLOWABLE DAMBAR PROTRUSION SHALL NOT CAUSE THE LEAD WIDTH TO EXCEED THE MAXIMUM b DIMENSION BY MORE THAN 0.08-mm. DAMBAR CANNOT BE LOCATED ON THE LOWER RADIUS OR THE FOOT. MINIMUM SPACE BETWEEN PROTRUSION AND ADJACENT LEAD OR PROTRUSION: 0.07-mm.
  - DIMENSIONS D1 AND E1 DO NOT INCLUDE MOLD PROTRUSION. ALLOWABLE PROTRUSION IS 0.25-mm PER SIDE. D1 AND E1 ARE MAXIMUM PLASTIC BODY SIZE DIMENSIONS INCLUDING MOLD MISMATCH.
  - EXACT SHAPE OF EACH CORNER IS OPTIONAL.
  - THESE DIMENSIONS APPLY TO THE FLAT SECTION OF THE LEAD BETWEEN 0.1-mm AND 0.25-mm FROM THE LEAD TIP.

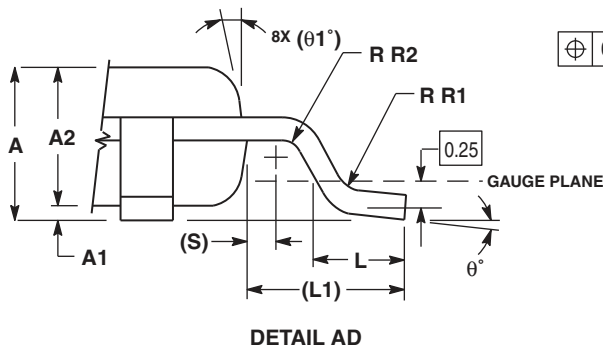
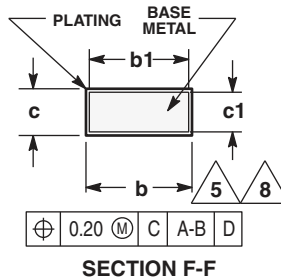
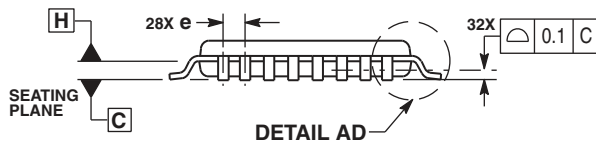

DIM	MILLIMETERS	
	MIN	MAX
A	1.40	1.60
A1	0.05	0.15
A2	1.35	1.45
b	0.30	0.45
b1	0.30	0.40
c	0.09	0.20
c1	0.09	0.16
D	9.00 BSC	
D1	7.00 BSC	
e	0.80 BSC	
E	9.00 BSC	
E1	7.00 BSC	
L	0.50	0.70
L1	1.00 REF	
q	0°	7°
q1	12 REF	
R1	0.08	0.20
R2	0.08	---
S	0.20 REF	

CASE 873A-03  
ISSUE B  
32-LEAD LQFP PACKAGE

PACKAGE DIMENSIONS

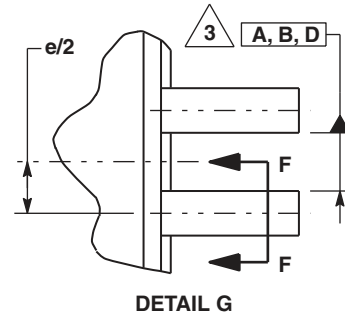
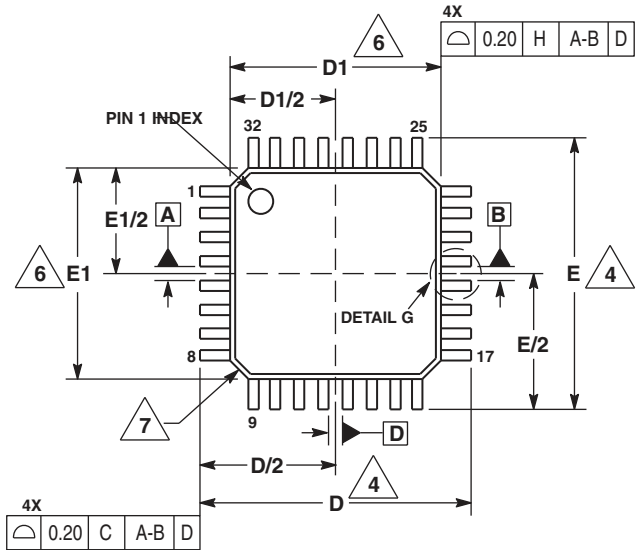

- NOTES:
- DIMENSIONS ARE IN MILLIMETERS.
  - INTERPRET DIMENSIONS AND TOLERANCES PER ASME Y14.5M, 1994.
  - DATUMS A, B, AND D TO BE DETERMINED AT DATUM PLANE H.
  - DIMENSIONS D AND E TO BE DETERMINED AT SEATING PLANE C.
  - DIMENSION b DOES NOT INCLUDE DAMBAR PROTRUSION. ALLOWABLE DAMBAR PROTRUSION SHALL NOT CAUSE THE LEAD WIDTH TO EXCEED THE MAXIMUM b DIMENSION BY MORE THAN 0.08-mm. DAMBAR CANNOT BE LOCATED ON THE LOWER RADIUS OR THE FOOT. MINIMUM SPACE BETWEEN PROTRUSION AND ADJACENT LEAD OR PROTRUSION: 0.07-mm.
  - DIMENSIONS D1 AND E1 DO NOT INCLUDE MOLD PROTRUSION. ALLOWABLE PROTRUSION IS 0.25-mm PER SIDE. D1 AND E1 ARE MAXIMUM PLASTIC BODY SIZE DIMENSIONS INCLUDING MOLD MISMATCH.
  - EXACT SHAPE OF EACH CORNER IS OPTIONAL.
  - THESE DIMENSIONS APPLY TO THE FLAT SECTION OF THE LEAD BETWEEN 0.1-mm AND 0.25-mm FROM THE LEAD TIP.

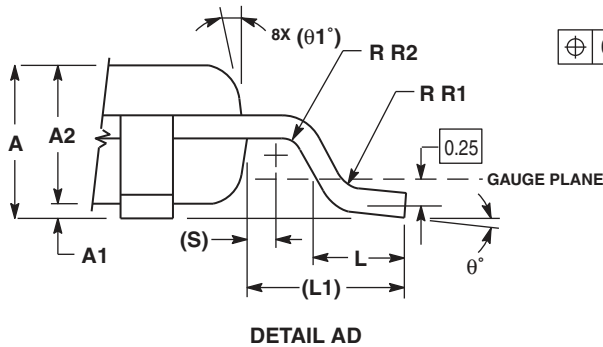
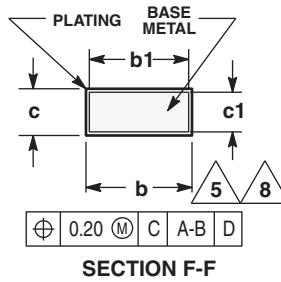
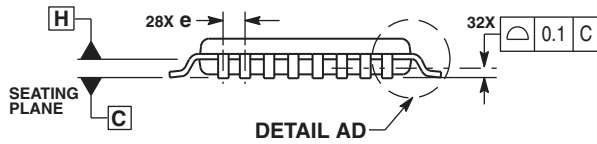

DIM	MILLIMETERS	
	MIN	MAX
A	1.40	1.60
A1	0.05	0.15
A2	1.35	1.45
b	0.30	0.45
b1	0.30	0.40
c	0.09	0.20
c1	0.09	0.16
D	9.00 BSC	
D1	7.00 BSC	
e	0.80 BSC	
E	9.00 BSC	
E1	7.00 BSC	
L	0.50	0.70
L1	1.00 REF	
q	0°	7°
q1	12 REF	
R1	0.08	0.20
R2	0.08	---
S	0.20 REF	

CASE 873A-03  
ISSUE B  
32-LEAD LQFP PACKAGE

## Revision History Sheet

Rev	Table	Page	Description of Change	Date
3	5	4	Per PCN N0611-01, changed Mimimum $V_{OH} = V_{CC} - 1.02V$ to $V_{CC} - 1.11V$ .	10/19/2012
5		1	Per PDN N-12-24, Product Discontinuance Notice - Last Time Buy Expires on (12/3/13)	12/19/12



## IMPORTANT NOTICE AND DISCLAIMER

RENESAS ELECTRONICS CORPORATION AND ITS SUBSIDIARIES (“RENESAS”) PROVIDES TECHNICAL SPECIFICATIONS AND RELIABILITY DATA (INCLUDING DATASHEETS), DESIGN RESOURCES (INCLUDING REFERENCE DESIGNS), APPLICATION OR OTHER DESIGN ADVICE, WEB TOOLS, SAFETY INFORMATION, AND OTHER RESOURCES “AS IS” AND WITH ALL FAULTS, AND DISCLAIMS ALL WARRANTIES, EXPRESS OR IMPLIED, INCLUDING, WITHOUT LIMITATION, ANY IMPLIED WARRANTIES OF MERCHANTABILITY, FITNESS FOR A PARTICULAR PURPOSE, OR NON-INFRINGEMENT OF THIRD PARTY INTELLECTUAL PROPERTY RIGHTS.

These resources are intended for developers skilled in the art designing with Renesas products. You are solely responsible for (1) selecting the appropriate products for your application, (2) designing, validating, and testing your application, and (3) ensuring your application meets applicable standards, and any other safety, security, or other requirements. These resources are subject to change without notice. Renesas grants you permission to use these resources only for development of an application that uses Renesas products. Other reproduction or use of these resources is strictly prohibited. No license is granted to any other Renesas intellectual property or to any third party intellectual property. Renesas disclaims responsibility for, and you will fully indemnify Renesas and its representatives against, any claims, damages, costs, losses, or liabilities arising out of your use of these resources. Renesas' products are provided only subject to Renesas' Terms and Conditions of Sale or other applicable terms agreed to in writing. No use of any Renesas resources expands or otherwise alters any applicable warranties or warranty disclaimers for these products.

(Disclaimer Rev.1.0 Mar 2020)

### Corporate Headquarters

TOYOSU FORESIA, 3-2-24 Toyosu,  
Koto-ku, Tokyo 135-0061, Japan  
[www.renesas.com](http://www.renesas.com)

### Contact Information

For further information on a product, technology, the most up-to-date version of a document, or your nearest sales office, please visit:  
[www.renesas.com/contact/](http://www.renesas.com/contact/)

### Trademarks

Renesas and the Renesas logo are trademarks of Renesas Electronics Corporation. All trademarks and registered trademarks are the property of their respective owners.