

SOLDER SUFFIX	CUSTOMER TERMINAL	RoHS	LEAD(Pb)-FREE	6C(6F)
LF1	Sn100%	Yes	Yes	

more than you expect

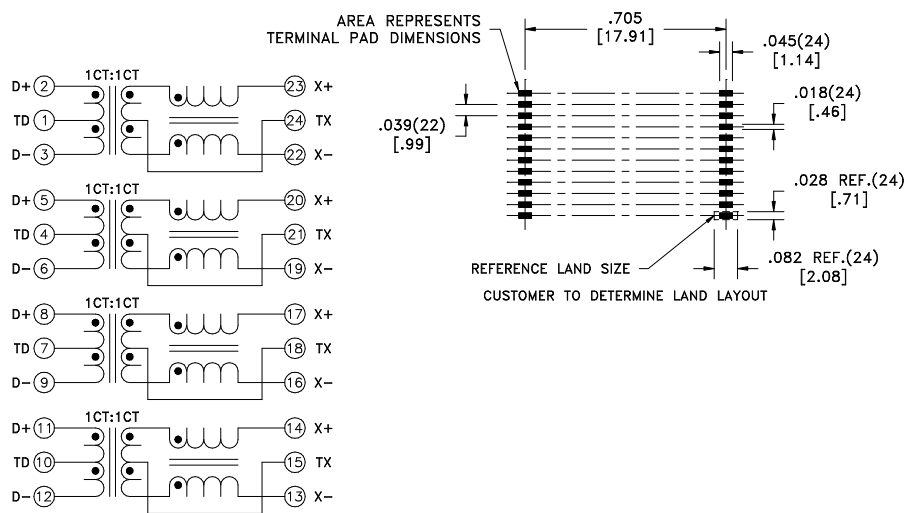
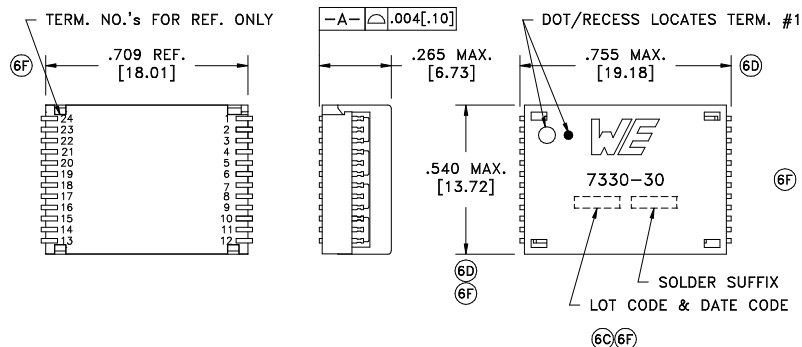

ELECTRICAL SPECIFICATIONS @ 25°C unless otherwise noted:

- INSERTION LOSS: -1.0dB max., 1M - 100MHz.
- DIELECTRIC RATING: 1500Vrms, 1 minute tested by applying 1800Vrms for 1 second between 1-24(tie 1+4+7+10, 15+18+21+24).
- INDUCTANCE: 350uH min., 100kHz, 100mVAC, 8mADC, 23-22; 20-19; 17-16; 14-13, Lp.
- RETURN LOSS: -18dB min., 1M - 40MHz. -16dB min., 50MHz.
-12dB min., 60M - 80MHz. -10dB min., 100MHz.
- URNS RATIO: (2-3):(23-22) = 1:1, ±2%.
(5-6):(20-19) = 1:1, ±2%.
(8-9):(17-16) = 1:1, ±2%.
(11-12):(14-13) = 1:1, ±2%.
- CROSSTALK: -45dB min., 30MHz. -40dB min., 60MHz.
-35dB min., 100MHz.
- DCMR: -43dB min., 30MHz. -37dB min., 60MHz.
-33dB min., 100MHz.
- OPERATING TEMPERATURE RANGE: -40°C to +85°C.
- COPLANARITY: All 24 terminals must lie on a plane within .004 [.10] of Surface A after lead tinning.

6D

REV.	DATE	Packaging Specifications		Tolerances unless otherwise specified: Angles: ±1° Decimals: ±.005 [.13] Fractions: ±1/64 Footprint: ±.005 [.13]	DRAWING TITLE TRANSFORMER EDSO-G24	PART NO. 000-7330-30R-LF1	
6F	10/10	Method: Tape & Reel (6E)					
6E	8/08	PKG-0704					
6D	6/08	www.we-online.com/midcom					
6C	7/07	SEE REVISION SHEET FOR REVISION LEVEL		This drawing is dual dimensioned. Dimensions in brackets are in millimeters.	eiSos p/n: 749020015 (6C)	compliant 	SPECIFICATION SHEET 1 OF 1