

## Single-Supply, 1mA, 2MHz, Single Rail-to-Rail Operational Amplifier

### Features

- Gain Bandwidth Product                    2 MHz (typ.)
- Low Supply Current                         1 mA (typ.)
- Single Supply Operation                  2.4 V to 6.0 V
- Low Input Bias Current                    10 pA (typ.)
- No External Capacitors Required
- Rail-to-Rail Input and Output Swing

### Applications

- Automotive
- Portable Equipment
- Photodiode Amplifier
- Analog Filters
- Notebook and PDAs
- Battery-Powered System

### Available Package

- SOT-23-5L
- SOP-8
- RoHS Compliant

### General Description

The CS6A6291 is a single rail-to-rail input and output operational amplifier which has low supply current and low input bias current. It has wide supply voltage operating range from 2.4 V to 6.0 V.

The rail-to-rail input and output swings provided by the CS6A6291 makes it easy to perform both high-side and low-side sensing, which makes it a good choice for temperature, position and pressure sensors, or any low power applications that require high precision and long term stability.

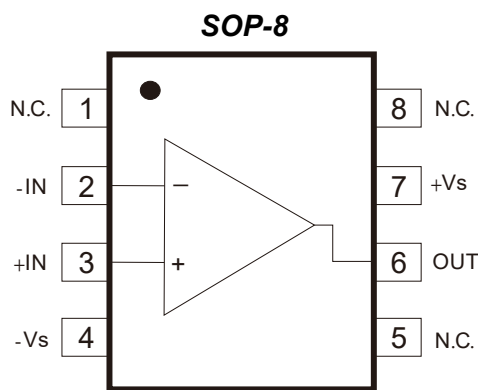

N.C. = No Connect

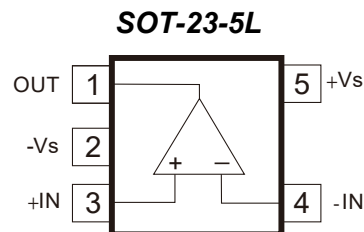

▪ **Package Outline Dimension (SOT-23-5L)**

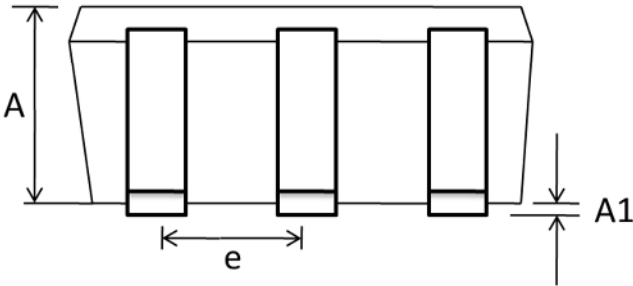
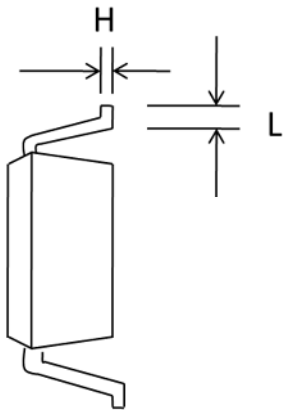
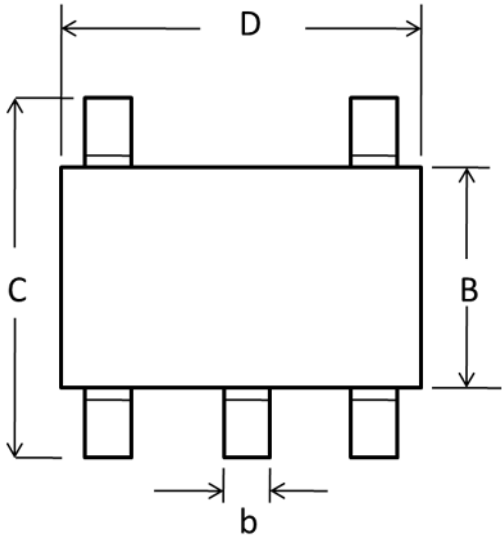

Dimension	Millimeter	
	Min.	Max.
A	0.889	1.295
A1	0.000	0.152
B	1.397	1.803
b	0.356	0.559
C	2.591	2.997
D	2.692	3.099
e	0.838	1.041
H	0.080	0.254
L	0.300	0.610

■ Package Outline Dimension (SOP-8)

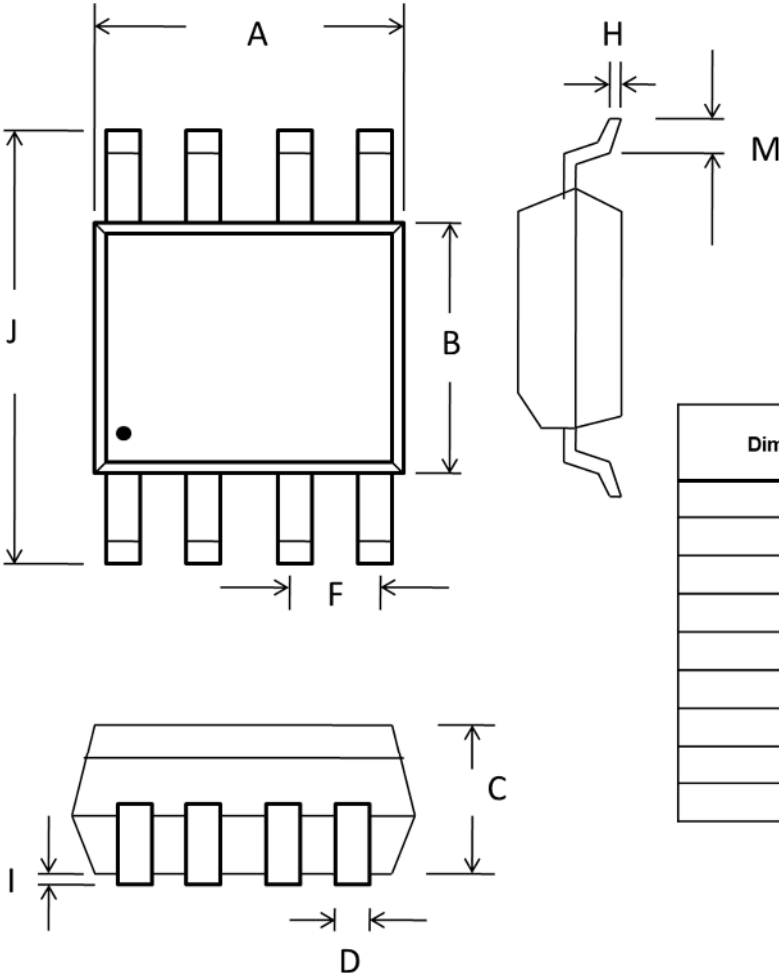

Dimension	Millimeter	
	Min.	Max.
A	4.801	5.004
B	3.810	3.988
C	1.346	1.753
D	0.330	0.508
F	1.194	1.346
H	0.170	0.254
I	0.050	0.254
J	5.791	6.200
M	0.400	1.270

## **IMPORTANT NOTICE**

The information presented in this document does not form part of any quotation or contract, is believed to be accurate and reliable. Canaan Semiconductor (CS) does not assume any responsibility for use of any circuitry described, no circuit patent licenses are implied. CS reserves the right to make changes to its products or to discontinue any integrated circuit product or service without notice, and advises its customers to obtain the latest version of relevant information to verify, before placing orders, that the information being relied on is current. No liability will be accepted by CS for any consequence of its use.

Customer should obtain the latest storage, soldering and handling information of products from CS before placing orders. No liability will be accepted by CS for any mis-storage, mis-soldering and mis-handling of the products, and the consequence of its use.

A few applications using integrated circuit products may involve potential risks of death, personal injury, or severe property or environmental damage. CS integrated circuit products are not designed, intended, authorized, or warranted to be suitable for use in life-support applications, devices or systems or other critical applications. Use of CS products in such applications is understood to be fully at the risk of the customer. In order to minimize risks associated with the customer's applications, the customer should provide adequate design and operating safeguards.

In no event shall CS be liable for any indirect, incidental, punitive, special or consequential damages (including - without limitation - lost profits, lost savings, business interruption, costs related to the removal or replacement of any products or rework charges) whether or not such damages are based on tort (including negligence), warranty, breach of contract or any other legal theory.

All content, text, images, data, information and other material ("Content") displayed, available or present on this document, including any trademarks or copyrights, are the property of CS or the designated owner and are protected by applicable intellectual property laws. Customer agree not to infringe upon or dilute any intellectual property of CS, as well as not to remove or modify any trademark, copyright or other proprietary notice appearing on this document. You are not allowed to reproduce, sell, publish, distribute, modify, or display this document or any Content without the prior written permission of CS.