

Description

The 9DBU0541 is a member of IDT's 1.5V Ultra-Low-Power (ULP) PCIe family. It has integrated terminations for direct connection to 100Ω transmission lines. The device has 5 output enables for clock management, and 3 selectable SMBus addresses.

Recommended Application

1.5V PCIe Gen1-2-3 Fanout Buffer (FOB)

Output Features

- 5 1–167MHz Low-Power (LP) HCSL DIF pairs with $Z_o=100\Omega$

Key Specifications

- DIF *additive* cycle-to-cycle jitter < 5ps
- DIF output-to-output skew < 60ps
- DIF *additive* phase jitter is < 300fs rms for PCIe Gen3
- DIF *additive* phase jitter < 350fs rms for SGMII

Features/Benefits

- Integrated terminations; save 20 resistors compared to standard HCSL outputs
- 35mW typical power consumption; eliminates thermal concerns
- Spread Spectrum (SS) compatible; allows SS for EMI reduction
- OE# pins; support DIF power management
- HCSL-compatible differential input; can be driven by common clock sources
- SMBus-selectable features; optimize signal integrity to application
 - slew rate for each output
 - differential output amplitude
- Device contains default configuration; SMBus interface not required for device control
- 3.3V tolerant SMBus interface works with legacy controllers
- Selectable SMBus addresses; multiple devices can easily share an SMBus segment
- 5×5 mm 32-VFQFPN; minimal board space

Block Diagram

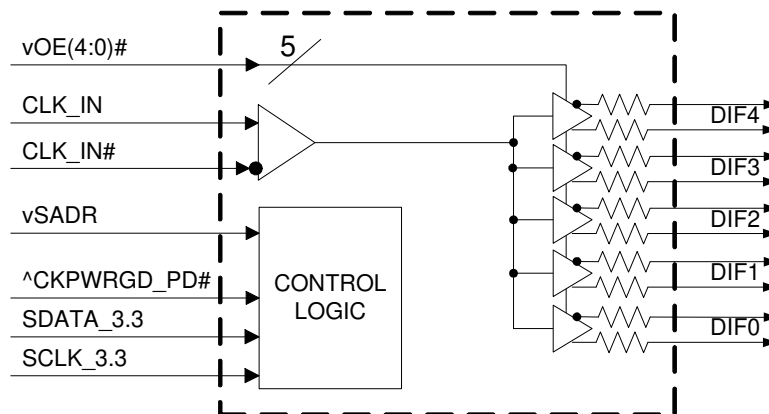

Pin Configuration

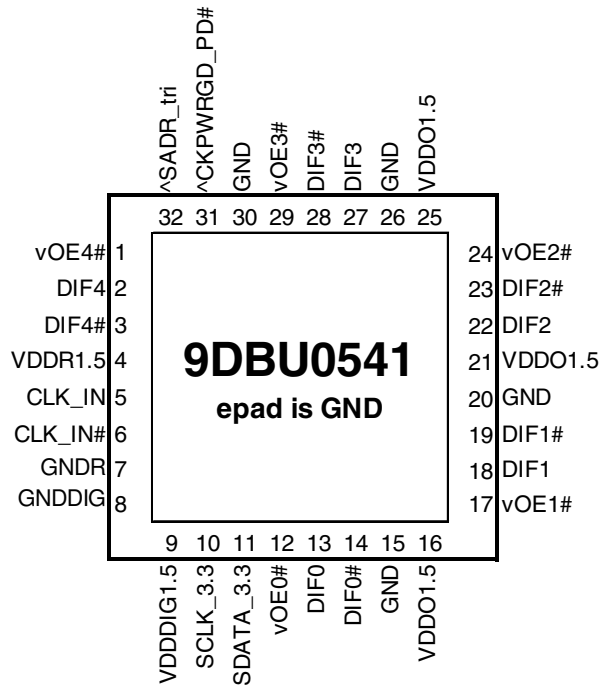

32-pin VFQFPN, 5x5 mm, 0.5mm pitch

- ^ prefix indicates internal 120KOhm pull up resistor
- ^v prefix indicates internal 120KOhm pull up AND pull down resistor (biased to VDD/2)
- v prefix indicates internal 120KOhm pull down resistor

SMBus Address Selection Table

	SADR	Address	+ Read/Write bit
State of SADR on first application of CKPWRGD_PD#	0	1101011	x
	M	1101100	x
	1	1101101	x

Power Management Table

CKPWRGD_PD#	CLK_IN	SMBus OEx bit	OEx# Pin	DIFx	
				True O/P	Comp. O/P
0	X	X	X	Low	Low
1	Running	0	X	Low	Low
1	Running	1	0	Running	Running
1	Running	1	1	Low	Low

Power Connections

Pin Number		Description
VDD	GND	
4	7	Input receiver analog
9	8	Digital power
16, 21, 25	15,20,26,30	DIF outputs

Note: EPAD on this device is not electrically connected to the die. It should be connected to ground for best thermal performance.

Pin Descriptions

Pin#	Pin Name	Type	Pin Description
1	vOE4#	IN	Active low input for enabling output 4. This pin has an internal 120kohm pull-down. 1 = disable outputs, 0 = enable outputs.
2	DIF4	OUT	Differential true clock output.
3	DIF4#	OUT	Differential complementary clock output.
4	VDDR1.5	PWR	1.5V power for differential input clock (receiver). This VDD should be treated as an Analog power rail and filtered appropriately.
5	CLK_IN	IN	True input for differential reference clock.
6	CLK_IN#	IN	Complementary input for differential reference clock.
7	GNDR	GND	Analog ground pin for the differential input (receiver)
8	GNDDIG	GND	Ground pin for digital circuitry.
9	VDDDIG1.5	PWR	1.5V digital power (dirty power)
10	SCLK_3.3	IN	Clock pin of SMBus circuitry, 3.3V tolerant.
11	SDATA_3.3	I/O	Data pin for SMBus circuitry, 3.3V tolerant.
12	vOE0#	IN	Active low input for enabling output 0. This pin has an internal 120kohm pull-down. 1 = disable outputs, 0 = enable outputs.
13	DIF0	OUT	Differential true clock output.
14	DIF0#	OUT	Differential complementary clock output.
15	GND	GND	Ground pin.
16	VDDO1.5	PWR	Power supply for outputs, nominally 1.5V.
17	vOE1#	IN	Active low input for enabling output 1. This pin has an internal 120kohm pull-down. 1 = disable outputs, 0 = enable outputs.
18	DIF1	OUT	Differential true clock output.
19	DIF1#	OUT	Differential complementary clock output.
20	GND	GND	Ground pin.
21	VDDO1.5	PWR	Power supply for outputs, nominally 1.5V.
22	DIF2	OUT	Differential true clock output.
23	DIF2#	OUT	Differential complementary clock output.
24	vOE2#	IN	Active low input for enabling output 2. This pin has an internal 120kohm pull-down. 1 = disable outputs, 0 = enable outputs.
25	VDDO1.5	PWR	Power supply for outputs, nominally 1.5V.
26	GND	GND	Ground pin.
27	DIF3	OUT	Differential true clock output.
28	DIF3#	OUT	Differential complementary clock output.
29	vOE3#	IN	Active low input for enabling output 3. This pin has an internal 120kohm pull-down. 1 = disable outputs, 0 = enable outputs.
30	GND	GND	Ground pin.
31	^CKPWRGD_PD#	IN	Input notifies device to sample latched inputs and start up on first high assertion. Low enters Power Down Mode, subsequent high assertions exit Power Down Mode. This pin has internal 120kohm pull-up resistor.
32	^SADR_tri	LATCHED IN	Tri-level latch to select SMBus Address. It has an internal 120kohm pull up resistor. See SMBus Address Selection Table.
33	EPAD	GND	Connect EPAD to ground.

Test Loads

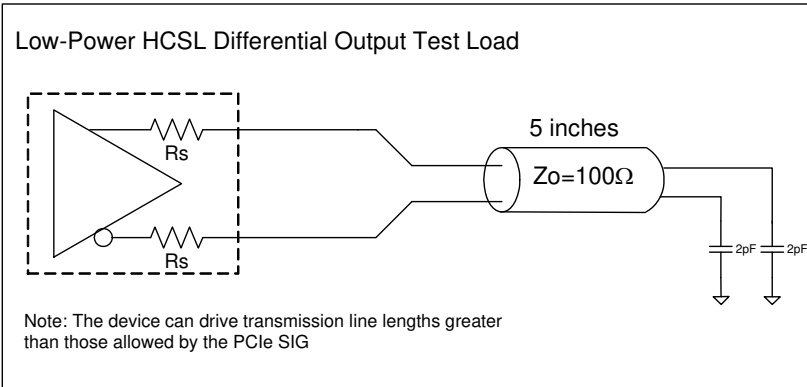

Driving LVDS

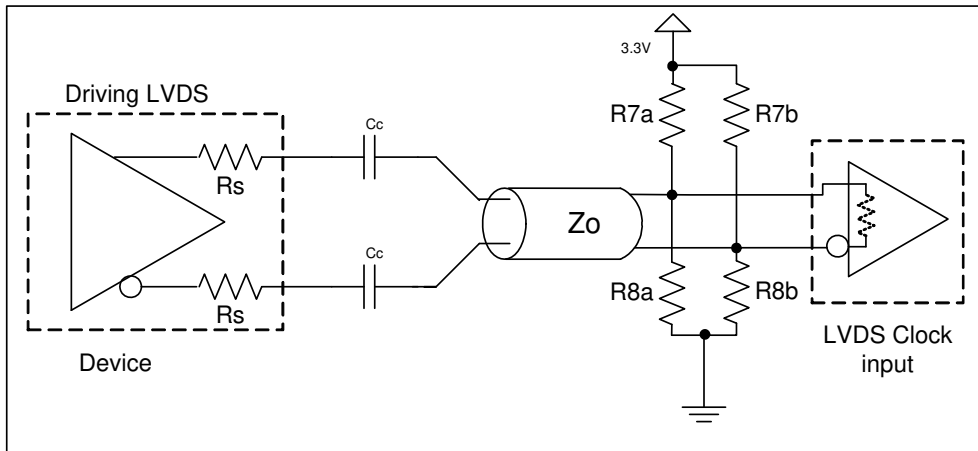

Driving LVDS Inputs

Component	Value	
	Receiver has termination	Receiver does not have termination
R7a, R7b	10K ohm	140 ohm
R8a, R8b	5.6K ohm	75 ohm
Cc	0.1μF	0.1μF
Vcm	1.2 volts	1.2 volts

Absolute Maximum Ratings

Stresses above the ratings listed below can cause permanent damage to the 9DBU0541. These ratings, which are standard values for IDT commercially rated parts, are stress ratings only. Functional operation of the device at these or any other conditions above those indicated in the operational sections of the specifications is not implied. Exposure to absolute maximum rating conditions for extended periods can affect product reliability. Electrical parameters are guaranteed only over the recommended operating temperature range.

PARAMETER	SYMBOL	CONDITIONS	MIN	TYP	MAX	UNITS	NOTES
Supply Voltage	VDDx	Applies to all VDD pins	-0.5		2	V	1,2
Input Voltage	V _{IN}		-0.5		V _{DD} +0.5	V	1,
Input High Voltage, SMBus	V _{IHSMB}	SMBus clock and data pins			3.3	V	1
Storage Temperature	T _s		-65		150	°C	1
Junction Temperature	T _j				125	°C	1
Input ESD Protection	ESD prot	Human Body Model	2000			V	1

¹Guaranteed by design and characterization, not 100% tested in production.

²Operation under these conditions is neither implied nor guaranteed.

³Not to exceed 2.0V.

Electrical Characteristics—Clock Input Parameters

T_A = T_{AMB}; Supply voltages per normal operation conditions; see Test Loads for loading conditions

PARAMETER	SYMBOL	CONDITIONS	MIN	TYP	MAX	UNITS
Input Common Mode Voltage - DIF_IN	V _{COM}	Common mode input voltage	200		725	mV
Input Swing - DIF_IN	V _{SWING}	Differential value	300		1450	mV
Input Slew Rate - DIF_IN	dv/dt	Measured differentially	0.4		8	V/ns
Input Leakage Current	I _{IN}	V _{IN} = V _{DD} , V _{IN} = GND	-5		5	uA
Input Duty Cycle	d _{tin}	Measurement from differential waveform	45	50	55	%
Input Jitter - Cycle to Cycle	J _{DIFIn}	Differential measurement	0		150	ps

¹Guaranteed by design and characterization, not 100% tested in production.

²Slew rate measured through +/-75mV window centered around differential zero.

Electrical Characteristics–Input/Supply/Common Parameters–Normal Operating Conditions

TA = T_{AMB}; Supply voltages per normal operation conditions; see Test Loads for loading conditions

PARAMETER	SYMBOL	CONDITIONS	MIN	TYP	MAX	UNITS	NOTES
Supply Voltage	VDDx	Supply voltage for core and analog	1.425	1.5	1.575	V	
Ambient Operating Temperature	T _{AMB}	Commercial range	0	25	70	°C	1
		Industrial range	-40	25	85	°C	1
Input High Voltage	V _{IH}	Single-ended inputs, except SMBus	0.75 V _{DD}		V _{DD} + 0.3	V	
Input Mid Voltage	V _{IM}	Single-ended tri-level inputs ('_tri' suffix)	0.4 V _{DD}		0.6 V _{DD}	V	
Input Low Voltage	V _{IL}	Single-ended inputs, except SMBus	-0.3		0.25 V _{DD}	V	
Input Current	I _{IN}	Single-ended inputs, V _{IN} = GND, V _{IN} = VDD	-5		5	μA	
	I _{INP}	Single-ended inputs V _{IN} = 0 V; inputs with internal pull-up resistors V _{IN} = VDD; inputs with internal pull-down resistors	-200		200	μA	
Input Frequency	F _{in}		1		167	MHz	2
Pin Inductance	L _{pin}				7	nH	1
Capacitance	C _{IN}	Logic Inputs, except DIF_IN	1.5		5	pF	1
	C _{INDIF_IN}	DIF_IN differential clock inputs	1.5		2.7	pF	1,5
	C _{OUT}	Output pin capacitance			6	pF	1
Clk Stabilization	T _{STAB}	From V _{DD} power-up and after input clock stabilization or de-assertion of PD# to 1st clock			1	ms	1,2
Input SS Modulation Frequency PCIe	f _{MODINPCIe}	Allowable frequency for PCIe applications (Triangular modulation)	30		33	kHz	
Input SS Modulation Frequency non-Pcie	f _{MODIN}	Allowable frequency for non-Pcie applications (Triangular modulation)	0		66	kHz	
OE# Latency	t _{LATOE#}	DIF start after OE# assertion DIF stop after OE# deassertion	1		3	clocks	1,3
Tdrive_PD#	t _{DRVPD}	DIF output enable after PD# de-assertion			300	μs	1,3
Tfall	t _F	Fall time of single-ended control inputs			5	ns	2
Trise	t _R	Rise time of single-ended control inputs			5	ns	2
SMBus Input Low Voltage	V _{ILSMB}				0.6	V	
SMBus Input High Voltage	V _{IHSMB}	V _{DD} SMB = 3.3V, see note 4 for V _{DD} SMB < 3.3V	2.1		3.3	V	4
SMBus Output Low Voltage	V _{OLSMB}	at I _{PULLUP}			0.4	V	
SMBus Sink Current	I _{PULLUP}	at V _{OL}	4			mA	
Nominal Bus Voltage	V _{DD} SMB	Bus voltage	1.425		3.3	V	
SCLK/SDATA Rise Time	t _{RSMB}	(Max V _{IL} - 0.15V) to (Min V _{IH} + 0.15V)			1000	ns	1
SCLK/SDATA Fall Time	t _{FSMB}	(Min V _{IH} + 0.15V) to (Max V _{IL} - 0.15V)			300	ns	1
SMBus Operating Frequency	f _{MAXSMB}	Maximum SMBus operating frequency			400	kHz	6

¹ Guaranteed by design and characterization, not 100% tested in production.

² Control input must be monotonic from 20% to 80% of input swing.

³ Time from deassertion until outputs are > 200 mV.

⁴ For V_{DD}SMB < 3.3V, V_{IHSMB} >= 0.8xV_{DD}SMB

⁵ DIF_IN input.

⁶ The differential input clock must be running for the SMBus to be active.

Electrical Characteristics–DIF Low-Power HCSL Outputs

TA = T_{AMB}; Supply voltages per normal operation conditions; see Test Loads for loading conditions

PARAMETER	SYMBOL	CONDITIONS	MIN	TYP	MAX	UNITS	NOTES
Slew Rate	dV/dt	Scope averaging on, fast setting	1	2.4	3.5	V/ns	1,2,3
	dV/dt	Scope averaging on, slow setting	0.7	1.7	2.5	V/ns	1,2,3
Slew Rate Matching	Δ dV/dt	Slew rate matching, scope averaging on		9	20	%	1,2,4
Voltage High	V _{HIGH}	Statistical measurement on single-ended signal using oscilloscope math function. (Scope averaging on)	630	750	850	mV	7
Voltage Low	V _{LOW}		-150	26	150		7
Max Voltage	V _{max}	Measurement on single ended signal using absolute value. (Scope averaging off)		763	1150	mV	7
Min Voltage	V _{min}		-300	22			7
Vswing	Vswing	Scope averaging off	300	1448		mV	1,2
Crossing Voltage (abs)	V _{cross_abs}	Scope averaging off	250	390	550	mV	1,5
Crossing Voltage (var)	Δ -V _{cross}	Scope averaging off		11	140	mV	1,6

¹Guaranteed by design and characterization, not 100% tested in production.

² Measured from differential waveform.

³ Slew rate is measured through the Vswing voltage range centered around differential 0V. This results in a +/-150mV window around differential 0V.

⁴ Matching applies to rising edge rate for Clock and falling edge rate for Clock#. It is measured using a +/-75mV window centered on the average cross point where Clock rising meets Clock# falling. The median cross point is used to calculate the voltage thresholds the oscilloscope is to use for the edge rate calculations.

⁵ V_{cross} is defined as voltage where Clock = Clock# measured on a component test board and only applies to the differential rising edge (i.e. Clock rising and Clock# falling).

⁶ The total variation of all V_{cross} measurements in any particular system. Note that this is a subset of V_{cross_min/max} (V_{cross} absolute) allowed. The intent is to limit V_{cross} induced modulation by setting Δ -V_{cross} to be smaller than V_{cross} absolute.

⁷ At default SMBus settings.

Electrical Characteristics–Current Consumption

TA = T_{AMB}; Supply voltages per normal operation conditions; see Test Loads for loading conditions

PARAMETER	SYMBOL	CONDITIONS	MIN	TYP	MAX	UNITS	NOTES
Operating Supply Current	I _{DDR}	VDDR at 100MHz		1.9	3	mA	
	I _{DDDIG}	VDDIG, all outputs at 100MHz		0.1	0.5	mA	
	I _{DDAO}	VDDO1.5+VDDO, all outputs at 100MHz		20	25	mA	
Powerdown Current	I _{DDRPD}	VDDR, CKPWRGD_PD# = 0		0.001	0.3	mA	2
	I _{DDDIGPD}	VDDDIG, CKPWRGD_PD# = 0		0.1	0.2	mA	2
	I _{DDAOPD}	VDDO1.5+VDDO, CKPWRGD_PD# = 0		0.5	1	mA	2

¹ Guaranteed by design and characterization, not 100% tested in production.

² Input clock stopped.

Electrical Characteristics–Output Duty Cycle, Jitter, Skew and PLL Characteristics

TA = T_{AMB}; Supply voltages per normal operation conditions; see Test Loads for loading conditions

PARAMETER	SYMBOL	CONDITIONS	MIN	TYP	MAX	UNITS	NOTES
Duty Cycle Distortion	t _{DCD}	Measured differentially, at 100MHz	-1	-0.2	0.5	%	1,3
Skew, Input to Output	t _{pdBYP}	V _T = 50%	2400	2862	3700	ps	1
Skew, Output to Output	t _{sk3}	V _T = 50%		30	50	ps	1,4
Jitter, Cycle to Cycle	t _{jcy-cyc}	Additive Jitter		0.1	5	ps	1,2

¹ Guaranteed by design and characterization, not 100% tested in production.

² Measured from differential waveform.

³ Duty cycle distortion is the difference in duty cycle between the output and the input clock.

⁴ All outputs at default slew rate.

Electrical Characteristics–Phase Jitter Parameters

TA = T_{AMB}; Supply voltages per normal operation conditions; see Test Loads for loading conditions

PARAMETER	SYMBOL	CONDITIONS	MIN	TYP	MAX	INDUSTRY LIMIT	UNITS	Notes
Additive Phase Jitter	t _{jphPCleG1}	PCle Gen 1		0.1	5	N/A	ps (p-p)	1,2,3,5
	t _{jphPCleG2}	PCle Gen 2 Lo Band 10kHz < f < 1.5MHz		0.1	0.4	N/A	ps (rms)	1,2,3,4,5
		PCle Gen 2 High Band 1.5MHz < f < Nyquist (50MHz)		0.1	0.7	N/A	ps (rms)	1,2,3,4
	t _{jphPCleG3}	PCle Gen 3 (2-4MHz or 2-5MHz, CDR = 10MHz)		0.1	0.3	N/A	ps (rms)	1,2,3,4
	t _{jphSGMIIM0}	125MHz, 1.5MHz to 10MHz, -20dB/decade rollover < 1.5MHz, -40db/decade rolloff > 10MHz		200	250	N/A	fs (rms)	1,6
	t _{jphSGMIIM1}	125MHz, 12kHz to 20MHz, -20dB/decade rollover < 1.5MHz, -40db/decade rolloff > 10MHz		313	350	N/A	fs (rms)	1,6

¹ Guaranteed by design and characterization, not 100% tested in production.

² See <http://www.pcisig.com> for complete specs.

³ Sample size of at least 100K cycles. This figure extrapolates to 108ps pk-pk at 1M cycles for a BER of 1-12.

⁴ For RMS figures, additive jitter is calculated by solving the following equation: Additive jitter = SQRT[(total jitter)² - (input jitter)²].

⁵ Driven by 9FGV0831 or equivalent.

⁶ Rohde & Schwarz SMA100.

Additive Phase Jitter Plot: 125M (12kHz to 20MHz)

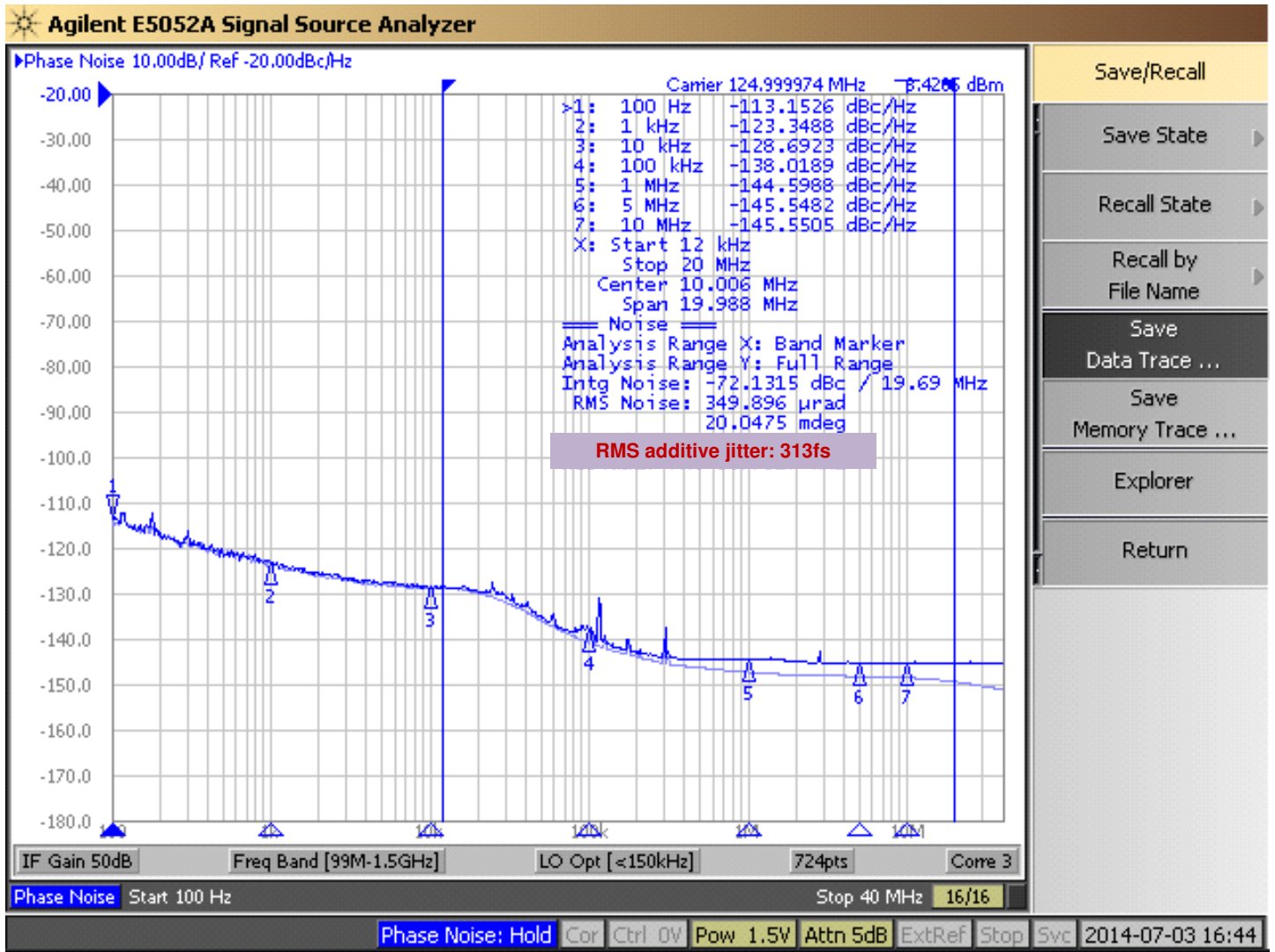

General SMBus Serial Interface Information

How to Write

- Controller (host) sends a start bit
- Controller (host) sends the write address
- IDT clock will **acknowledge**
- Controller (host) sends the beginning byte location = N
- IDT clock will **acknowledge**
- Controller (host) sends the byte count = X
- IDT clock will **acknowledge**
- Controller (host) starts sending Byte **N through Byte N+X-1**
- IDT clock will **acknowledge** each byte **one at a time**
- Controller (host) sends a stop bit

Index Block Write Operation			
Controller (Host)			IDT (Slave/Receiver)
T	starT bit		
Slave Address			
WR	WRite		
			ACK
Beginning Byte = N			
			ACK
Data Byte Count = X			
			ACK
Beginning Byte N		X Byte	
			ACK
O			O
O			O
O			O
Byte N + X - 1			
			ACK
P	stoP bit		

How to Read

- Controller (host) will send a start bit
- Controller (host) sends the write address
- IDT clock will **acknowledge**
- Controller (host) sends the beginning byte location = N
- IDT clock will **acknowledge**
- Controller (host) will send a separate start bit
- Controller (host) sends the read address
- IDT clock will **acknowledge**
- IDT clock will send the data byte count = X
- IDT clock sends Byte **N+X-1**
- IDT clock sends **Byte 0 through Byte X (if X_(H) was written to Byte 8)**
- Controller (host) will need to acknowledge each byte
- Controller (host) will send a not acknowledge bit
- Controller (host) will send a stop bit

Index Block Read Operation			
Controller (Host)			IDT (Slave/Receiver)
T	starT bit		
Slave Address			
WR	WRite		
			ACK
Beginning Byte = N			
			ACK
RT	Repeat starT		
Slave Address			
RD	ReaD		
			ACK
			Data Byte Count=X
ACK		X Byte	Beginning Byte N
ACK			
O			O
O			O
O			O
			Byte N + X - 1
N	Not acknowledge		
P	stoP bit		

Note: SMBus Address is Latched on SADR pin.

SMBus Table: Output Enable Register ¹

Byte 0	Name	Control Function	Type	0	1	Default
Bit 7	Reserved					1
Bit 6	DIF OE3	Output Enable	RW	Low/Low	Enabled	1
Bit 5	DIF OE2	Output Enable	RW	Low/Low	Enabled	1
Bit 4	Reserved					1
Bit 3	DIF OE1	Output Enable	RW	Low/Low	Enabled	1
Bit 2	Reserved					1
Bit 1	DIF OE0	Output Enable	RW	Low/Low	Enabled	1
Bit 0	Reserved					1

1. A low on these bits will override the OE# pin and force the differential output Low/Low

SMBus Table: PLL Operating Mode and Output Amplitude Control Register

Byte 1	Name	Control Function	Type	0	1	Default
Bit 7	Reserved					0
Bit 6	Reserved					1
Bit 5	DIF OE4	Output Enable	RW	Low/Low	Enabled	1
Bit 4	Reserved					0
Bit 3	Reserved					1
Bit 2	Reserved					1
Bit 1	AMPLITUDE 1	Controls Output Amplitude	RW	00 = 0.55V	01 = 0.65V	1
Bit 0	AMPLITUDE 0		RW	10 = 0.7V	11 = 0.8V	0

1. A low on the DIF OE bit will override the OE# pin and force the differential output Low/Low

SMBus Table: DIF Slew Rate Control Register

Byte 2	Name	Control Function	Type	0	1	Default
Bit 7	Reserved					1
Bit 6	SLEWRATESEL DIF3	Slew Rate Selection	RW	Slow Setting	Fast Setting	1
Bit 5	SLEWRATESEL DIF2	Slew Rate Selection	RW	Slow Setting	Fast Setting	1
Bit 4	Reserved					1
Bit 3	SLEWRATESEL DIF1	Slew Rate Selection	RW	Slow Setting	Fast Setting	1
Bit 2	Reserved					1
Bit 1	Slow Setting	Fast Setting	RW	Slow Setting	Fast Setting	1
Bit 0	Reserved					1

Note: See "DIF 0.7V Low-Power HCSL Outputs" table for slew rates.

SMBus Table: DIF Slew Rate Control Register

Byte 3	Name	Control Function	Type	0	1	Default
Bit 7	Reserved					1
Bit 6	Reserved					1
Bit 5	Reserved					0
Bit 4	Reserved					0
Bit 3	Reserved					0
Bit 2	Reserved					1
Bit 1	Reserved					1
Bit 0	SLEWRATESEL DIF4	Adjust Slew Rate of DIF4	RW	Slow Setting	Fast Setting	1

Note: See "DIF 0.7V Low-Power HCSL Outputs" table for slew rates.

Byte 4 is Reserved and reads back 'hFF'

SMBus Table: Revision and Vendor ID Register

Byte 5	Name	Control Function	Type	0	1	Default
Bit 7	RID3	Revision ID	R	A rev = 0000		0
Bit 6	RID2		R			0
Bit 5	RID1		R			0
Bit 4	RID0		R			0
Bit 3	VID3	VENDOR ID	R	0001 = IDT/ICS		0
Bit 2	VID2		R			0
Bit 1	VID1		R			0
Bit 0	VID0		R			1

SMBus Table: Device Type/Device ID

Byte 6	Name	Control Function	Type	0	1	Default
Bit 7	Device Type1	Device Type	R	00 = FGx, 01 = DBx, 10 = DMx, 11= DBx w/oPLL		1
Bit 6	Device Type0		R			1
Bit 5	Device ID5	Device ID	R	000101 binary or 05 hex		0
Bit 4	Device ID4		R			0
Bit 3	Device ID3		R			0
Bit 2	Device ID2		R			1
Bit 1	Device ID1		R			0
Bit 0	Device ID0		R			1

SMBus Table: Byte Count Register

Byte 7	Name	Control Function	Type	0	1	Default
Bit 7		Reserved				0
Bit 6		Reserved				0
Bit 5		Reserved				0
Bit 4	BC4	Byte Count Programming	RW	Writing to this register will configure how many bytes will be read back, default is = 8 bytes.		0
Bit 3	BC3		RW			1
Bit 2	BC2		RW			0
Bit 1	BC1		RW			0
Bit 0	BC0		RW			0

Marking Diagrams

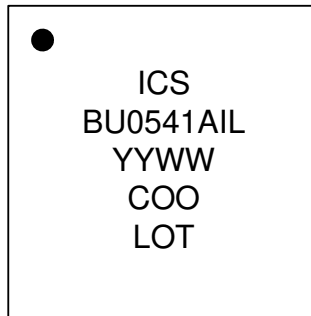
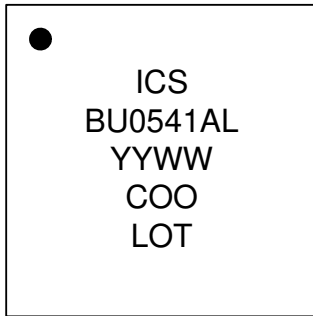

Notes:

1. "LOT" is the lot sequence number.
2. "COO" denotes country of origin.
3. YYWW is the last two digits of the year and week that the part was assembled.
4. Line 2: truncated part number
5. "L" denotes RoHS compliant package.
6. "I" denotes industrial temperature range device.

Thermal Characteristics

PARAMETER	SYMBOL	CONDITIONS	PKG	TYP VALUE	UNITS	NOTES
Thermal Resistance	θ_{JC}	Junction to Case	NLG32	42	°C/W	1
	θ_{Jb}	Junction to Base		2.4	°C/W	1
	θ_{JA0}	Junction to Air, still air		39	°C/W	1
	θ_{JA1}	Junction to Air, 1 m/s air flow		33	°C/W	1
	θ_{JA3}	Junction to Air, 3 m/s air flow		28	°C/W	1
	θ_{JA5}	Junction to Air, 5 m/s air flow		27	°C/W	1

¹ePad soldered to board

Package Outline and Dimensions (NLG32)

REVISIONS			
REV	DESCRIPTION	DATE	APPROVED
00	INITIAL RELEASE	11/23/15	J.H
01	MODIFY DIMENSION TABLE	11/30/15	J.H

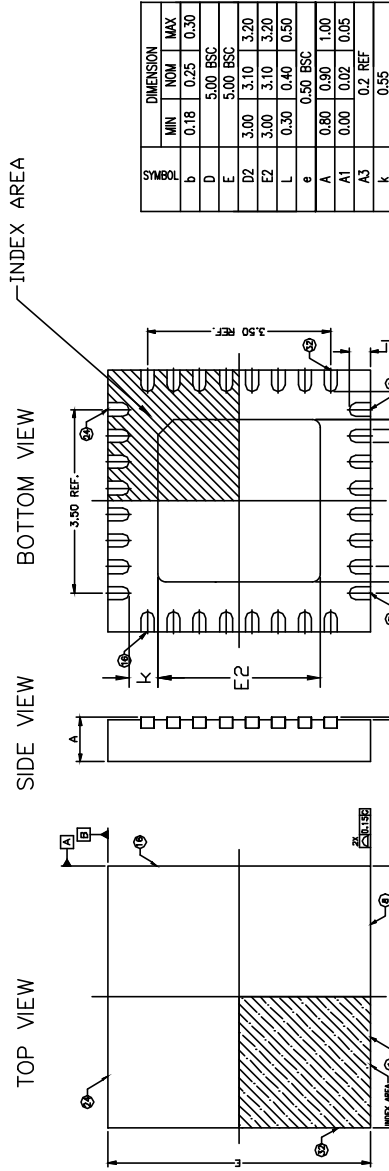

NOTE :

1. ALL DIMENSIONS ARE IN mm, ANGLES IN DEGREES.
2. CIRCULARITY APPLIES TO THE EXPOSED PAD AS WELL AS THE TERMINALS.
3. WARRPAGE SHALL NOT EXCEED 0.98 mm.

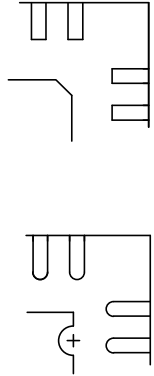

		6024 Silver Creek Valley Rd San Jose, CA 95138 PHONE: (408) 284-8200 FAX: (408) 284-3572	
TOLERANCES UNLESS SPECIFIED DECIMAL ±.1 XX± .05 XXX± .030	WWW.IDT.COM	TITLE NL/NLG 32 PACKAGE OUTLINE 5.0 x 5.0 mm BODY, EPAD 3.10 mm SQ 0.50 mm PITCH QFN.	REV 01
APPROVALS DRAWN @JAC CHECKED	DATE 11/23/15	SIZE C DRAWING No. PSC-4171-03	DO NOT SCALE DRAWING SHEET 1 OF 2

Package Outline and Dimensions (NLG32), cont.

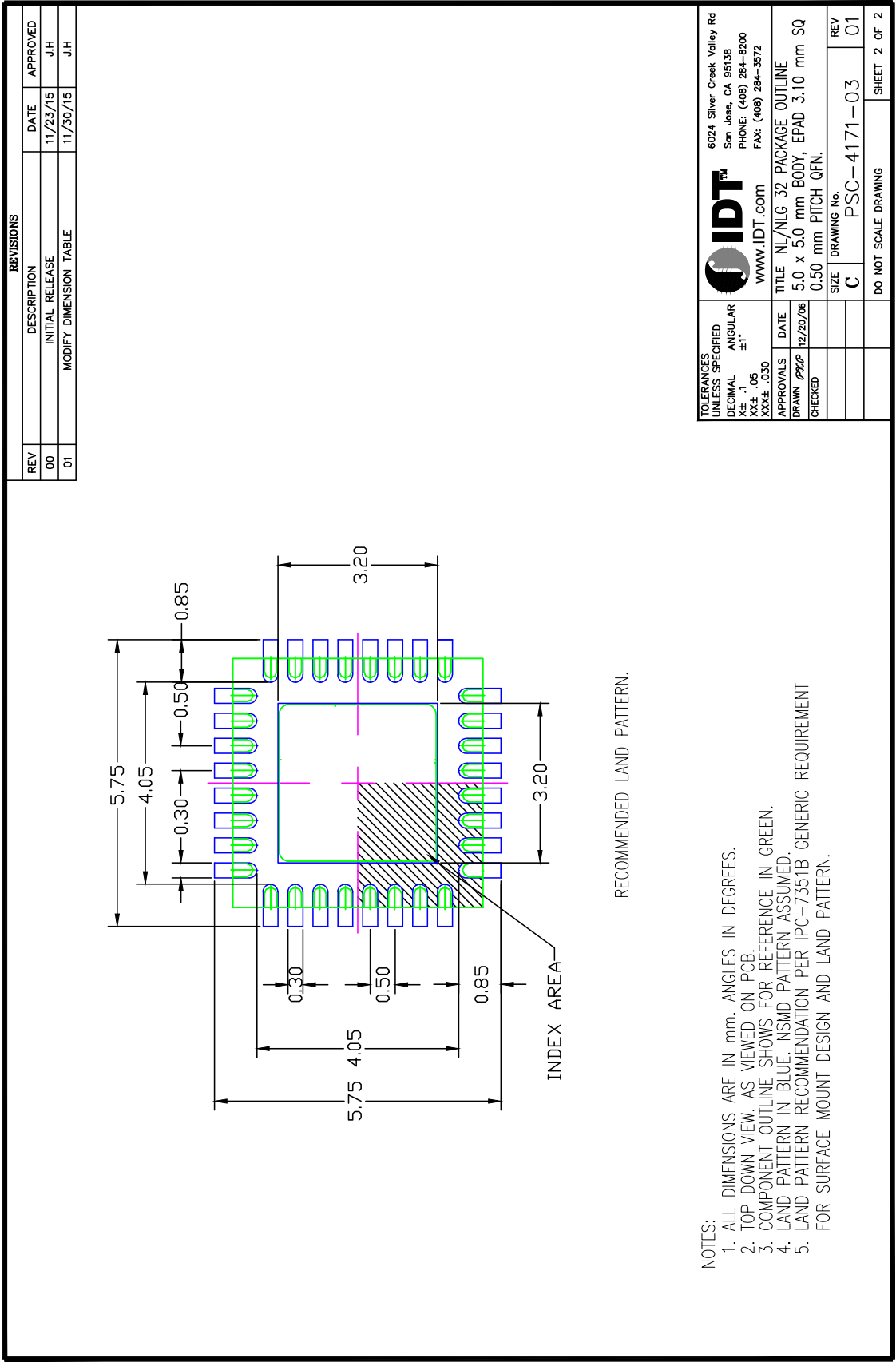

<p>TOLERANCES UNLESS SPECIFIED</p> <p>DECIMAL ANGULAR XX± .05 ±1° XXX± .030</p> <p>APPROVALS DATE DRAWN PXP/12/20/06 CHECKED</p>	<p>6024 Silver Creek Valley Rd San Jose, CA 95138 PHONE: (408) 284-8200 FAX: (408) 284-3572</p> <p>www.IDT.com</p>	<p>TITLE NL/NLG 32 PACKAGE OUTLINE 5.0 x 5.0 mm BODY, EPAD 3.10 mm SQ 0.50 mm PITCH QFN.</p> <p>SIZE DRAWING No. PSC-4171-03 REV 01</p> <p>DO NOT SCALE DRAWING SHEET 2 OF 2</p>
---	--	--

Ordering Information

Part / Order Number	Shipping Packaging	Package	Temperature
9DBU0541AKLFF	Trays	32-pin VFQFPN	0 to +70° C
9DBU0541AKLFT	Tape and Reel	32-pin VFQFPN	0 to +70° C
9DBU0541AKILF	Trays	32-pin VFQFPN	-40 to +85° C
9DBU0541AKILFT	Tape and Reel	32-pin VFQFPN	-40 to +85° C

“LF” suffix to the part number are the Pb-Free configuration and are RoHS compliant.

“A” is the device revision designator (will not correlate with the datasheet revision).

Revision History

Rev.	Initiator	Issue Date	Description	Page #
A	RDW	7/15/2014	Final update and release - front page and electrical tables.	Various
B	RDW	7/24/2014	1. Removed VDDIO reference in the Electrical Characteristics - Input/Supply/Common Parameters and Absolute Maximum Ratings tables. This power rail does not exist on this device. The pinout and the pin descriptions are correct.	6
C	RDW	9/19/2014	Updated SMBus Input High/Low parameters conditions, MAX values, and footnotes.	6
D	RDW	4/22/2015	1. Updated Key Specifications to be consistent across the family. 2. Updated pin out and pin descriptions to show ePad on package connected to ground. 3. Updated Clock Input Parameters table to be consistent with PCIe Vswing parameter. 4. Add note about epad to Power Connections table.	1-3,5
E	RDW	2/16/2017	1. Updated pins 21 and 20 from VDDA1.5/GNDA to VDDO1.5/GND to clearly indicate that this part has no PLL.	2, 3
F	RDW	3/9/2017	1. Removed "Bypass Mode" reference in "Output Duty Cycle..." and "Phase Jitter Parameters" tables; update note 3 under Output Duty Cycle table. 2. Corrected spelling errors/typos. 3. Change VDDA to VDDO1.5 in Current Consumption table. 4. Update Additive Phase Jitter conditions for PCIe Gen3.	7, 8

IMPORTANT NOTICE AND DISCLAIMER

RENESAS ELECTRONICS CORPORATION AND ITS SUBSIDIARIES (“RENESAS”) PROVIDES TECHNICAL SPECIFICATIONS AND RELIABILITY DATA (INCLUDING DATASHEETS), DESIGN RESOURCES (INCLUDING REFERENCE DESIGNS), APPLICATION OR OTHER DESIGN ADVICE, WEB TOOLS, SAFETY INFORMATION, AND OTHER RESOURCES “AS IS” AND WITH ALL FAULTS, AND DISCLAIMS ALL WARRANTIES, EXPRESS OR IMPLIED, INCLUDING, WITHOUT LIMITATION, ANY IMPLIED WARRANTIES OF MERCHANTABILITY, FITNESS FOR A PARTICULAR PURPOSE, OR NON-INFRINGEMENT OF THIRD PARTY INTELLECTUAL PROPERTY RIGHTS.

These resources are intended for developers skilled in the art designing with Renesas products. You are solely responsible for (1) selecting the appropriate products for your application, (2) designing, validating, and testing your application, and (3) ensuring your application meets applicable standards, and any other safety, security, or other requirements. These resources are subject to change without notice. Renesas grants you permission to use these resources only for development of an application that uses Renesas products. Other reproduction or use of these resources is strictly prohibited. No license is granted to any other Renesas intellectual property or to any third party intellectual property. Renesas disclaims responsibility for, and you will fully indemnify Renesas and its representatives against, any claims, damages, costs, losses, or liabilities arising out of your use of these resources. Renesas' products are provided only subject to Renesas' Terms and Conditions of Sale or other applicable terms agreed to in writing. No use of any Renesas resources expands or otherwise alters any applicable warranties or warranty disclaimers for these products.

(Disclaimer Rev.1.0 Mar 2020)

Corporate Headquarters

TOYOSU FORESIA, 3-2-24 Toyosu,
Koto-ku, Tokyo 135-0061, Japan
www.renesas.com

Contact Information

For further information on a product, technology, the most up-to-date version of a document, or your nearest sales office, please visit:
www.renesas.com/contact/

Trademarks

Renesas and the Renesas logo are trademarks of Renesas Electronics Corporation. All trademarks and registered trademarks are the property of their respective owners.