

THIS DRAWING IS UNPUBLISHED. RELEASED FOR PUBLICATION
 © COPYRIGHT - TE Connectivity ALL RIGHTS RESERVED.

REVISIONS				
P	LTR	DESCRIPTION	DATE	APVD
G3		REMOVING FASR NOTE FROM -2	11JUN2019	SV PKS

- 1 CONTINUOUS STRIP ON REELS WITH TERMINALS LOCATED ON 8.38±0.08 [.003±.003] CENTERS.
- △2 SLOT ACCEPTS 0.91-1.15mm [#19-#17] AWG COPPER MAGNET WIRE. ONE WIRE MAX PER SLOT
- △3 IDENTIFICATION NUMBER 24 FOR THE MAGNET WIRE SLOT SIZE
- △4 0.25[.010] MAX CARRIER CUT-OFF TABS.

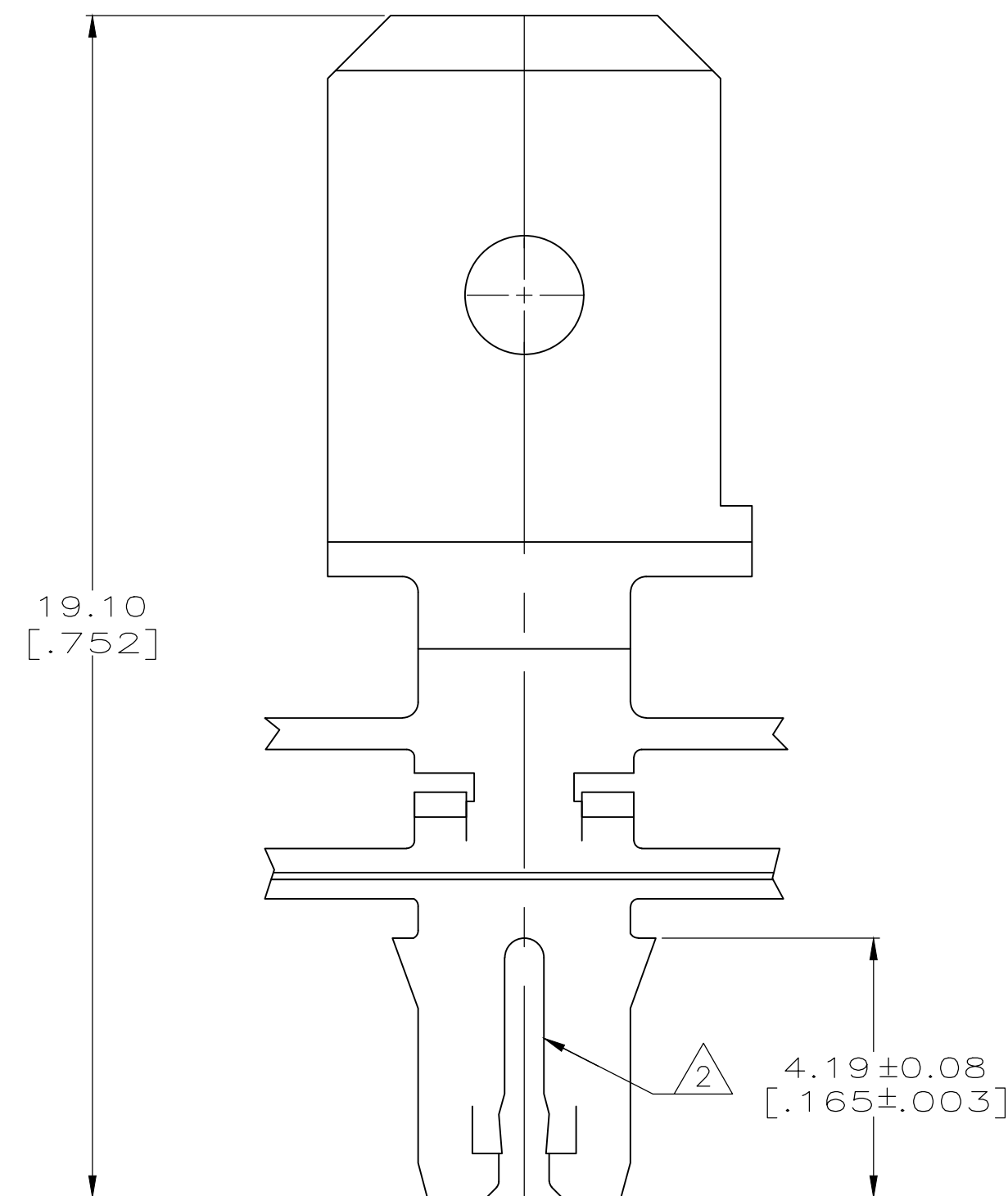
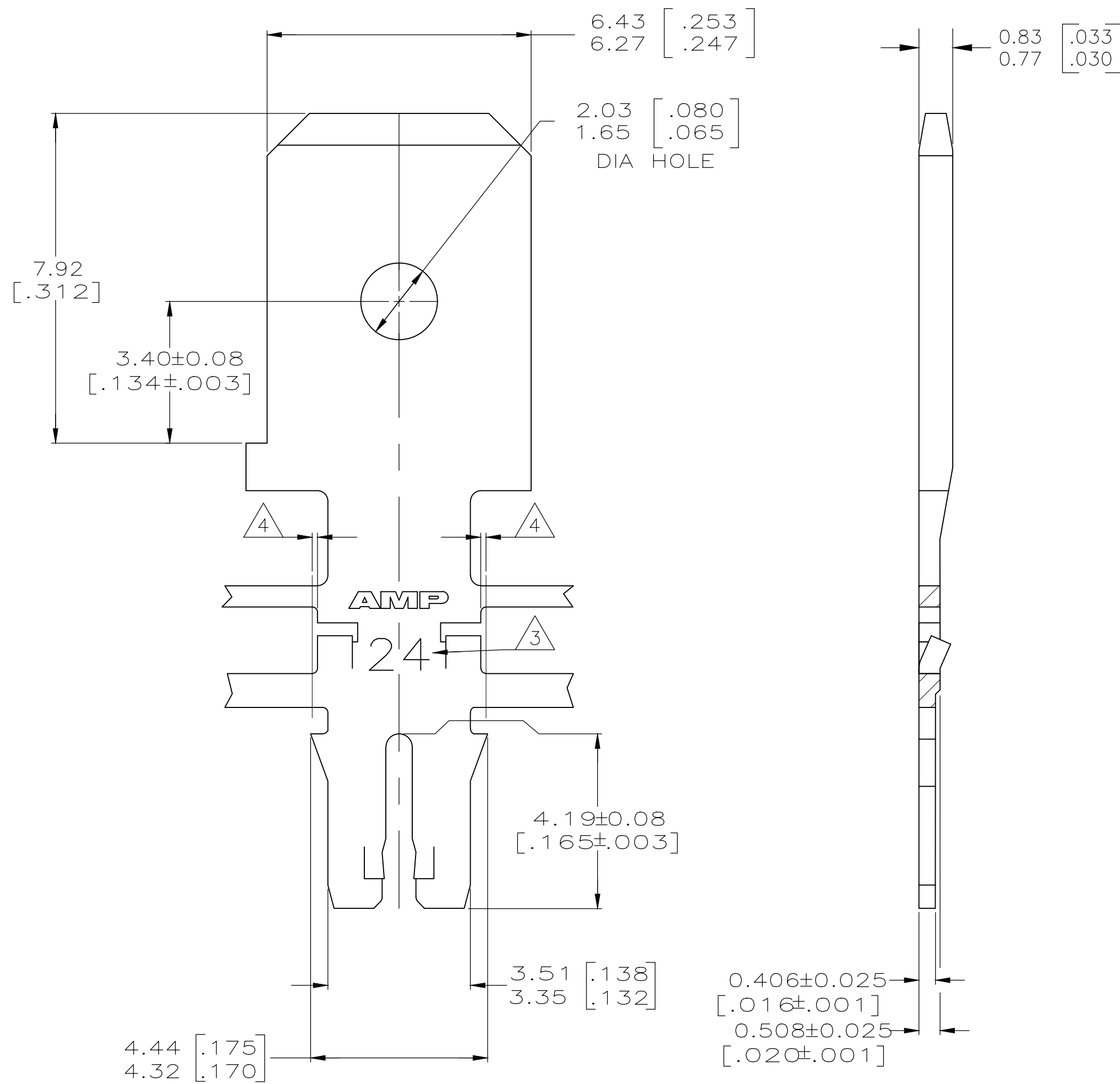

082 PRE-MILLED BRASS	63720-2
4M PRE-MILLED BRASS	63720-1
MATERIAL	PART NUMBER

THIS DRAWING IS A CONTROLLED DOCUMENT.		DWN 9-27-93 L.A.MAYER	TE TE Connectivity		
DIMENSIONS: INCHES		CHK 9-27-93 M.S. FEHER			
TOLERANCES UNLESS OTHERWISE SPECIFIED:		APVD 9-27-93 A. HUNT III	NAME TAB, 6.35 [.250] FASTON™ MAG-MATE™ Slim Line		
0 PLC ± -		PRODUCT SPEC 108-1484	SIZE A2	CAGE CODE 00779	DRAWING NO C-63720
1 PLC ± -		APPLICATION SPEC 114-2140	WEIGHT 0	SCALE 10:1	SHEET 1 of 1
2 PLC ± 0.13 [.005]		FINISH 0.002032 [.000080] MIN TIN PLATE	CUSTOMER DRAWING	REV G3	RESTRICTED TO -
3 PLC ± -					
4 PLC ± -					
ANGLES ± -					
MATERIAL SEE TABLE					