

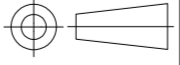

THIS DRAWING IS UNPUBLISHED.      RELEASED FOR PUBLICATION  
 © COPYRIGHT - By -      ALL RIGHTS RESERVED.

LOC	DIST	REVISIONS					
AD	38	P	LTR	DESCRIPTION	DATE	DWN	APVD
		-		SEE SHEET 1	-	-	-

FINISH	E	D	C	B	A	NO OF POS	ASSEMBLY PART NUMBER
△4	.125	.318	3.984	3.900	39	40	9- 87348 -0
			3.884	3.800	38	39	8- ↑ -9
			3.784	3.700	37	38	8- -8
			3.684	3.600	36	37	8- -7
			3.584	3.500	35	36	8- -6
			3.484	3.400	34	35	8- -5
			3.384	3.300	33	34	8- -4
			3.284	3.200	32	33	8- -3
			3.184	3.100	31	32	8- -2
			3.840	3.000	30	31	8- -1
			2.984	2.900	29	30	8- -0
			2.884	2.800	28	29	7- -9
			2.784	2.700	27	28	7- -8
			2.684	2.600	26	27	7- -7
			2.584	2.500	25	26	7- -6
			2.484	2.400	24	25	7- -5
			2.384	2.300	23	24	7- -4
			2.284	2.200	22	23	7- -3
			2.184	2.100	21	22	7- -2
			2.084	2.000	20	21	7- -1
			1.984	1.900	19	20	7- -0
			1.884	1.800	18	19	6- -9
			1.784	1.700	17	18	6- -8
			1.684	1.600	16	17	6- -7
			1.584	1.500	15	16	6- -6
			1.484	1.400	14	15	6- -5
			1.384	1.300	13	14	6- -4
			1.284	1.200	12	13	6- -3
			1.184	1.100	11	12	6- -2
			1.840	1.000	10	11	6- -1
			.984	.900	9	10	6- -0
			.884	.800	8	9	5- -9
			.784	.700	7	8	5- -8
			.684	.600	6	7	5- -7
			.584	.500	5	6	5- -6
			.484	.400	4	5	5- -5
			.384	.300	3	4	5- -4
			.284	.200	2	3	5- -3
			.184	.100	1	2	5- ↓ -2
△4	.125	.318	.084	0	0	1	5- 87348 -1

THIS DRAWING IS A CONTROLLED DOCUMENT.		DWN K HELM 6-89	 TE Connectivity			
DIMENSIONS: INCHES		CHK R. FEIDT 6-89				
TOLERANCES UNLESS OTHERWISE SPECIFIED:		APVD R. FEIDT 6-89	NAME ASSEMBLY, MOD II, HEADER, SINGLE ROW, .100 C/L, VERTICAL, .025 SQ POSTS			
 0 PLC ± - 1 PLC ± - 2 PLC ± - 3 PLC ± .005 4 PLC ± - ANGLES ± -		PRODUCT SPEC -	SIZE A2	CAGE CODE 00779	DRAWING NO C=87348	RESTRICTED TO -
MATERIAL -		FINISH SEE TABLE	WEIGHT -	SCALE 4:1	SHEET 2 of 2	REV L
CUSTOMER DRAWING						