

# IXIDM1401 - HIGH VOLTAGE ISOLATED DRIVER MODULE

FEBRUARY 2017

## OVERVIEW

The new IXIDM1401 driver module combines supreme compactness with the highest performance and reliability. It comprises a dual-channel driver core that targets medium power dual-channel IGBTs for up to 4kV and applications such as inverters, drives & automation, UPS, renewable energy, transportation and medical. Its parallel capability allows easy high power system design. It supports switching up to 250 kHz, short-circuit protection, advanced active clamping and supply-voltage monitoring.

Built using the IX6610/11 gate-driver chipset, it allows a 3.3 V microcontroller (MCU), through a 4 kV isolation barrier, to control IGBTs in the half-bridge configuration; the PWM signals can be as short as 500 ns, and there is no lower limit on the switching frequency.

An internal power supply can provide up to 2W per channel of isolated power to drive both upper and lower IGBTs, effectively isolating the MCU from the high power circuitry. Operating from a single polarity 15V power source, it provides +15 V/-5V to the IGBT gates as well as +3.3V (at 50mA) to the MCU.

A built-in under-voltage and over-voltage protection prevents the IGBTs from operating at gate voltages outside of the optimal window and informs the MCU about such conditions without regard to the source of the problems, which may come from either the low/high side IGBT behind the isolation barrier or the primary side before the isolation barrier.

An over-current protection with a 300 mV threshold can be implemented by utilizing either a current-sense resistor or IGBT de-saturation event. It turns the IGBT off

immediately after the collector current exceeds a value set by the user and informs the MCU to make an appropriate decision. An Active Clamping Comparator with a 3.1 V threshold (with respect to the negative IGBT gate voltage) disables the driver when the collector voltage exceeds a level set by the user, preventing excessive power dissipation in the IGBTs.

The built-in dead time delay circuitry, with channel A priority, prevents the IGBTs from turning on simultaneously. If channel B is active and channel A is forced into on-state, channel B becomes disabled immediately and channel A IGBT turns on with a preset delay time. After channel A becomes inactive, channel B, if active, turns on with the same delay time. If channel A is active and channel B is forced into on-state, this command will be ignored as long as channel A remains active. If channel A becomes inactive before the command activating channel B expires, channel B becomes active with a preset delay time after channel A becomes inactive.

The over-temperature protection function disables the IGBTs if the internal chip's temperature exceeds 150°C and resumes normal operations when the temperature falls below 125°C. If the IGBT assembly is equipped with a temperature sensor, the IXIDM1401 is able to translate its signal for the MCU.

The IXIDM1401 is available in a 50x50x25 mm package with a 12-pin, 1 mm-pitch FFC connector to communicate with an MCU, two 5-pin, 2.54 mm-pitch headers to provide signals to/from the IGBTs, and one 2 pin, 2.54 mm-pitch header to translate signals from a temperature sensor of the IGBTs.



## APPLICATIONS

- Various Appliances with Motors Operating by Microcontrollers
- Wind power and photovoltaic
- Industrial drives
- Electric/hybrid drive commercial vehicles
- Uninterruptible power supplies (UPS)
- Driving large parallel-connected IGBTs
- Medical (MrT, CT, X-ray)
- Tractions Applications

## KEY FEATURES

- Dual Channel Driver for Half-Bridge Switching Modules
- Blocking voltages up to 4000 V
- Minimum Input Pulse Width 500 ns
- Input to Output Gate Driver Signal Propagation Delay <100 ns
- Gate Drive Pulse Width Distortion <20 ns
- Internal Power Supply for Isolated Drivers with up to 2 W Output Power per Channel
- +15 V/-5 V Isolated Gate Driver Output Voltage to Drive IGBTs with up to 10 A Pulse Current
- 3 V TTL Logic Level Microcontroller Interface
- Non-Overlap Operation of High Side and Low Side Drivers allows use Single Signal Source to drive Half-Bridge Modules
- Hardware-programmable Dead Time
- Single 15 V Power Supply Operations
- Gate current ±10A
- Under- and Over-Voltage Lockout Protection
- Up to 50 mA 3.3 V Load Capability Output to Drive an External MCU
- Cycle-by-cycle IGBT Over-current Protection
- Advanced Active Clamping
- FAULT Signals Informing MCU about Over-Voltage, Under-Voltage, and Over-Current Conditions at Isolated Gate Drivers
- Latched FAULT Signals from Gate Drivers to Let MCU Read Fault Information Asynchronously
- Operating Ambient Temperature: -400C~+1050C
- Driver and Internal Power Supply Over- Temperature Protection with 1500C Threshold and 250C Hysteresis
- Footprint: 50 mm x 50 mm

# KEY DATA OVERVIEW

Parameter	Min	Typical	Max	Unit	
Nominal supply voltage	12	15	16	V	
Supply current @ f <sub>IN</sub> =0 Hz		25		mA	
Supply Current at Full Load		160		mA	
Output power per channel		2		W	
Gate voltage swing	Positive	12	15	20	V
	Negative	-10	-7.5	-5	V
Peak output current	-10		+10	A	
Minimum Pulse Width		500		ns	
Input Signal Propagation Delay Time		100		ns	
Input Pulse Width Distortion	-20		+20	ns	
Input Pulse Duty cycle	0		100	%	
Dead Time Programmability Range	50		2000* $\text{C}$ (F)	ns	
Fault Signals Propagation Delay Time		100		ns	
ACL Comparator Threshold (to VEE)		3.1		V	
Over-current Comparator Threshold (to COM)		300		mV	
MCU Supply Output Voltage		3.3		V	
MCU Supply Short Circuit Current		100		mA	
Operating temperature	-40		+105	OC	
Dielectric test voltage	4000			VAC	

## BASIC SCHEMATIC OF THE IXIDM1401

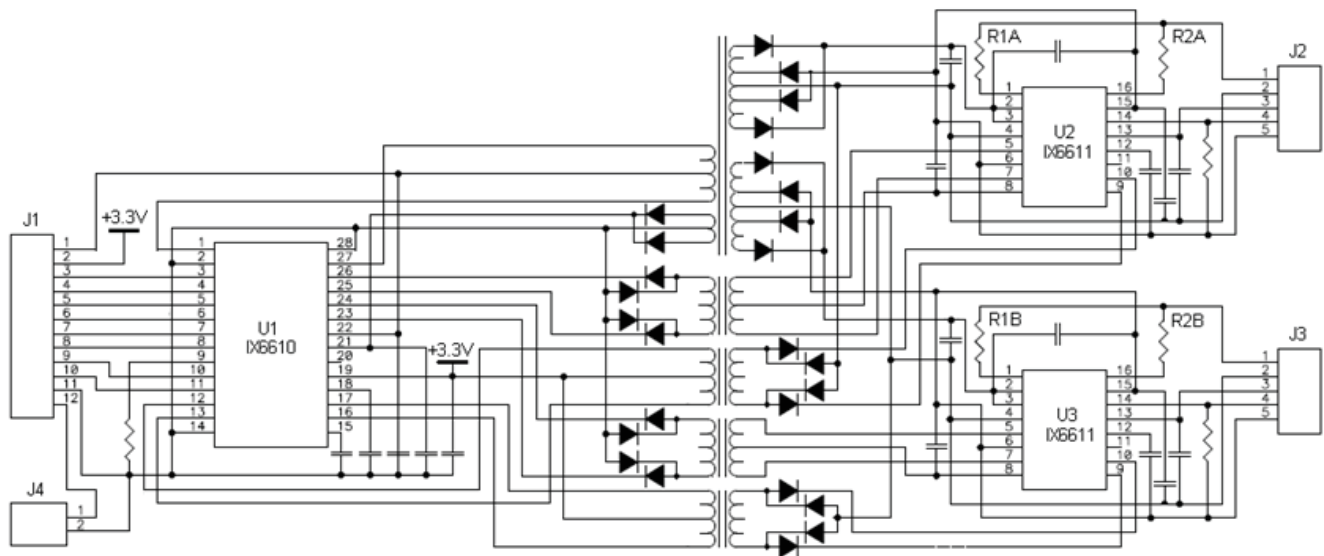

The IXIDM1401 targets medium-power, half-bridge IGBT and MOSFET applications. The driver supports switching up to 250 kHz at best-in-class efficiency. The IXIDM1401 comprises a complete dual-channel IGBT driver core, fully equipped with an isolated DC/DC converter, short-circuit protection, advanced active clamping and supply-voltage monitoring. It is a driver core equipped with the IXYS Corporation IX6610/6611 chipset of application-specific integrated circuits that covers the main range of functions needed to design intelligent gate drivers.

## ORDERING INFORMATION

### 4. ORDERING INFORMATION

IXIDM①②③④\_⑤\_⑥⑦⑧\_⑨

DESIGNATORS	DESCRIPTION	SYMBOL	DESCRIPTION
①	Module Configuration	1	Two Isolated Gate Drivers
②③	Isolation Voltage	40	4.0 kV
④	Gate Current	1	10 A
⑤⑥	Positive Gate Voltage	15	15 V
⑦⑧	Negative Gate Voltage	05	-5 V
⑦⑧	Negative Gate Voltage	15	-15 V
⑨	Package Information		O – Open Frame, M - Molded

### PART NUMBERS AND ORDERING OPTIONS:

IXIDM1401\_1505\_O - two isolated gate drivers with 10 A gate current , 15 V positive and -5 V negative gate voltage, open frame version.

IXIDM1401\_1505\_M - two isolated gate drivers with 10 A gate current , 15 V positive and -5 V negative gate voltage, molded version.

IXIDM1401\_1515\_O - two isolated gate drivers with 10 A gate current , 15 V positive and -15 V negative gate voltage, open frame version.

IXIDM1401\_1515\_M - two isolated gate drivers with 10 A gate current , 15 V positive and -15 V negative gate voltage, molded version.