

PART NUMBER	ITEM ① BODY	ITEM ② CONTACT	ITEM ③ INSULATOR
142-0701-851	BRASS GOLD PL .00001 MIN OVER NICKEL PL .00005 MIN OVER COPPER PL .00005 MIN	BERYLLIUM COPPER GOLD PL .00003 MIN OVER NICKEL PL .00005 MIN OVER COPPER PL .00005 MIN	TEFLON
142-0701-856	BRASS NICKEL PL .0001 MIN OVER COPPER PL .00005 MIN	BERYLLIUM COPPER GOLD PL .00003 MIN OVER NICKEL PL .00005 MIN OVER COPPER PL .00005 MIN	TEFLON

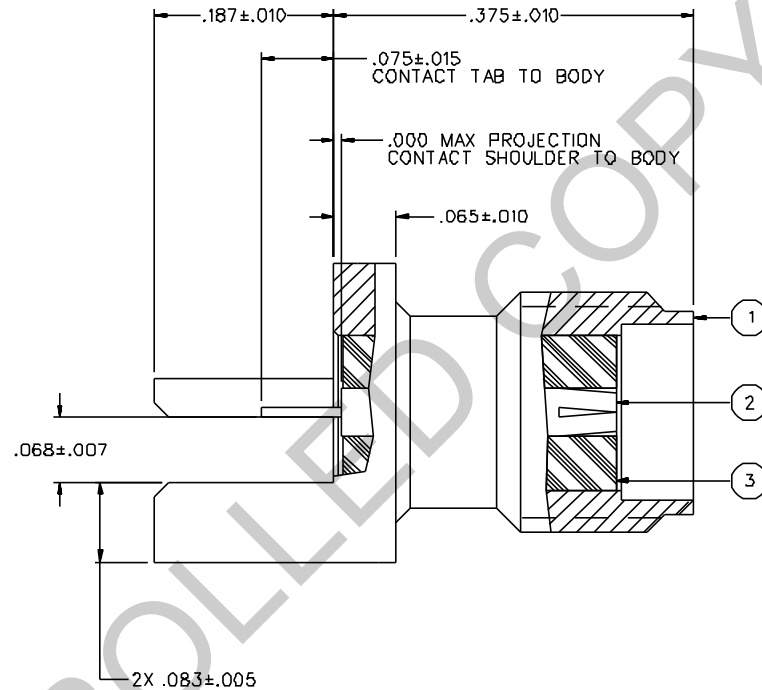
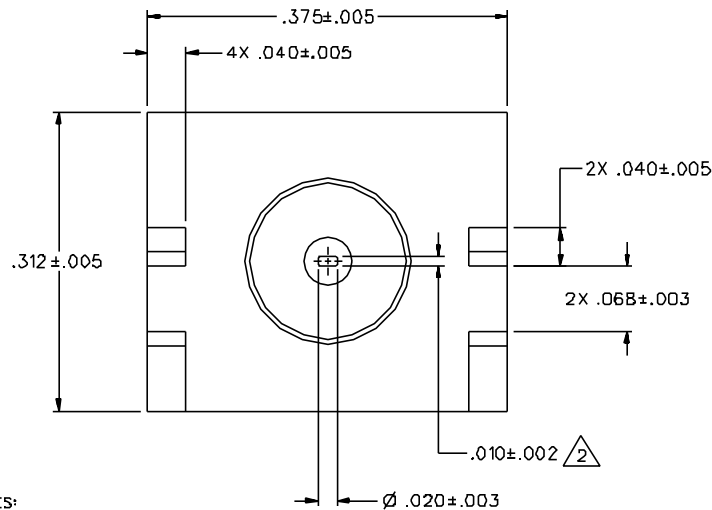

NOTES:

1. SPECIFICATIONS:

ELECTRICAL:

IMPEDANCE: 50 OHMS  
 FREQUENCY RANGE: 0-18 GHz  
 VSWR: NOT APPLICABLE  
 WORKING VOLTAGE: 335 VRMS MAX AT SEA LEVEL  
 DIELECTRIC WITHSTANDING VOLTAGE: 1000 VRMS MIN AT SEA LEVEL  
 INSULATION RESISTANCE: 5000 MEGOHMS MIN  
 CONTACT RESISTANCE: CENTER CONTACT - INITIAL 3 MILLIOHMS MAX,  
 AFTER ENVIRONMENTAL 4 MILLIOHMS MAX  
 OUTER CONDUCTOR - INITIAL 2.0 MILLIOHMS MAX  
 AFTER ENVIRONMENTAL NOT APPLICABLE  
 BRAID TO BODY - NOT APPLICABLE  
 CORONA LEVEL: 250 VOLTS MIN AT 70,000 FEET  
 INSERTION LOSS: NOT APPLICABLE  
 RF LEAKAGE: NOT APPLICABLE  
 RF HIGH POTENTIAL WITHSTANDING VOLTAGE: 670 VRMS MIN AT 4 AND 7 MHz

MECHANICAL:

ENGAGE/DISENGAGE TORQUE: 2 INCH POUNDS MAX  
 MATING TORQUE: 7-10 INCH POUNDS  
 COUPLING PROOF TORQUE: NOT APPLICABLE  
 COUPLING NUT RETENTION: NOT APPLICABLE  
 CONTACT RETENTION: 6 LBS MIN AXIAL FORCE  
 4 IN-OZ MIN RADIAL TORQUE  
 CABLE ACCEPTABILITY: NOT APPLICABLE  
 CABLE RETENTION: NOT APPLICABLE  
 DURABILITY: 500 CYCLES MIN

ENVIRONMENTAL:

(MEETS OR EXCEEDS THE APPLICABLE PARAGRAPH OF MIL-C-39012)  
 THERMAL SHOCK: MIL-STD-202, METHOD 107, CONDITION B  
 OPERATING TEMPERATURE: -65 °C TO 165 °C  
 CORROSION: MIL-STD-202, METHOD 101, CONDITION B  
 SHOCK: MIL-STD-202, METHOD 213, CONDITION I  
 VIBRATION: MIL-STD-202, METHOD 204, CONDITION D  
 MOISTURE RESISTANCE: MIL-STD-202, METHOD 106

2. BOTTOM OF CONTACT TO BE IN LINE WITH MOUNTING LEG WITHIN .010.

DRAWING NO. C - 142-0701-851/860	
0 REVISIONS	
ENGINEERING RELEASE	
1	10-26-92 R H [signature] 12-18-92 ECO 41347
CHANGED: .068±.007 WAS .068±.003, UPDATED GRAPHICS ADDED: .025±.018	
1a	2-18-94 R H [signature] 3-8-94 ECO 42225
DELETED: -B55, NOTE 4 TIN DIP LEADS	
***** * REVISION NUMBER FOLLOWED BY AN ALPHA * * CHARACTER INDICATES DRAWING CLARIF. * * CATION OR PART NUMBER ADDITION ONLY. *	
1b	6-11-94 R H [signature] 6-21-94 ECN 42519
CHANGED: 4X .040±.005 WAS 2X .040±.005 ADDED: .000 MAX PROJECTION, .075±.015 DELETED: .025±.005, .025±.015, .100±.015, .000±.017, .000±.018 NOTE 2 AND RENUMBERED OTHERS	
2	2-20-97 R H [signature] ECN 44267

CUSTOMER DRAWING

THIS DRAWING TO BE INTERPRETED PER ANSI Y 14.5M - 1982

"μSTATION"

COMPANY CONFIDENTIAL

TOLERANCE UNLESS OTHERWISE SPECIFIED	DRAWN BY VET	DATE 9-17-92	JOHNSON® Cinch Connectivity Solutions 299 Johnson Ave. Ste. 100 Worcester, MA 01603 1-800-247-8256	
DECIMALS .XX	CHECKED BY	DATE	TITLE JACK ASSEMBLY END LAUNCH SMA	
MATL	APPROVED BY VET	DATE 11-18-92	CODE NO.	DRAWING NO. C - 142-0701-851/860
FINISH	APPROVED BY TAK/RJB	DATE 11-30-92	SCALE 10:1	U/W INCH SHEET 2 OF 2
	RELEASE DATE	12-18-92		