

4

3

2

1

REVISIONS		DESCRIPTION		DATE	DWN	APVD
A1		REVISED PER ECR-17-014412		03APR18	NG	MKO

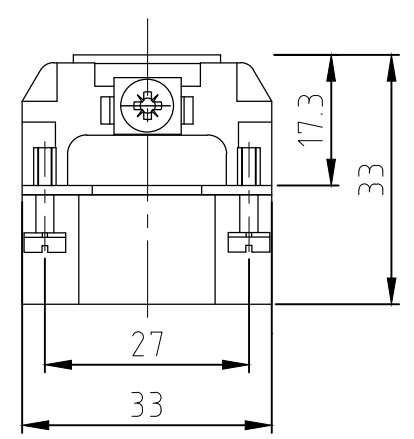
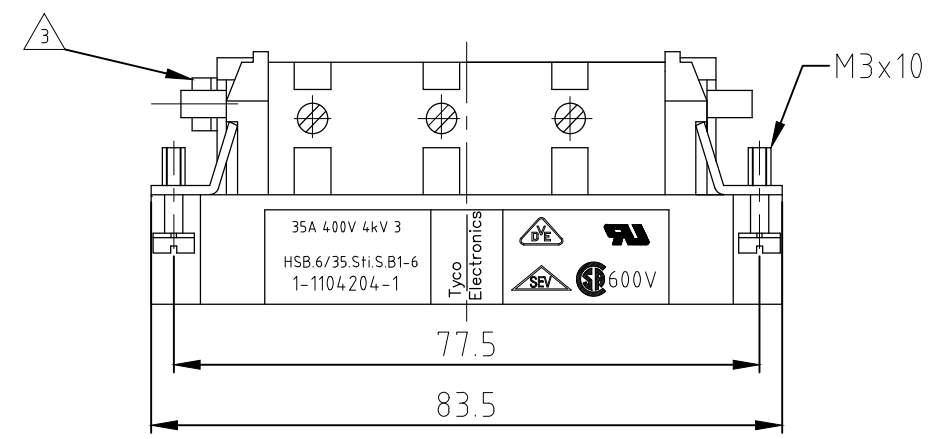

- NOTES
- 1 FINISH: CONTACT , AG
 - 2 POWER CONTACT: 1 TO 6
OUTER DIMENSIONS OF INSULATION: MAX. ϕ 7.0 MM
 - 3 GROUNDING CONTACT
 - 4 SUITABLE HOOD SIZE 6: SERIES HB; HD; EMV; HIP
 - 5 STANDARDS:
DIN EN 61984; DIN EN 60664-1
 - 6 PACKAGING: 5 PIECES IN A CARTON
 - 7 PACKAGING: 200 PIECES IN A BOX

Contact arrangement view from termination side

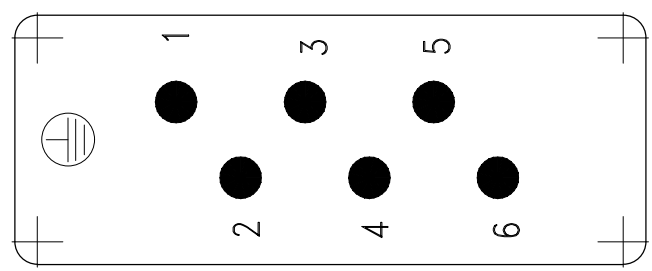

Panel cut-out for contact insert when used without housing

Assembling instruction

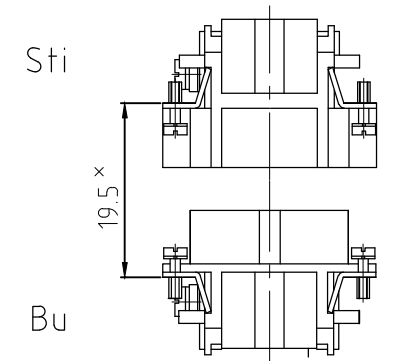

x Distance for guaranteed contact max: 21 mm

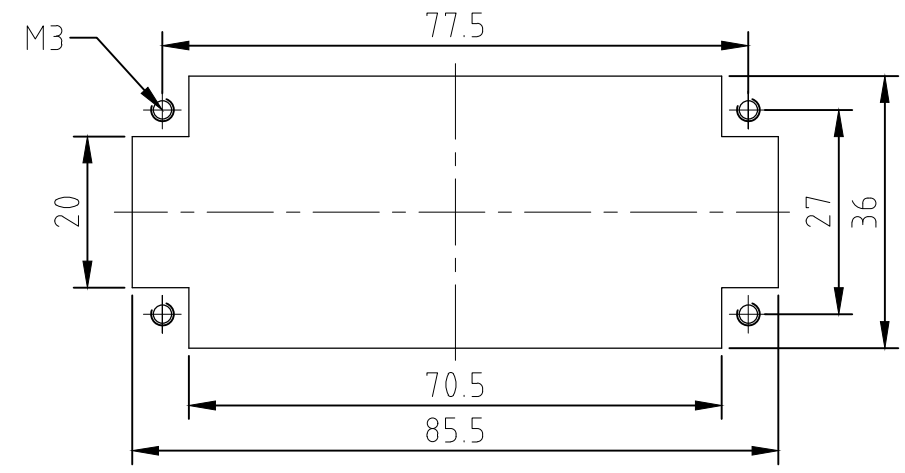

SUPERSEDED BY T20600062101-000

1	1	MALE INSERT	beige	1	-	
0-1	1-1	DESCRIPTION / BENENNUNG	MATERIAL	COLOR / FARBE	ITEM NO. POS.	REMARKS / BEMERKUNGEN
7	6	<small>THIS DRAWING IS A CONTROLLED DOCUMENT FOR AMP INCORPORATED. IT IS SUBJECT TO CHANGE AND THE CONTROLLING ENGINEERING ORGANIZATION SHOULD BE CONTACTED FOR THE LATEST REVISION. DIESES ZEICHNUNGSDOKUMENT WIRD DURCH AMP INCORPORATED KONTROLLIERT. AENDERUNGEN, DIE DEM TECHNISCHEN FORTSCHRITT DIENEN, SIND VORBEHALTEN. DEN JEWEILS LETZTGUELTIGEN AENDERUNGSSTAND ERFAHREN SIE AUF ANFRAGE.</small> DIMENSIONS: DIMENSIONEN: mm TOLERANCES UNLESS OTHERWISE SPECIFIED: ALLGEMEINTOLERANZEN n. ISO 8015 n. ISO 2768 - mH - E n. DIN 16901 - 14.0 0 PLC # 1 PLC # 2 PLC # 3 PLC # ANGLES / WINKEL # FINISH / OBERFLAECHE / FARBE	DWN Schweiger 18.06.1997	TE CONNECTIVITY		
HSB.6/35.Sti.S.B1-6.KM	HSB.6/35.Sti.S.B1-6		CHK Kramer 04.06.98	APVD -	NAME MALE INSERT HSB.6/35.Sti.S.B1-6	
ORDERING TEXT / BESTELLTEXT		MATERIAL	WEIGHT GEWICHT 86 g	SIZE A3	CAGE CODE 00779	DRAWING NO ZEICHNUNGS-NR. C-1104204
CUSTOMER DRAWING			/KUNDENZEICHNUNG		MASSSTAB 1:1	BLATT 1 OF VON 1
						RESTRICTED TO NUR FUER -
						REV A5