



3-phase plus neutral star point snubber with excellent attenuation to reduce dV/dt

Datasheet 3/2017

APPROVALS:

FIN47SNB.050.1M
FEATURES

- Reduces dV/dt
- Protection of motor winding insulation and bearings
- Remote contact indicator
- Compact dimension due to the parallel installation

BENEFITS

- Very low power loss
- Available with remote electronic control
- Easy installation
- Only one model for unlimited HP motors

MARKETS

- Large motors
- Spindle motors
- Long cable applications with variable frequency drives or servo drives

ORDERING CODE

FIN47SNB	.050	.1M	.A	MSD1
Model	Impedance	Connection	Fan nominal voltage	Electronic control
		1M = 1 motor	A = 24Vdc B = 24Vac	MSD1 at 24Vdc
		2M = 2 motors	C = 110Vac D = 220Vac	MSD2 at 230Vac

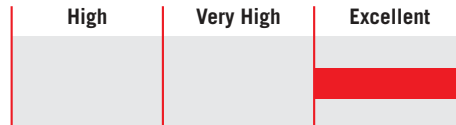
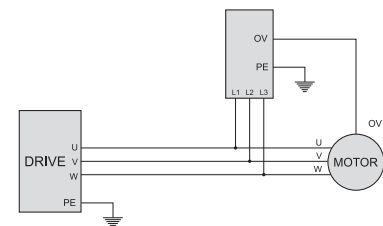
ATTENUATION INDICATOR

ELECTRIC DIAGRAM

TECHNICAL SPECIFICATIONS

Nominal voltage	0 / 600 Vac
Frequency	50 – 1000 Hz
Rated current	Unlimited
Carrier frequency (PWM)	0 - 5 kHz
Max peak voltage phase to phase	3000V
Max peak voltage phase to ground	3500V
Max power dissipation	250W
Fan dissipation	20W
IP protection	IP20
Climatic class	-40 / +85° C
MTBF at 40°C	250.000 Hrs.

ELECTRICAL CHARACTERISTICS

FIN47SNB	Nominal Voltage AC (Vac)	Drive Carrier Frequency (KHz)	Power Loss at 100Hz (W)
.050.1M	600	<5	250

CONNECTIONS

LINE			PE	
Solid Cable (mm ²)	Stranded Cable (mm ²)	Terminal Torque (Nm)	d (mm)	Torque (Nm)
10 - 50	10 - 50	4.0	M10	6

TYPICAL MEASUREMENT

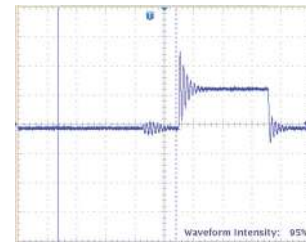

Typical measurement of dV/dt without snubber installed

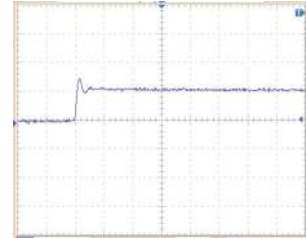

Typical measurement of dV/dt with snubber installed

MECHANICAL DIMENSIONS mm

FIN47SNB	A	B	C	D	E	F	G	H	I	J	M	L	d	Weight Kg.	Case
.050.1M.X.Y	235	167	246.5	125	110	83	125	8.5	4	13.5	10	15	M10	5	1
.050.2M.X.Y	235	368	376.5	125	110	83	105	5.4	4	8.5	-	15	M10	10	2

CASE 1

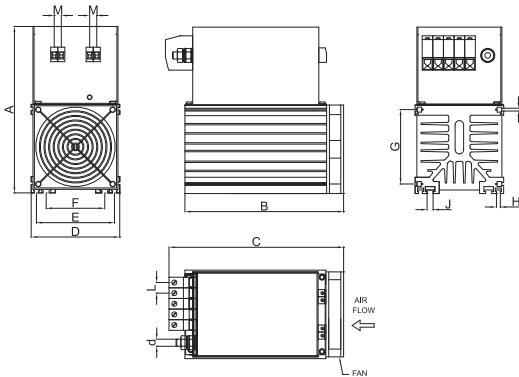

CASE 2

