

HDC2010EVM User's Guide

User's Guide



Literature Number: SNAU214
July 2017

1	Introduction	6
2	Setup	6
	2.1 Input/Output Connector Description	7
	2.2 Hardware Setup	7
	2.3 Software Setup	8
	2.4 Operation	13
	2.5 Reducing the Sensor Thermal Mass	14
3	GUI Operation	14
	3.1 Starting the GUI.....	15
	3.2 Connecting the EVM	16
	3.3 Navigating the GUI	18
	3.4 Configuring the Device Using Register Page	20
	3.5 Configuring the Device using Configuration Page.....	28
	3.6 Streaming Measurement Data	29
	3.7 Updating the EVM Firmware	39
4	Board Layout	43
5	Schematic	44
6	HDC2010EVM Bill of Materials	45

List of Figures

1	HDC2010EVM.....	6
2	HDC2010EVM : Sensor Module	7
3	HDC2010EVM: Layout Resistors for I2C Address Setting - Top.....	8
4	GUI Installer Welcome Page	9
5	GUI Installer License Agreement.....	10
6	GUI Installer Installation Directory	10
7	GUI Installer Copying Files.....	11
8	EVM Driver Installer Welcome Page.....	11
9	EVM Driver Installer In Progress	12
10	EVM Driver Installer Complete	12
11	GUI Installer Complete	13
12	HDC2010EVM : PC Interface and Sensor Module	14
13	HDC2010EVM : PC Interface and Smaller Sensor Module	14
14	HDC2010EVM : Pads for I2C and Supply of the Smaller Sensor Module.....	14
15	GUI Splash Screen.....	15
16	GUI Introduction Page	16
17	GUI Disconnected from EVM	17
18	GUI Connected from EVM	17
19	GUI Menu Button.....	18
20	GUI Navigation Menu	19
21	Selecting Auto-Read Interval on Register Page.....	20
22	Selecting a Register's Current Value for Editing on Register Page	21
23	Entering New Value for Register on Register Page	21
24	Register Value Updated After Changing Value on Register Page.....	22
25	Hovering Mouse Over Register Bit Value on Register Page	22
26	Toggling Register Bit Value on Register Page	23
27	Selecting a Register on Register Page.....	24
28	Reading the Current Device Register Value on Register Page	24
29	Save Register Values to File on Register Page.....	25
30	Choosing a JSON File Name to Save Register Values	26
31	Loading Previously Saved Register Values from File on Register Page	27
32	Selecting Previously Save Register Value JSON File.....	27
33	HDC2010 GUI Configuration Page	28
34	Selecting the Measurement Units for the Data Streaming Graph	29
35	Data Streaming Graph Showing Only Relative Humidity Percent	30
36	Data Streaming Graph Showing Only Temperature	30
37	Select Log File Button on Data Streaming Page.....	31
38	Selecting the Log File for Data Streaming	32
39	Show Graph Configuration Button on Data Streaming Page.....	33
40	Setting the Data Streaming Sample Rate to 1 Second	33
41	Manually Setting the Vertical Scale on Data Streaming Graph	34
42	Starting Data Acquisition on Data Streaming Graph	35
43	Data Acquisition In Progress on Data Streaming Page	35
44	Stopping Data Acquisition on Data Streaming Graph.....	36
45	Show Statistics Button on Data Streaming Graph	37
46	Data Statistics on Data Streaming Graph.....	37
47	Moving the Data Graph Sample View	38

48	Viewing the Entire Buffer on Data Graph	39
49	Select TI-TXT File Button on Firmware Upload Page	40
50	Selecting TI-TXT Firmware File for Upload to EVM	40
51	Upload Firmware Button on Firmware Upload Page	41
52	Firmware Upload in Progress.....	41
53	Firmware Upload Success	42
54	Top Layer Routing	43
55	Bottom Layer Routing.....	43
56	HDC2010EVM Schematic.....	44

List of Tables

1	Device and Package Configurations	6
2	I2C Address	8

HDC2010EVM User's Guide

1 Introduction

The Texas Instruments HDC2010EVM evaluation module (EVM) enables designers to evaluate the operation and performance of the HDC2010 Relative Humidity and Temperature Sensor.

The EVM contains one HDC2010 (See [Table 1](#)).

Table 1. Device and Package Configurations

DEVICE	IC	PACKAGE
U1	HDC2010YPAR	DSBGA - 6 pin (YPA0006)

The EVM hosts an MSP430F5528 microcontroller (μC) as well as the HDC2010. The μC is used to control the HDC2010 and communicate with a host PC through a USB port. The EVM is designed to be broken into two sections if desired. The sensor section can be separated from the μC section so that the user can remotely locate the sensor from the μC section.

2 Setup

This section describes the connectors on the EVM as well and how to properly connect, setup and use the HDC2010EVM.

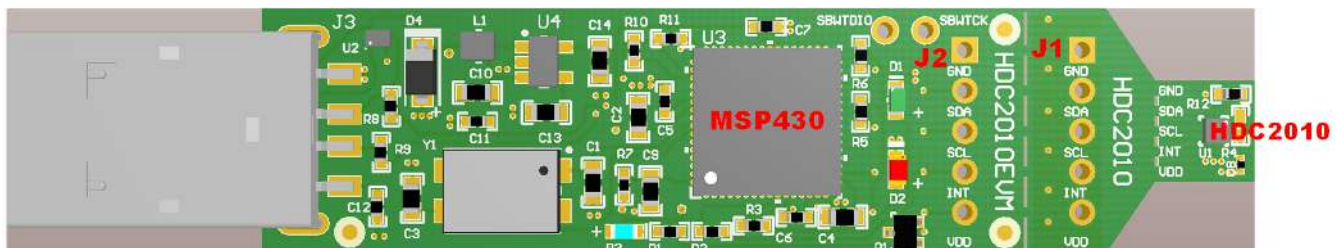

Figure 1. HDC2010EVM

2.1 Input/Output Connector Description

2.1.1 J1 – 5x1 Header

This header is not populated and can be installed if the EVM is broken in 2 sections: PC interface and Sensor. This connector with its counterpart J2 allows the communication of the two sections through a 5-wire cable

J1.1	GND
J1.2	SDA
J1.3	SCL
J1.4	INT
J1.5	VDD

2.1.2 J2 – 5x1 Header

This header is not populated and can be installed if the EVM is broken in 2 sections: PC interface and Sensor. This connector with its counterpart J1 allows the communication of the two sections through a 5-wire cable.

J2.1	GND
J2.2	SDA
J2.3	SCL
J2.4	INT
J2.5	VDD

2.1.3 USB Type A Connector

This connector is used for communications with the PC and provides power for the EVM.

2.2 Hardware Setup

The HDC2010EVM power is supplied via the USB connector. The LDO (U4) converts the 5V from the USB to 3.3V used by the HDC2010 and the MSP430. The EVM may be directly inserted into a USB port on a PC or laptop, or may be connected to the latter using the appropriate USB cable.

The I2C address of the HDC2010 is set at EVM level at 1000000xb on the EVM. The I2C address has been set mounting the 0 Ω resistor R12 (refer to [Figure 2](#)).

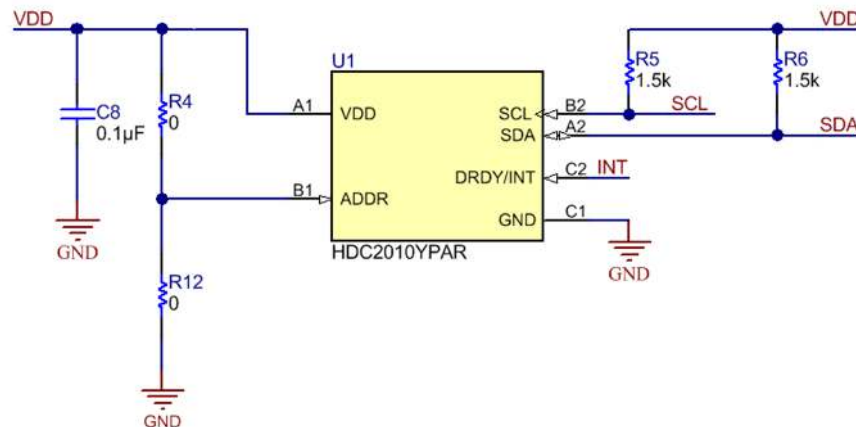

Figure 2. HDC2010EVM : Sensor Module

In order to change the I2C address, remove the resistor R12 and populate the R4 with 0 Ω resistor (refer to [Figure 3](#))

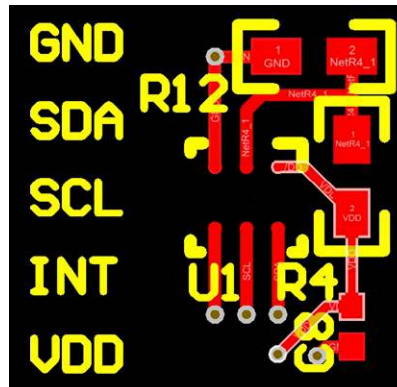

Figure 3. HDC2010EVM: Layout Resistors for I2C Address Setting - Top

Table 2. I2C Address

ADDR	R12	R4	HDC2010 ADDRESS
0	Short	Open	1000000
1	Open	Short	1000001

In [Table 2](#), the EVM default configuration is in **bold**.

2.3 Software Setup

2.3.1 System Requirements

The Sensing Solutions GUI supports:

- 64-bit Windows 7
- 64-bit Windows XP

The current GUI does not support 32-bit Windows operating systems. The host machine is required for device configuration and data streaming. The following steps are necessary to prepare the EVM for the GUI:

- The GUI and EVM driver must be installed on the host.
- The EVM must be connected to a full speed USB port (USB 1.0 or above).

2.3.2 Sensing Solutions GUI and EVM Driver Installation

The Sensing Solutions GUI and EVM driver installer is packaged in a zip file. Follow these steps to install the software.

1. Download the software ZIP file from the EVM tool page
2. Extract the downloaded ZIP file
3. Run the included executable
4. Follow all directions from the installer

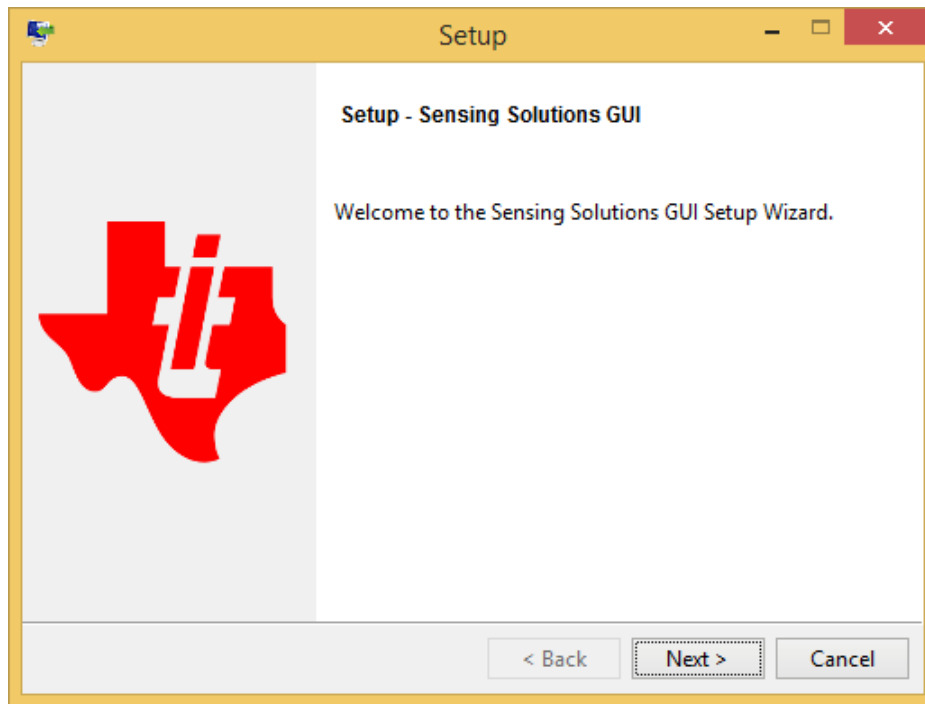

Figure 4. GUI Installer Welcome Page

5. Read the license agreement and if you still wish to install the software, select “I accept the agreement” and click “Next” as shown in

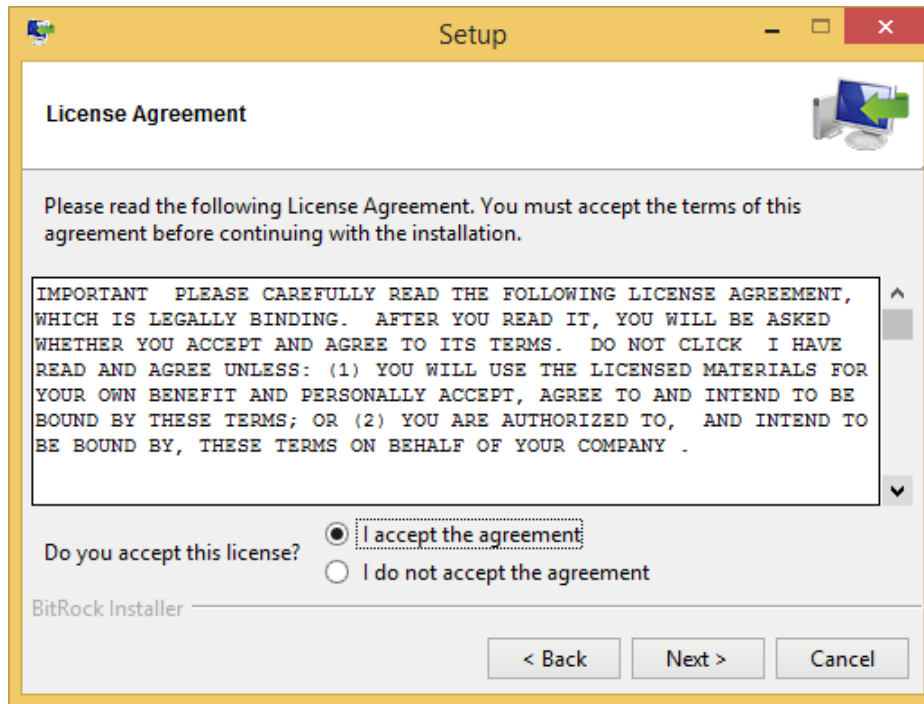

Figure 5. GUI Installer License Agreement

6. Select the installation directory. If the user installing the software is not a system administrator a directory not with “Program Files” should be chosen instead of the default.

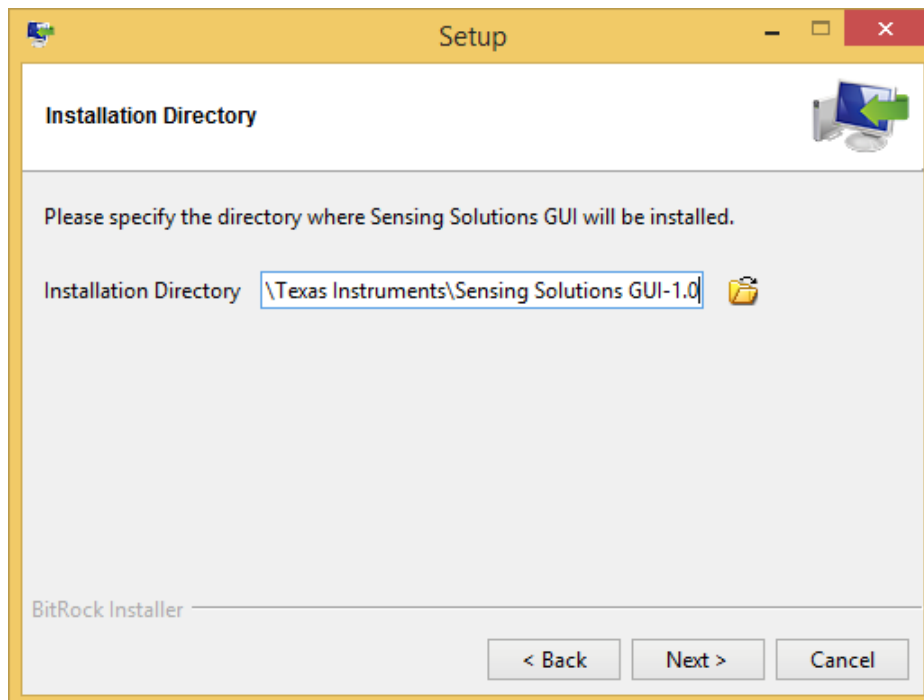

Figure 6. GUI Installer Installation Directory

7. Wait for all files to install

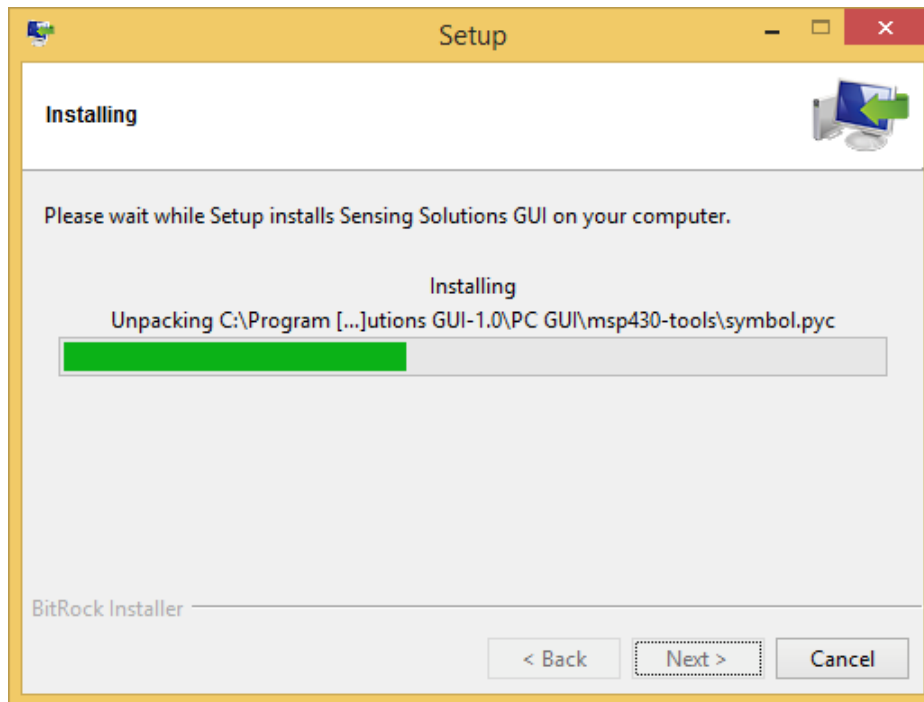

Figure 7. GUI Installer Copying Files

8. After the files have copied a device driver installer will start. If prompted about an unsigned driver, choose to install the driver anyways. If running Windows 8 or 8.1, the PC must be started in a “Safe” mode to install the unsigned driver.

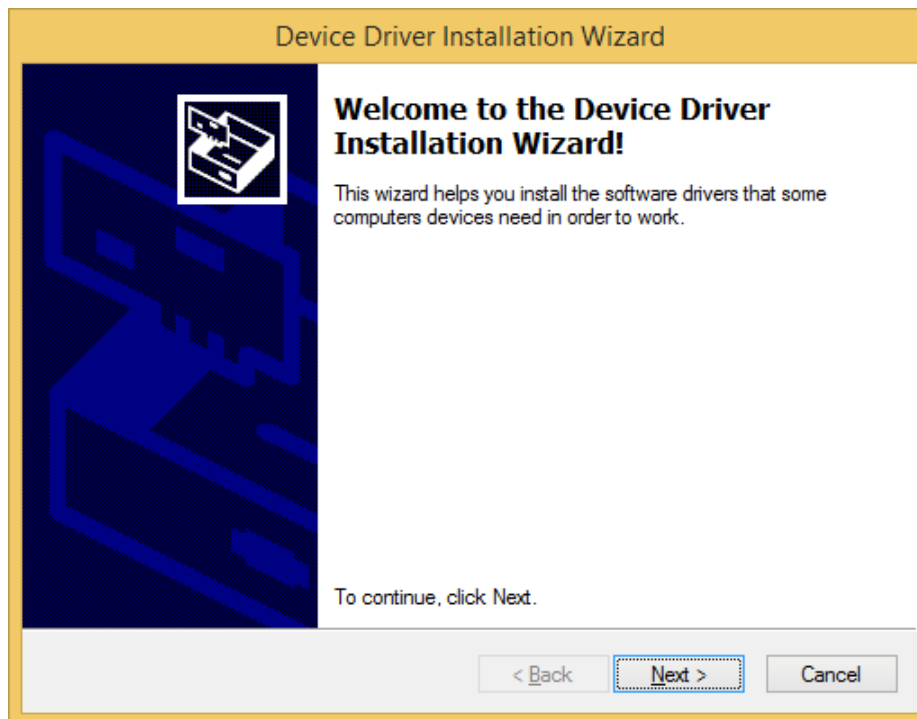

Figure 8. EVM Driver Installer Welcome Page

9. Wait for the driver to install

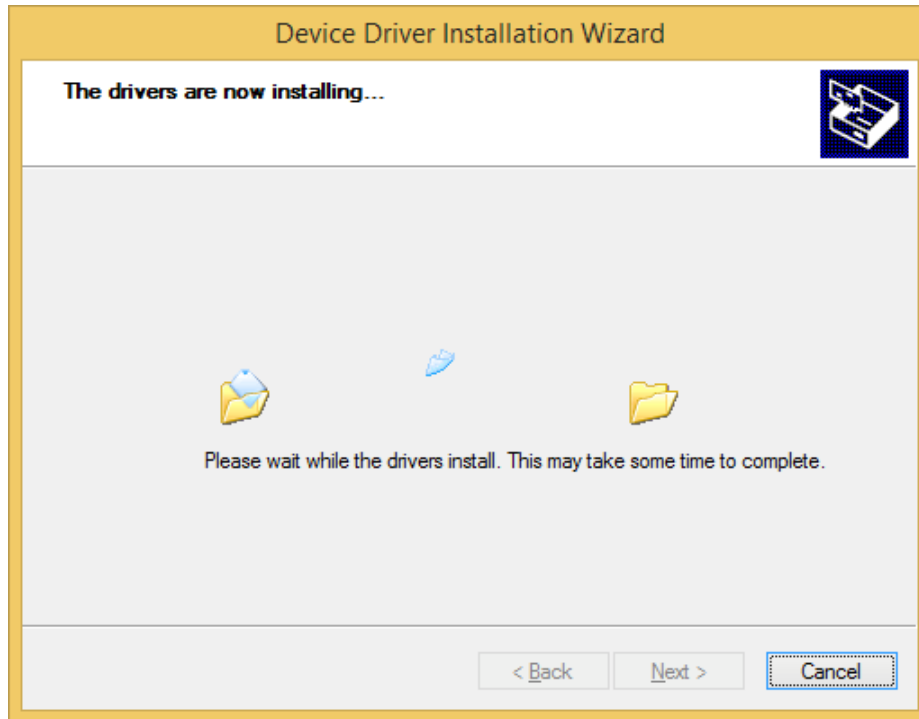

Figure 9. EVM Driver Installer In Progress

10. Click "Finish" after the driver has been installed

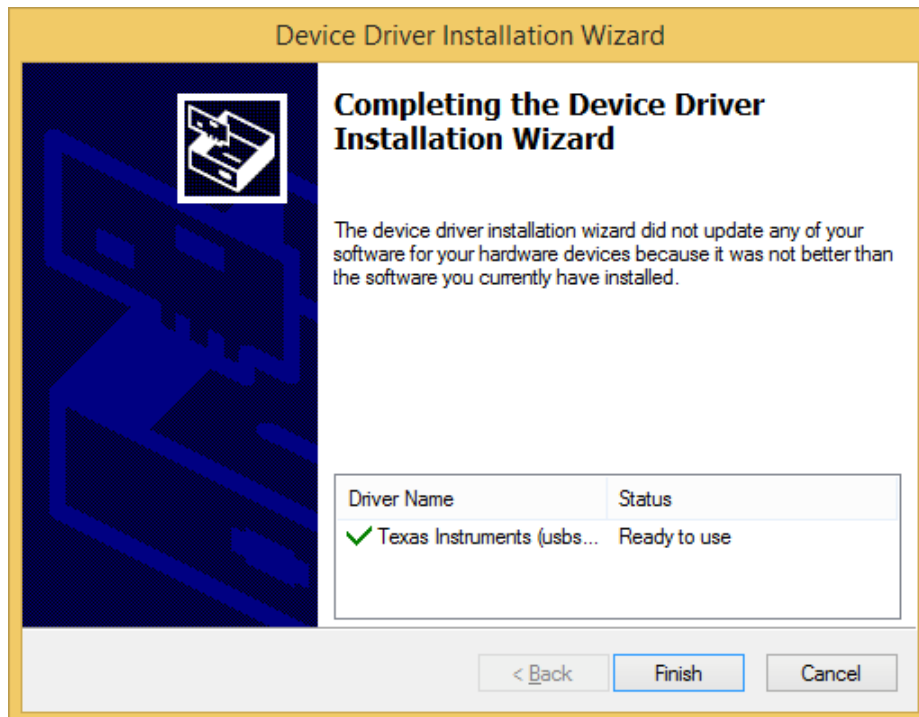

Figure 10. EVM Driver Installer Complete

11. Click “Finish” to complete the software installation

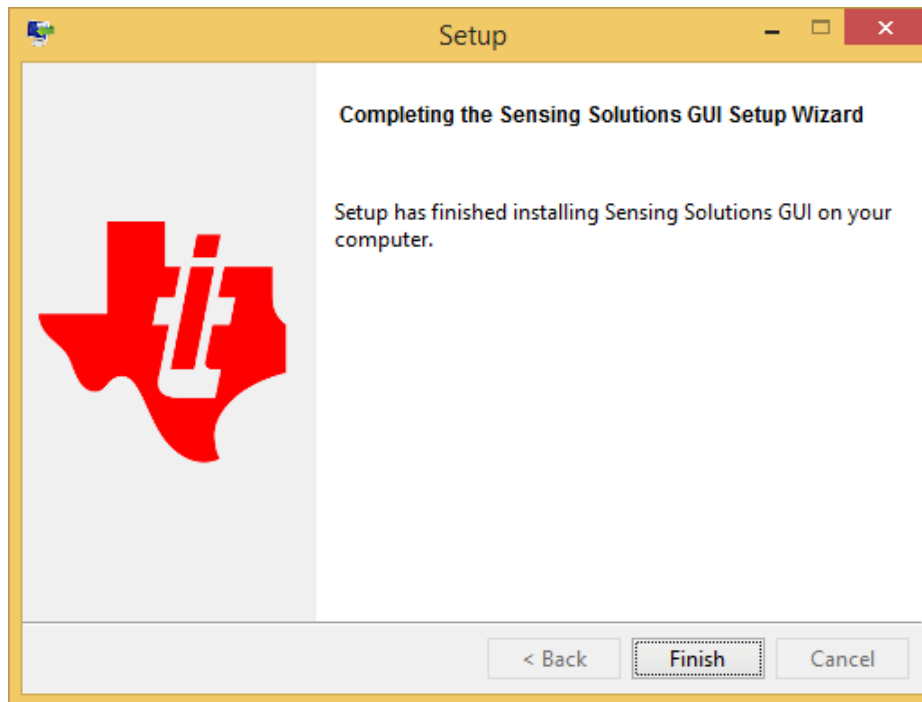

Figure 11. GUI Installer Complete

2.4 Operation

When the EVM is connected to the host computer, the latter should automatically detect the device. Launch the GUI. A detailed description of the GUI operation is presented later in this document.

2.5 Reducing the Sensor Thermal Mass

The HDC2010EVM can be broken into 2 sections to isolate the thermal mass of the μC from the HDC2010. [Figure 12](#) shows the board perforations that allow the two sections to be broken apart.

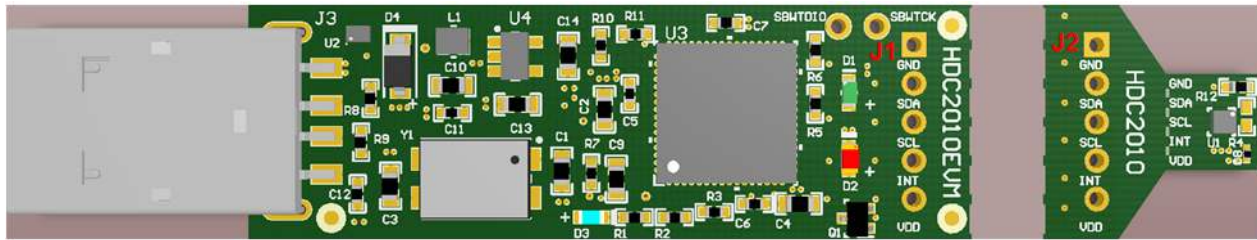

Figure 12. HDC2010EVM : PC Interface and Sensor Module

The communication between the two modules is ensured through the connector J1 and J2 and a 5-wire cable. In this configuration the thermal mass of the EVM is dramatically reduced, improving the temperature measurements performances of the HDC2010. The cable connecting J1 to J2 must conform to I2C cable length constraints. When used in this configuration, the GUI can still be used to communicate with the EVM and collect data.

If the thermal mass of the sensor section is still excessive, the sensor section can be reduced by breaking it at the perforation shown in [Figure 13](#). The PCB segment that hosts the HDC2010 is 5.5mm x 5mm.

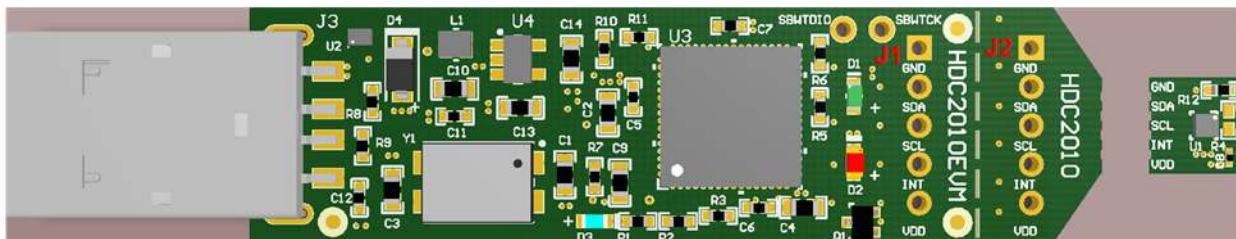

Figure 13. HDC2010EVM : PC Interface and Smaller Sensor Module

Also in the case where the EVM is broken in 2 sections it is still possible to use the GUI (ensuring the connections between the modules) or alternatively it is possible to connect the sensor module to a custom micro-controller. (Refer to [Figure 14](#)).

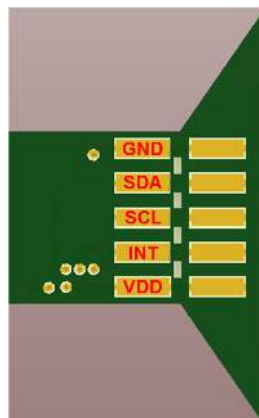

Figure 14. HDC2010EVM : Pads for I2C and Supply of the Smaller Sensor Module

3 GUI Operation

The section describes how to use the GUI

3.1 Starting the GUI

Follow these steps to start the GUI:

1. Select the windows start menu
2. Select "All programs"
3. Select the "Texas Instruments" folder
4. Select the Sensing Solutions GUI
5. Click "Sensing Solutions GUI"
6. Splash screen will appear for at least two seconds.
 - Slower PC's may show a blank splash screen without any texts for up to 20 seconds



Figure 15. GUI Splash Screen

7. After the splash screen is displayed the main window will open. Note: Only one instance of the GUI may be open at a time!

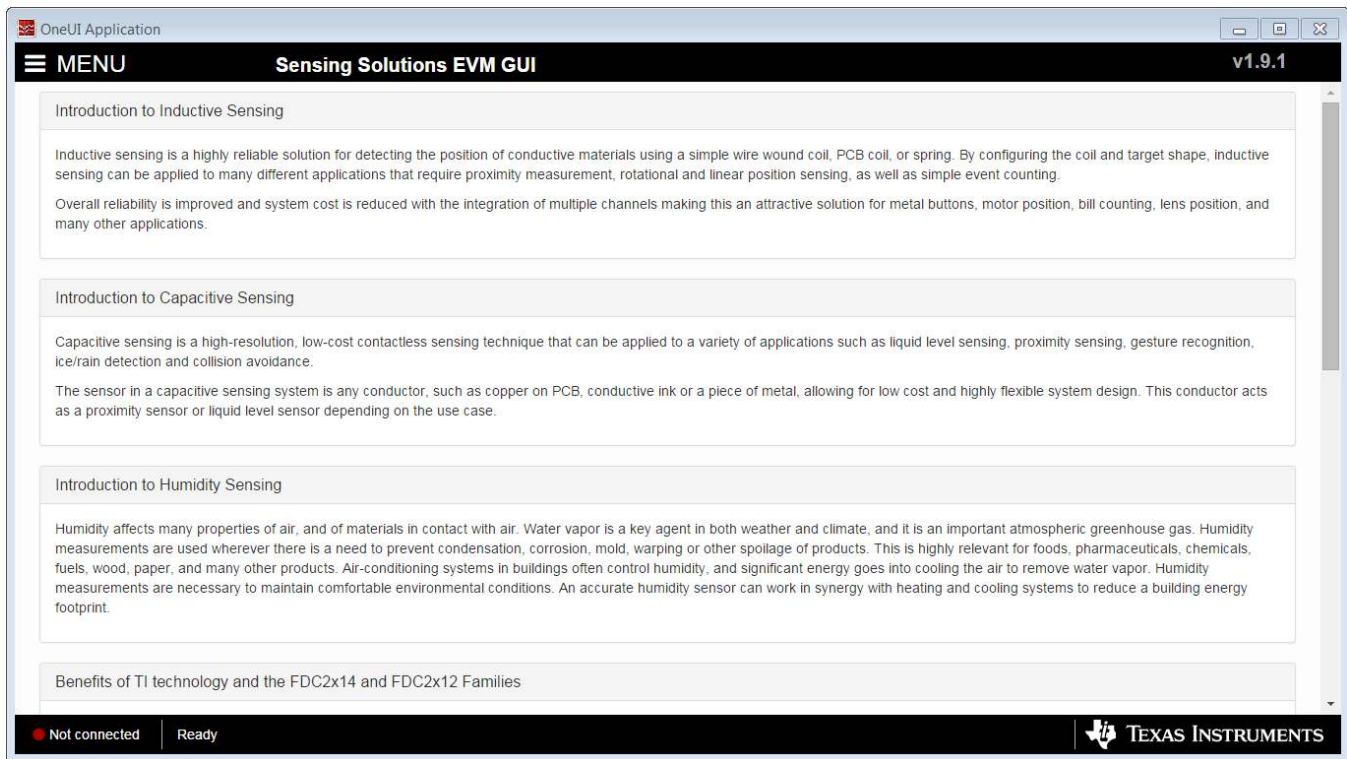

Figure 16. GUI Introduction Page

3.2 Connecting the EVM

Follow these steps to connect the EVM to the GUI:

1. Attach the EVM to the computer via the USB port.
2. The GUI always shows the connection status on the bottom left corner of the GUI
 - The initial release of this GUI does not support multiple GUI instances or multiple devices. To control multiple EVMs, virtual machines may be used or multiple PC's are required. Future releases will support multiple EVMs from a single instance of the GUI.

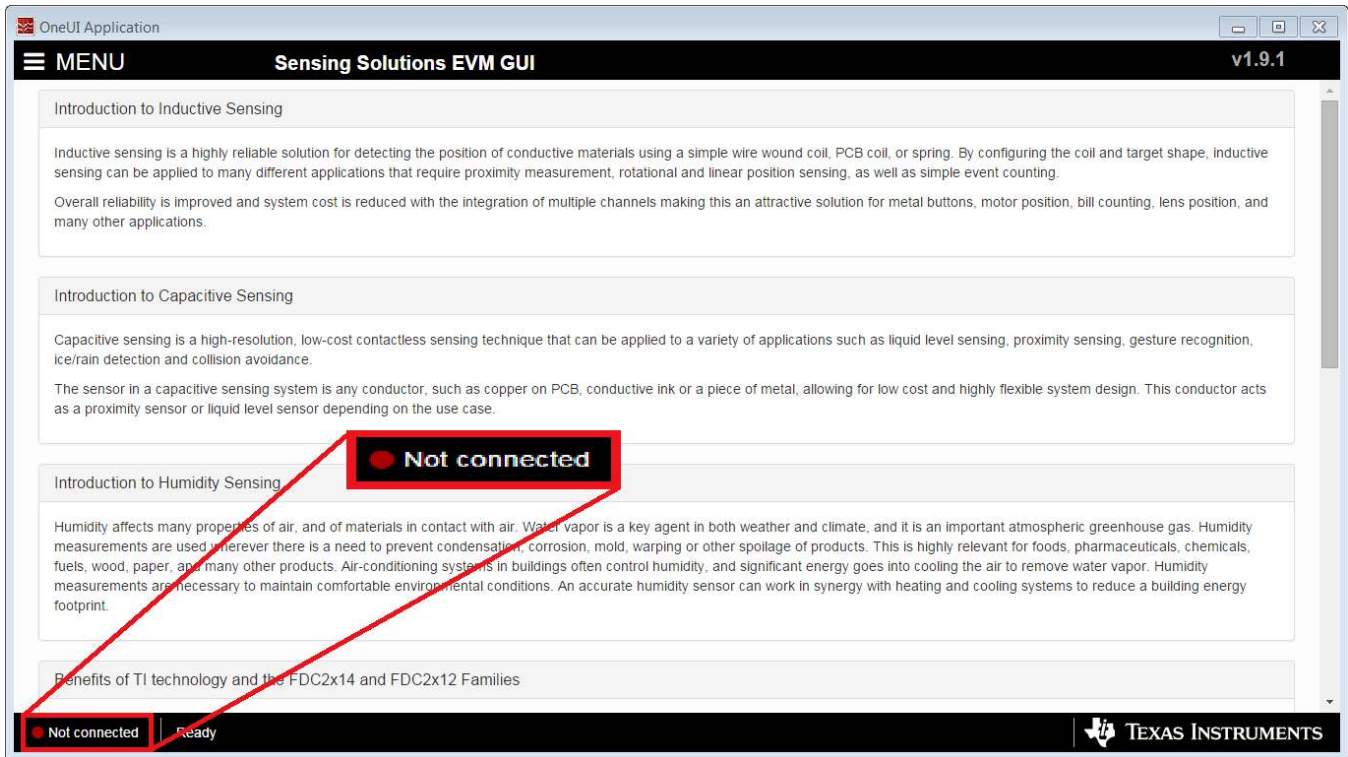

Figure 17. GUI Disconnected from EVM

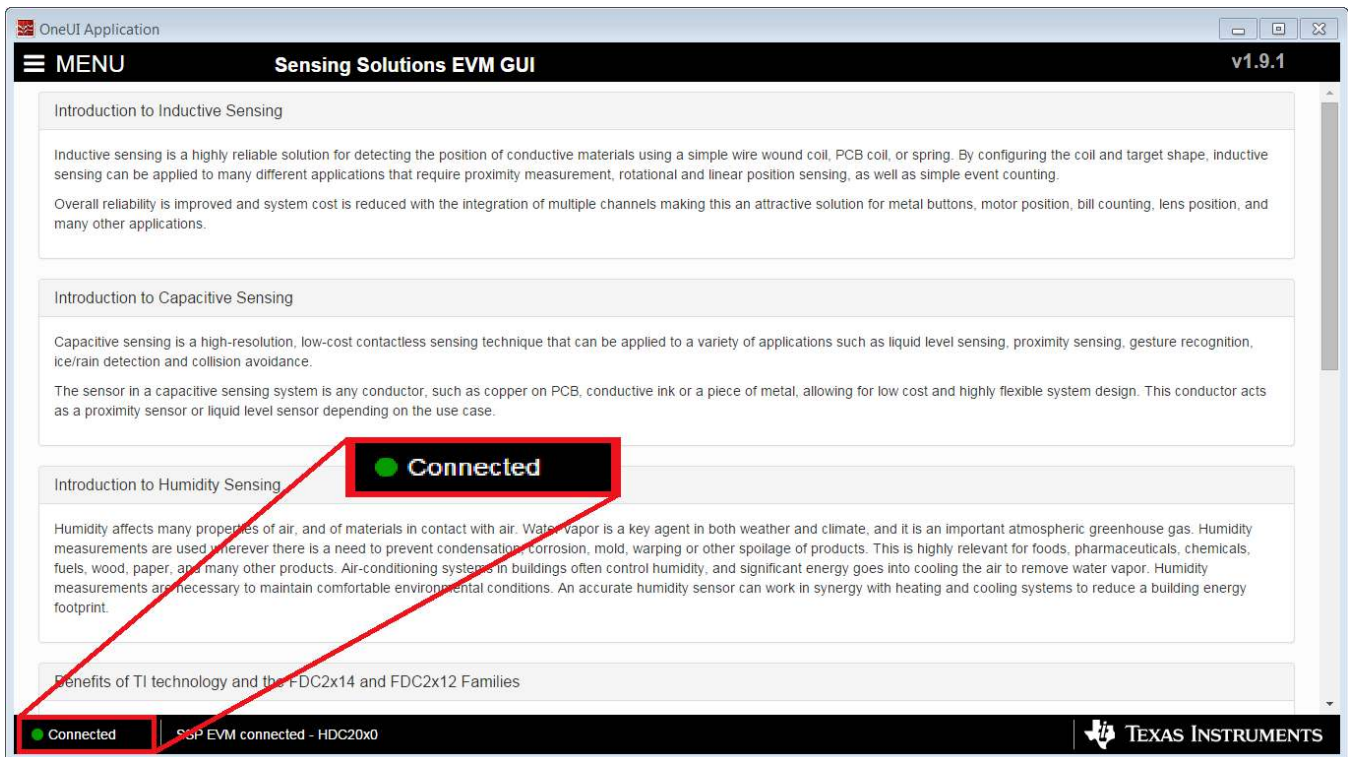

Figure 18. GUI Connected from EVM

3.3 Navigating the GUI

To navigate to different pages of the GUI follow these steps:

1. Click “Menu” in the upper left corner

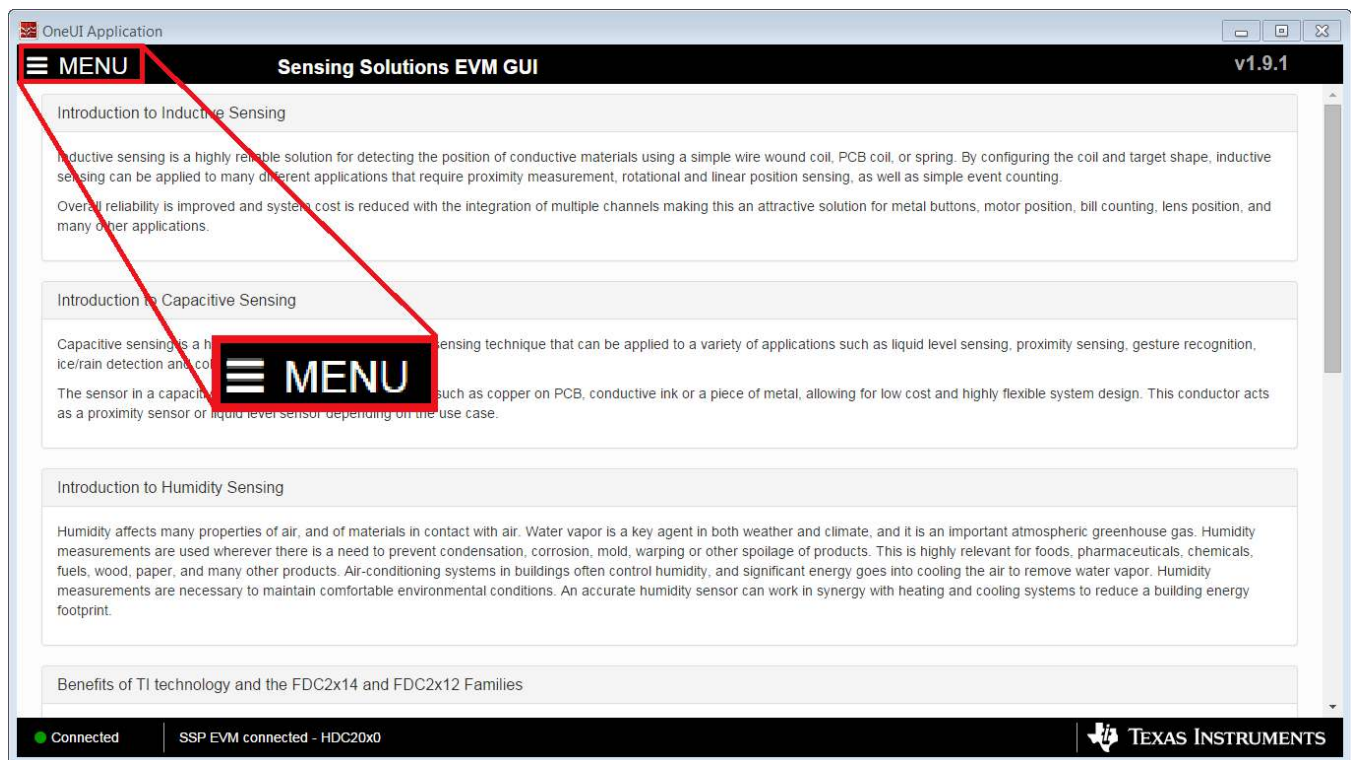

Figure 19. GUI Menu Button

2. Select the desired page from the menu shown on the left

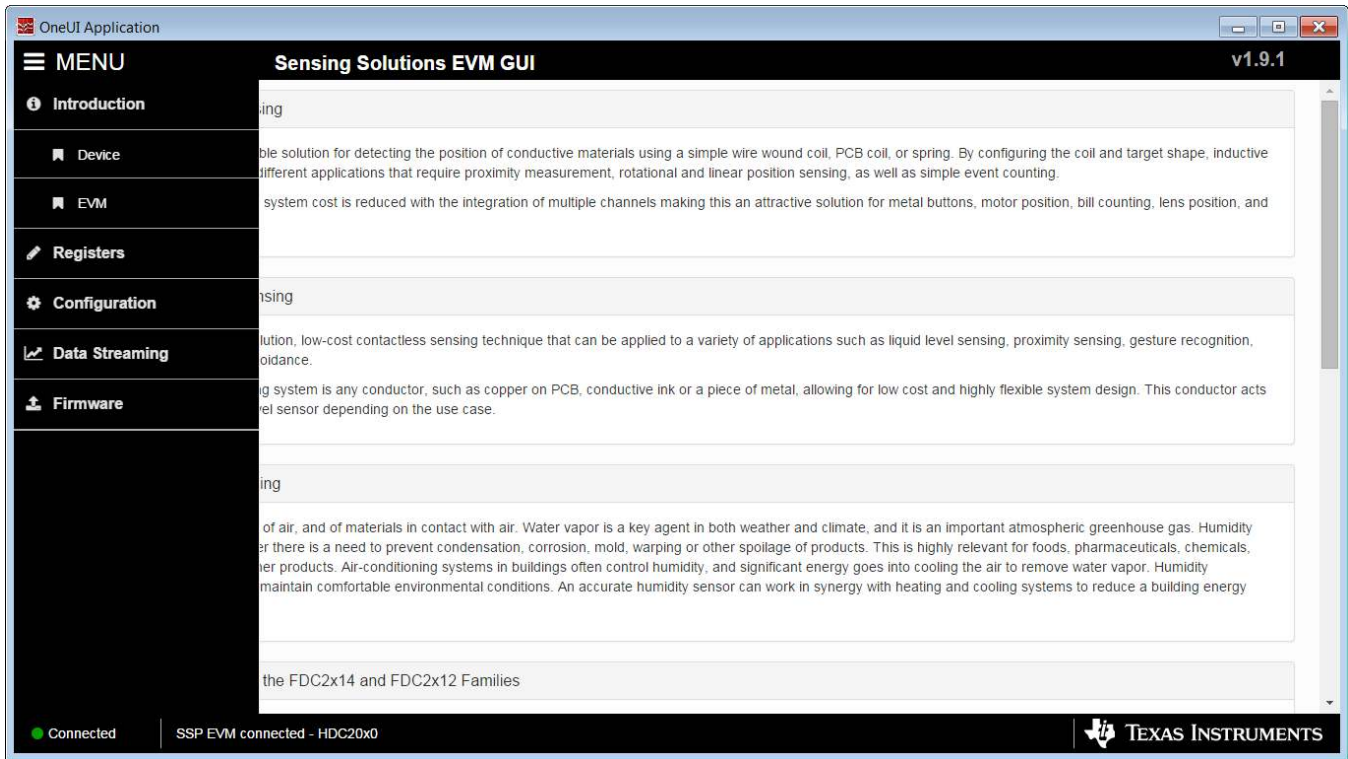

Figure 20. GUI Navigation Menu

3.4 Configuring the Device Using Register Page

The register page allows users to control the device directly with the register values. The user may also use this page to read the current register values on the device.

3.4.1 Automatically Updating GUI Register Values Using Auto-Read

Autoread will periodically request the register values on the device. Click the dropdown box next to “Auto Read” to select the update interval.

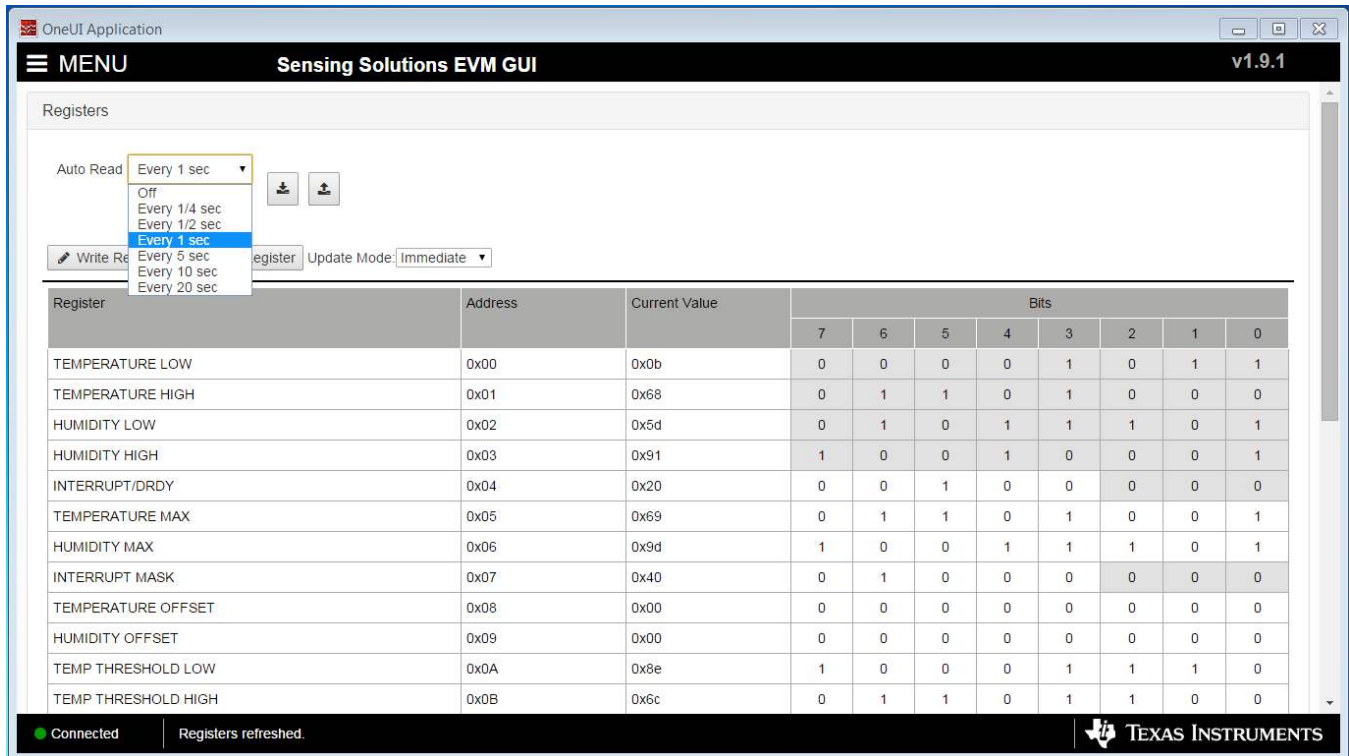

Figure 21. Selecting Auto-Read Interval on Register Page

3.4.2 Manually Updating Device Register Values

There are two methods to change register values: update the entire register value or change a single bit within the register. The recommended update mode is always “Immediate” and not “Deferred”. To update register values, follow these steps.

1. Double-click the current value of the register that needs to be changed. The text will turn into an editable text box

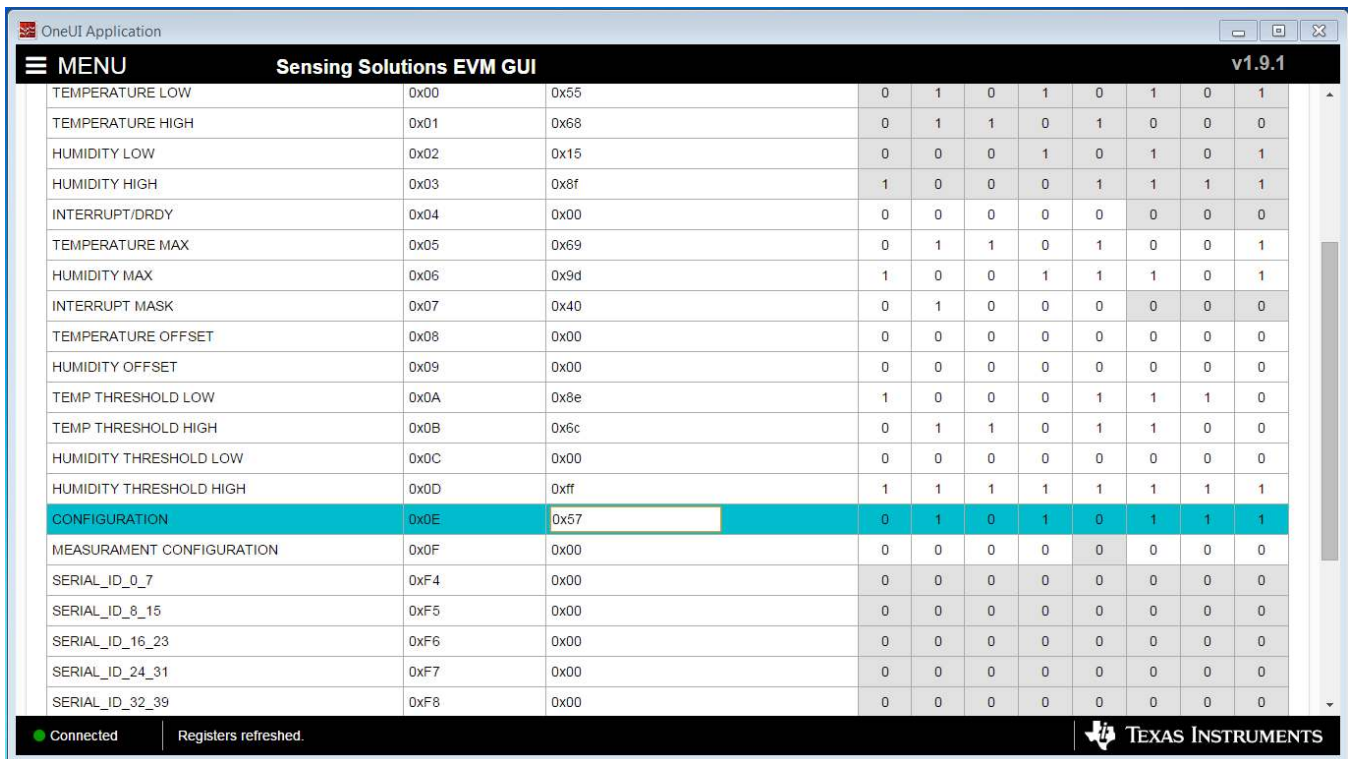

Figure 22. Selecting a Register's Current Value for Editing on Register Page

2. Type the new value in hexadecimal into the box and click enter. The text box changes to normal text and the GUI will send a command to the EVM to update the device register

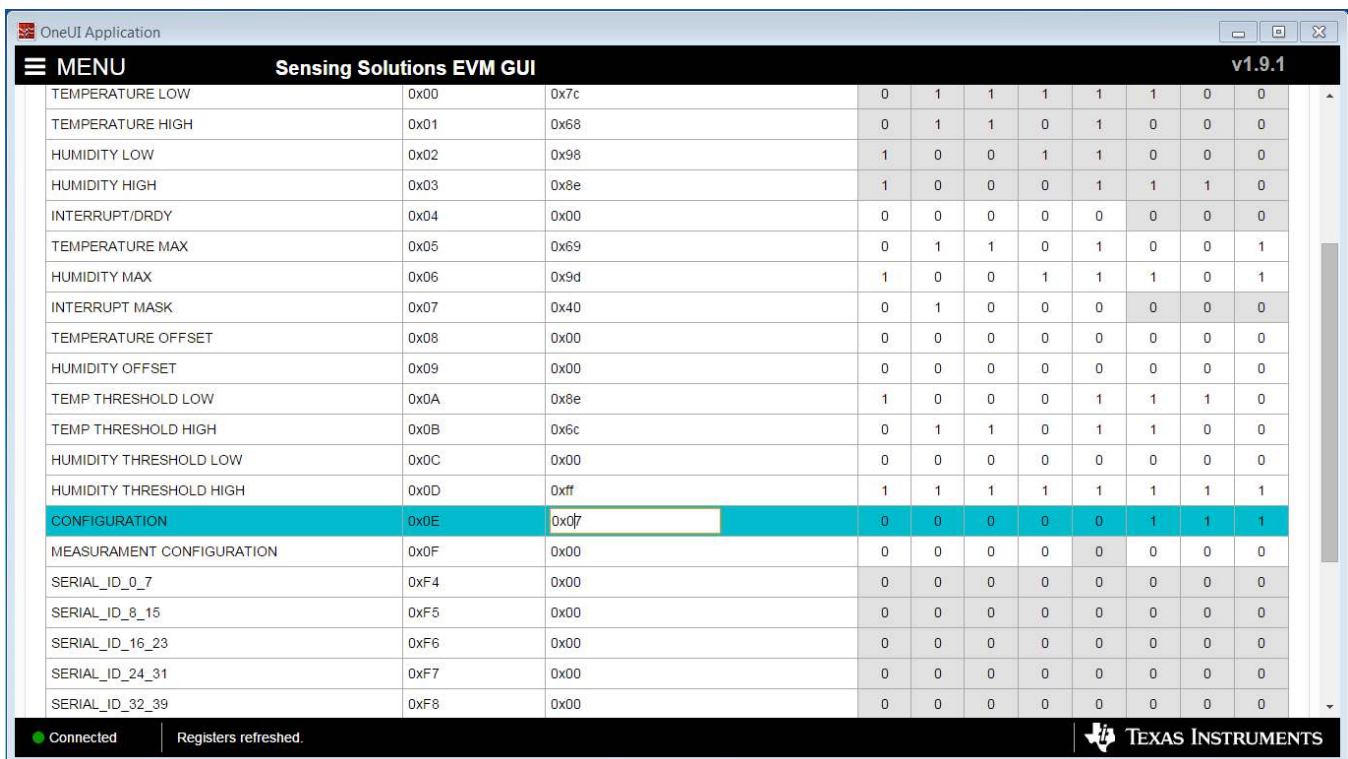
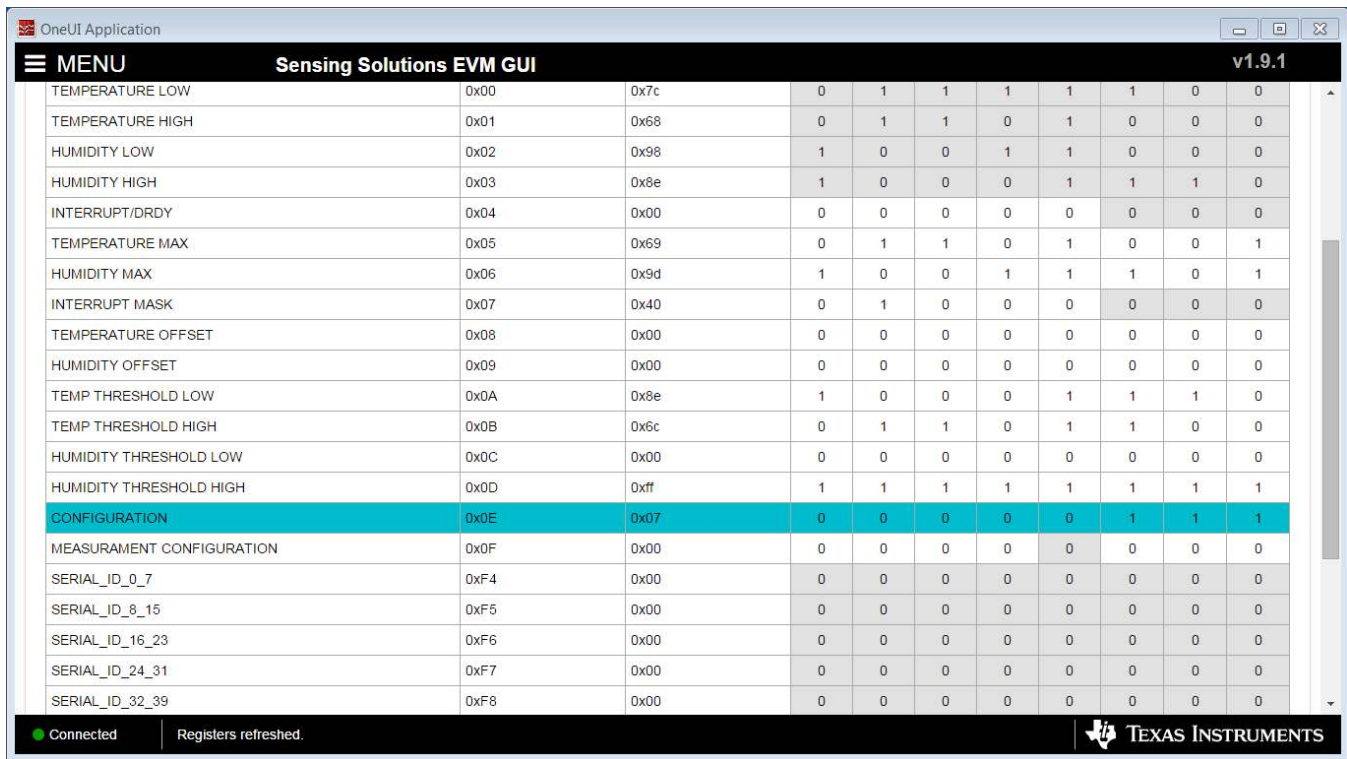

Figure 23. Entering New Value for Register on Register Page



MENU		Sensing Solutions EVM GUI								v1.9.1	
TEMPERATURE LOW	0x00	0x7c	0	1	1	1	1	1	0	0	
TEMPERATURE HIGH	0x01	0x68	0	1	1	0	1	0	0	0	
HUMIDITY LOW	0x02	0x98	1	0	0	1	1	0	0	0	
HUMIDITY HIGH	0x03	0x8e	1	0	0	0	1	1	1	0	
INTERRUPT/DRDY	0x04	0x00	0	0	0	0	0	0	0	0	
TEMPERATURE MAX	0x05	0x69	0	1	1	0	1	0	0	1	
HUMIDITY MAX	0x06	0x9d	1	0	0	1	1	1	0	1	
INTERRUPT MASK	0x07	0x40	0	1	0	0	0	0	0	0	
TEMPERATURE OFFSET	0x08	0x00	0	0	0	0	0	0	0	0	
HUMIDITY OFFSET	0x09	0x00	0	0	0	0	0	0	0	0	
TEMP THRESHOLD LOW	0x0A	0x8e	1	0	0	0	1	1	1	0	
TEMP THRESHOLD HIGH	0x0B	0x6c	0	1	1	0	1	1	0	0	
HUMIDITY THRESHOLD LOW	0x0C	0x00	0	0	0	0	0	0	0	0	
HUMIDITY THRESHOLD HIGH	0x0D	0xff	1	1	1	1	1	1	1	1	
CONFIGURATION	0x0E	0x07	0	0	0	0	0	1	1	1	
MEASUREMENT CONFIGURATION	0x0F	0x00	0	0	0	0	0	0	0	0	
SERIAL_ID_0_7	0xF4	0x00	0	0	0	0	0	0	0	0	
SERIAL_ID_8_15	0xF5	0x00	0	0	0	0	0	0	0	0	
SERIAL_ID_16_23	0xF6	0x00	0	0	0	0	0	0	0	0	
SERIAL_ID_24_31	0xF7	0x00	0	0	0	0	0	0	0	0	
SERIAL_ID_32_39	0xF8	0x00	0	0	0	0	0	0	0	0	

● Connected Registers refreshed. 

Figure 24. Register Value Updated After Changing Value on Register Page

To change individual bit values rather than entire register values follow these steps.

1. Hover the mouse over the desired bit to change

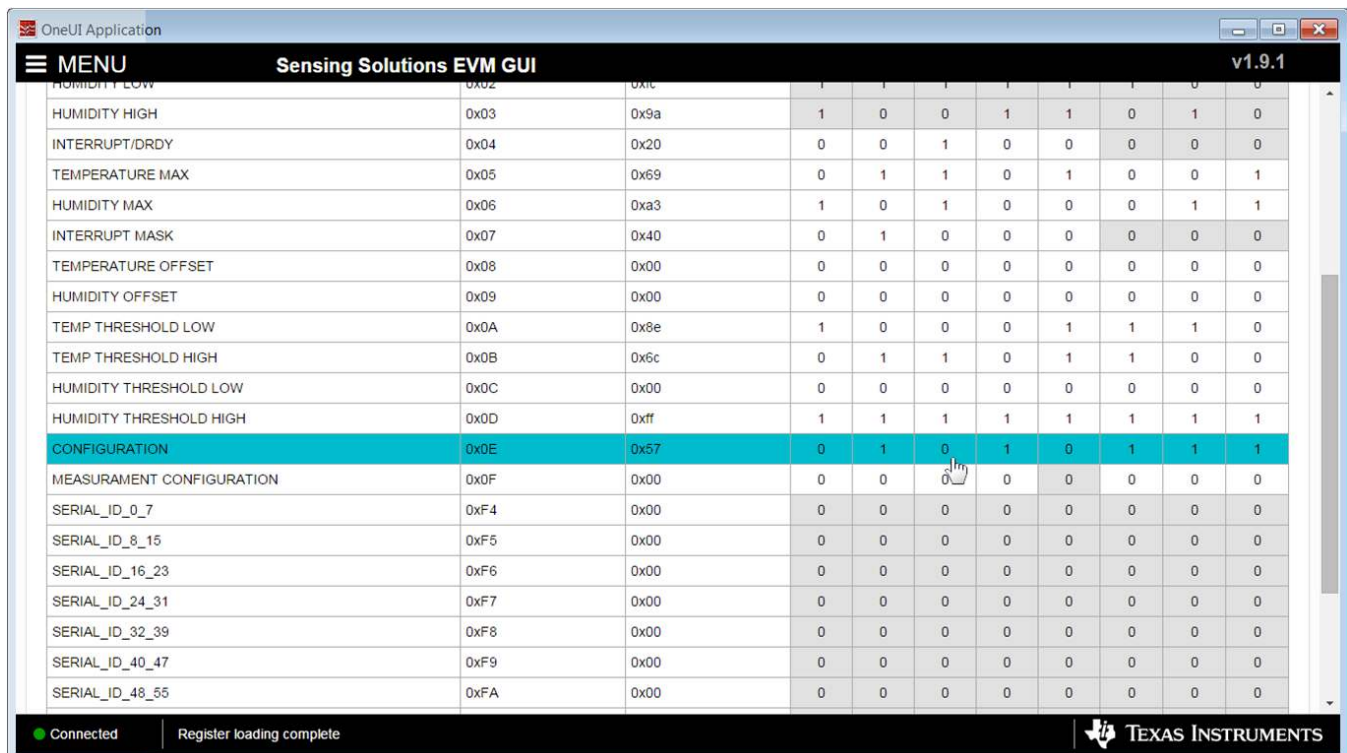

MENU		Sensing Solutions EVM GUI								v1.9.1	
HUMIDITY LOW	0x02	0x98	1	0	0	1	1	0	0	0	
HUMIDITY HIGH	0x03	0x9a	1	0	0	1	1	0	1	0	
INTERRUPT/DRDY	0x04	0x20	0	0	1	0	0	0	0	0	
TEMPERATURE MAX	0x05	0x69	0	1	1	0	1	0	0	1	
HUMIDITY MAX	0x06	0xa3	1	0	1	0	0	0	1	1	
INTERRUPT MASK	0x07	0x40	0	1	0	0	0	0	0	0	
TEMPERATURE OFFSET	0x08	0x00	0	0	0	0	0	0	0	0	
HUMIDITY OFFSET	0x09	0x00	0	0	0	0	0	0	0	0	
TEMP THRESHOLD LOW	0x0A	0x8e	1	0	0	0	1	1	1	0	
TEMP THRESHOLD HIGH	0x0B	0x6c	0	1	1	0	1	1	0	0	
HUMIDITY THRESHOLD LOW	0x0C	0x00	0	0	0	0	0	0	0	0	
HUMIDITY THRESHOLD HIGH	0x0D	0xff	1	1	1	1	1	1	1	1	
CONFIGURATION	0x0E	0x57	0	1	0	1	0	1	1	1	
MEASUREMENT CONFIGURATION	0x0F	0x00	0	0	0	0	0	0	0	0	
SERIAL_ID_0_7	0xF4	0x00	0	0	0	0	0	0	0	0	
SERIAL_ID_8_15	0xF5	0x00	0	0	0	0	0	0	0	0	
SERIAL_ID_16_23	0xF6	0x00	0	0	0	0	0	0	0	0	
SERIAL_ID_24_31	0xF7	0x00	0	0	0	0	0	0	0	0	
SERIAL_ID_32_39	0xF8	0x00	0	0	0	0	0	0	0	0	
SERIAL_ID_40_47	0xF9	0x00	0	0	0	0	0	0	0	0	
SERIAL_ID_48_55	0xFA	0x00	0	0	0	0	0	0	0	0	

● Connected Register loading complete 

Figure 25. Hovering Mouse Over Register Bit Value on Register Page

2. Double-click the bit to toggle its value and the register's current value will update automatically

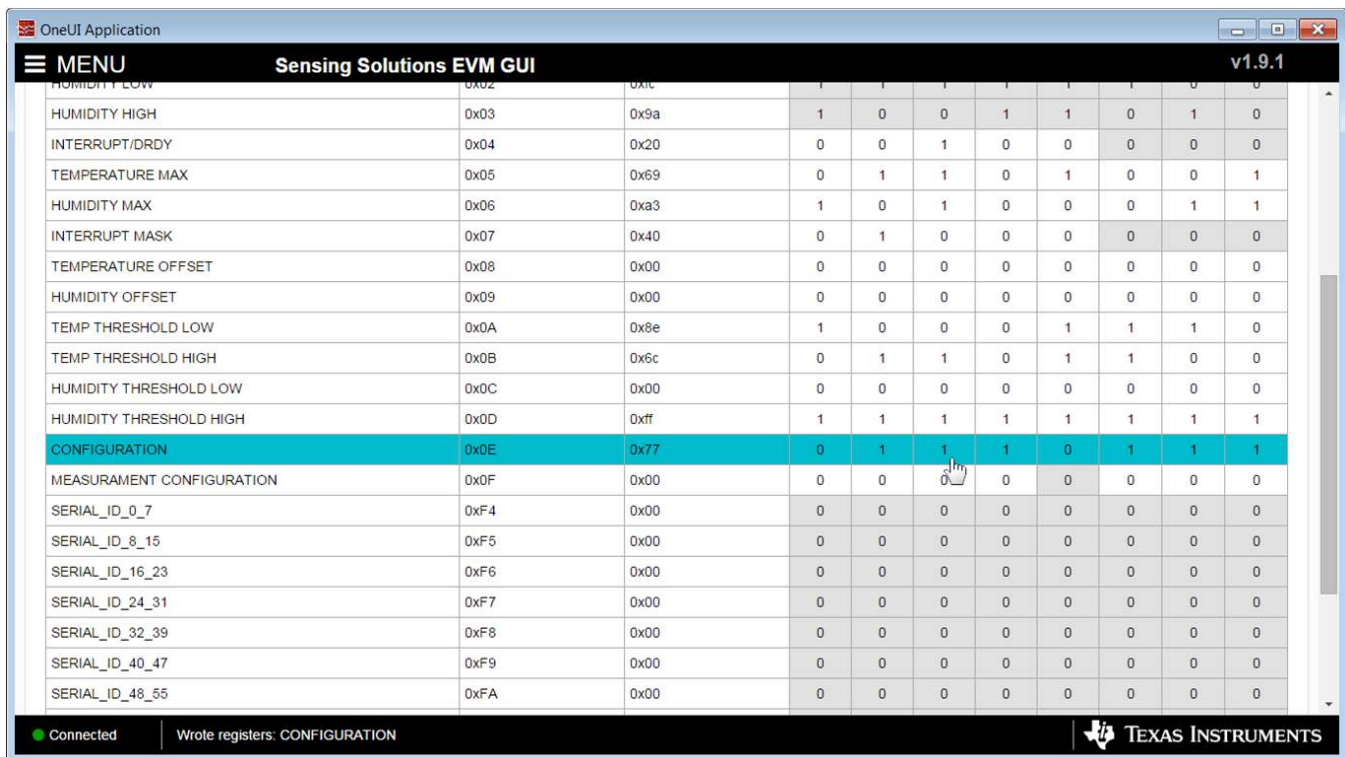

The screenshot shows a software application window titled "OneUI Application" with a menu icon and the text "Sensing Solutions EVM GUI v1.9.1". The main content is a table of registers. The "CONFIGURATION" row is highlighted in blue, and a mouse cursor is hovering over the bit value '1' in the 6th column of that row. The status bar at the bottom shows "Connected" and "Wrote registers: CONFIGURATION".

Register Name	Address	Value	Bit 0	Bit 1	Bit 2	Bit 3	Bit 4	Bit 5	Bit 6	Bit 7	Bit 8	Bit 9
HUMIDITY LOW	0x02	0xc	1	0	0	1	1	0	1	0	0	0
HUMIDITY HIGH	0x03	0x9a	1	0	0	1	1	0	1	0	0	0
INTERRUPT/DRDY	0x04	0x20	0	0	1	0	0	0	0	0	0	0
TEMPERATURE MAX	0x05	0x69	0	1	1	0	1	0	0	0	0	1
HUMIDITY MAX	0x06	0xa3	1	0	1	0	0	0	0	1	1	1
INTERRUPT MASK	0x07	0x40	0	1	0	0	0	0	0	0	0	0
TEMPERATURE OFFSET	0x08	0x00	0	0	0	0	0	0	0	0	0	0
HUMIDITY OFFSET	0x09	0x00	0	0	0	0	0	0	0	0	0	0
TEMP THRESHOLD LOW	0x0A	0x8e	1	0	0	0	1	1	1	1	0	0
TEMP THRESHOLD HIGH	0x0B	0x6c	0	1	1	0	1	1	0	0	0	0
HUMIDITY THRESHOLD LOW	0x0C	0x00	0	0	0	0	0	0	0	0	0	0
HUMIDITY THRESHOLD HIGH	0x0D	0xff	1	1	1	1	1	1	1	1	1	1
CONFIGURATION	0x0E	0x77	0	1	1	1	0	1	1	1	1	1
MEASUREMENT CONFIGURATION	0x0F	0x00	0	0	0	0	0	0	0	0	0	0
SERIAL_ID_0_7	0xF4	0x00	0	0	0	0	0	0	0	0	0	0
SERIAL_ID_8_15	0xF5	0x00	0	0	0	0	0	0	0	0	0	0
SERIAL_ID_16_23	0xF6	0x00	0	0	0	0	0	0	0	0	0	0
SERIAL_ID_24_31	0xF7	0x00	0	0	0	0	0	0	0	0	0	0
SERIAL_ID_32_39	0xF8	0x00	0	0	0	0	0	0	0	0	0	0
SERIAL_ID_40_47	0xF9	0x00	0	0	0	0	0	0	0	0	0	0
SERIAL_ID_48_55	0xFA	0x00	0	0	0	0	0	0	0	0	0	0

Figure 26. Toggling Register Bit Value on Register Page

3.4.3 Reading Register Values without Auto-Read

To read register values follow these steps.

1. Select the register to update by clicking any column of the register row in the table

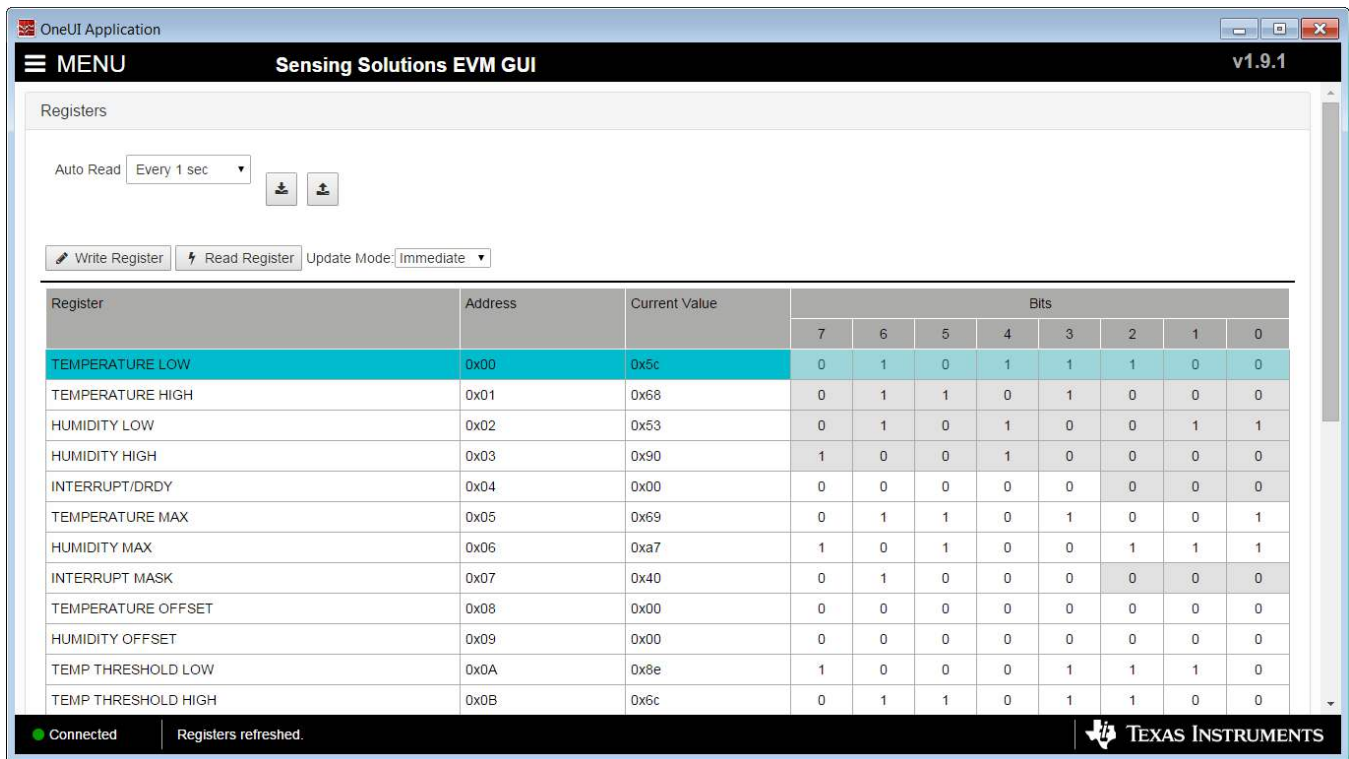

Figure 27. Selecting a Register on Register Page

2. Click the “Read Register” button to update the selected register’s current value and bit values in the table

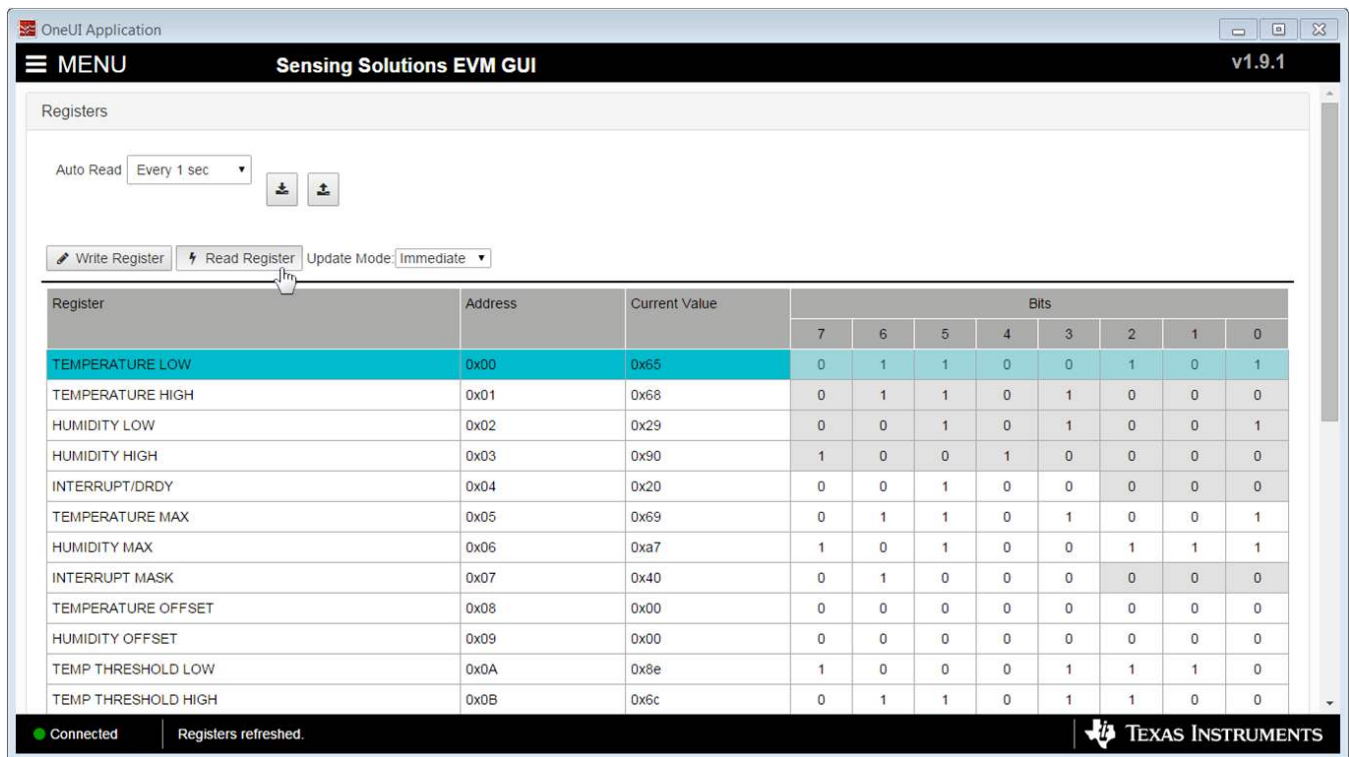

Figure 28. Reading the Current Device Register Value on Register Page

3.4.4 Saving Device Configuration

To save the current register settings of the device follow these steps.

1. Click the button immediately right to the “Auto-Read” selection dropdown

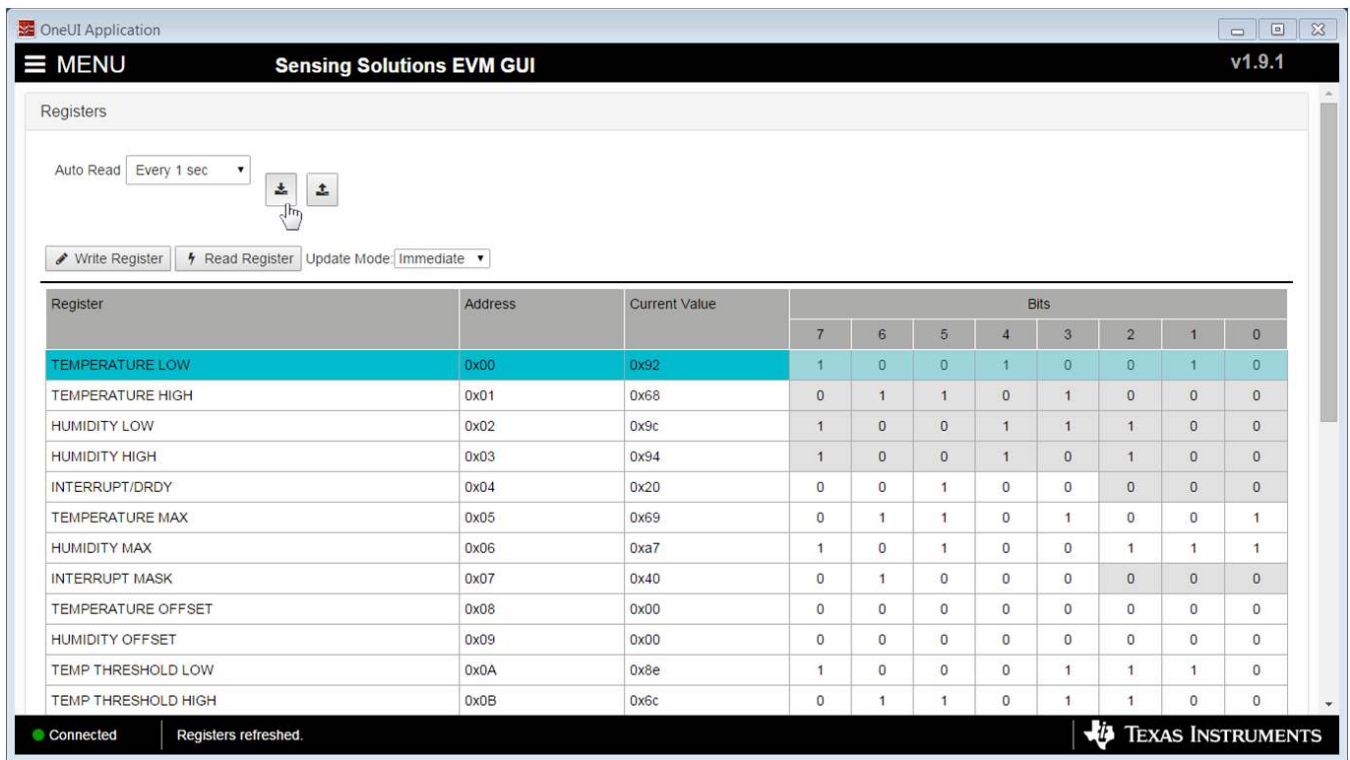

Figure 29. Save Register Values to File on Register Page

2. Choose a JSON file name and the directory to save it within. Then click “Save”

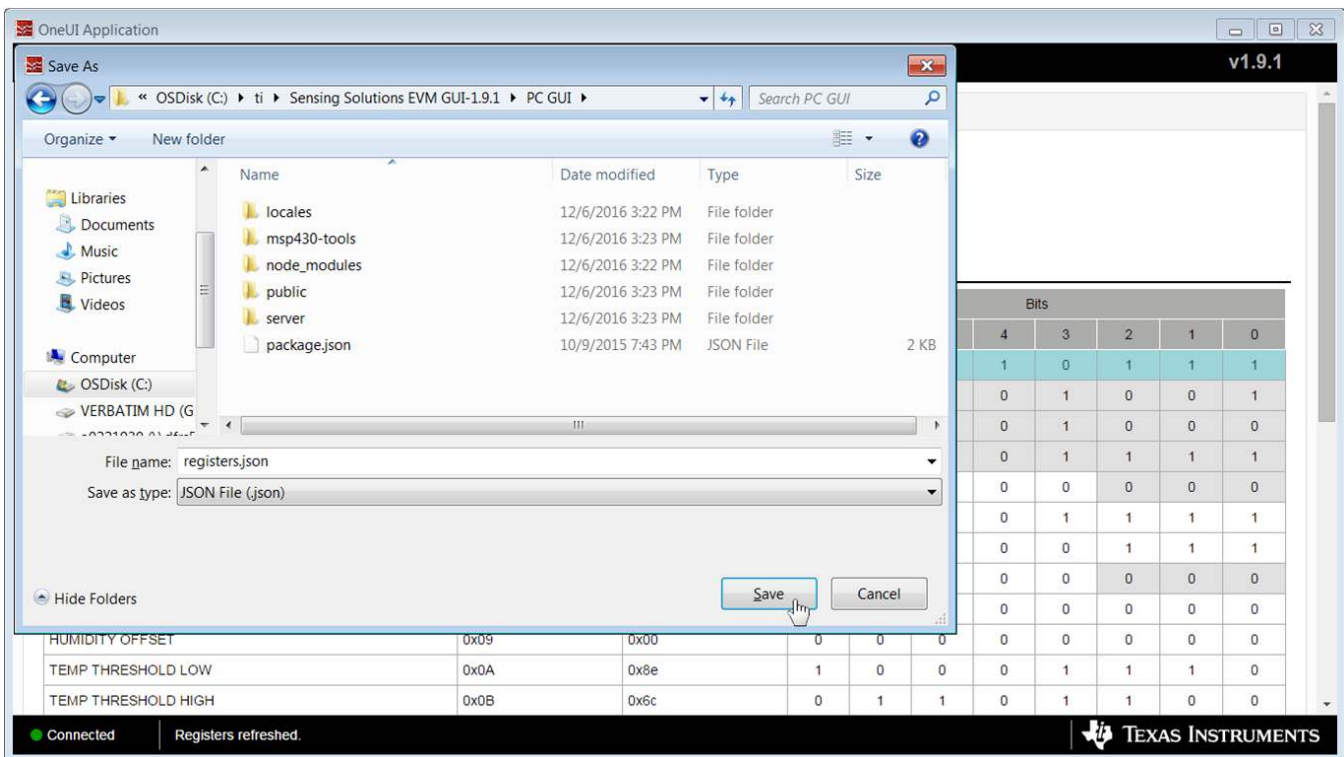

Figure 30. Choosing a JSON File Name to Save Register Values

3.4.5 Loading Previously Saved Device Configuration

To load previously saved register settings from a JSON file follow these steps.

1. Click the button furthest right from the “Auto-Read” selection dropdown

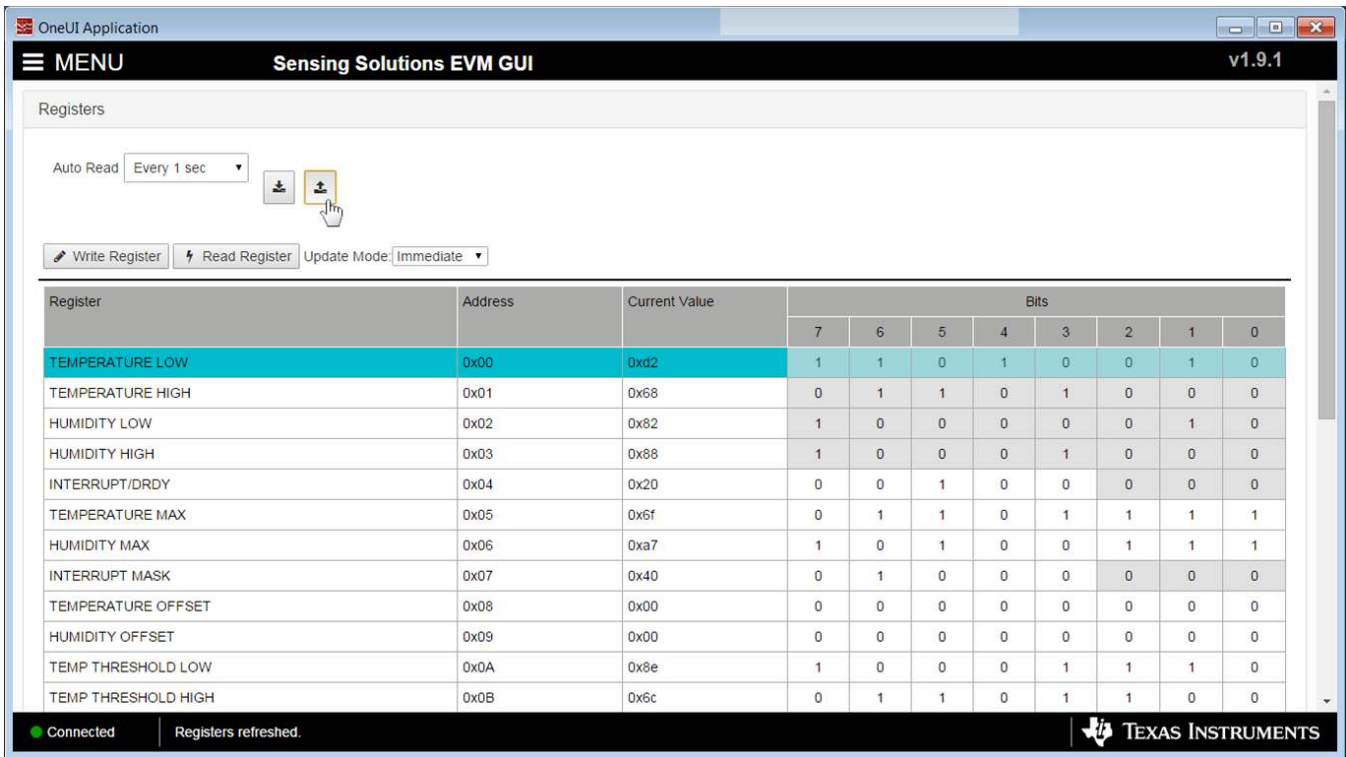

Figure 31. Loading Previously Saved Register Values from File on Register Page

2. Select the JSON file with the desired settings and click “Open”

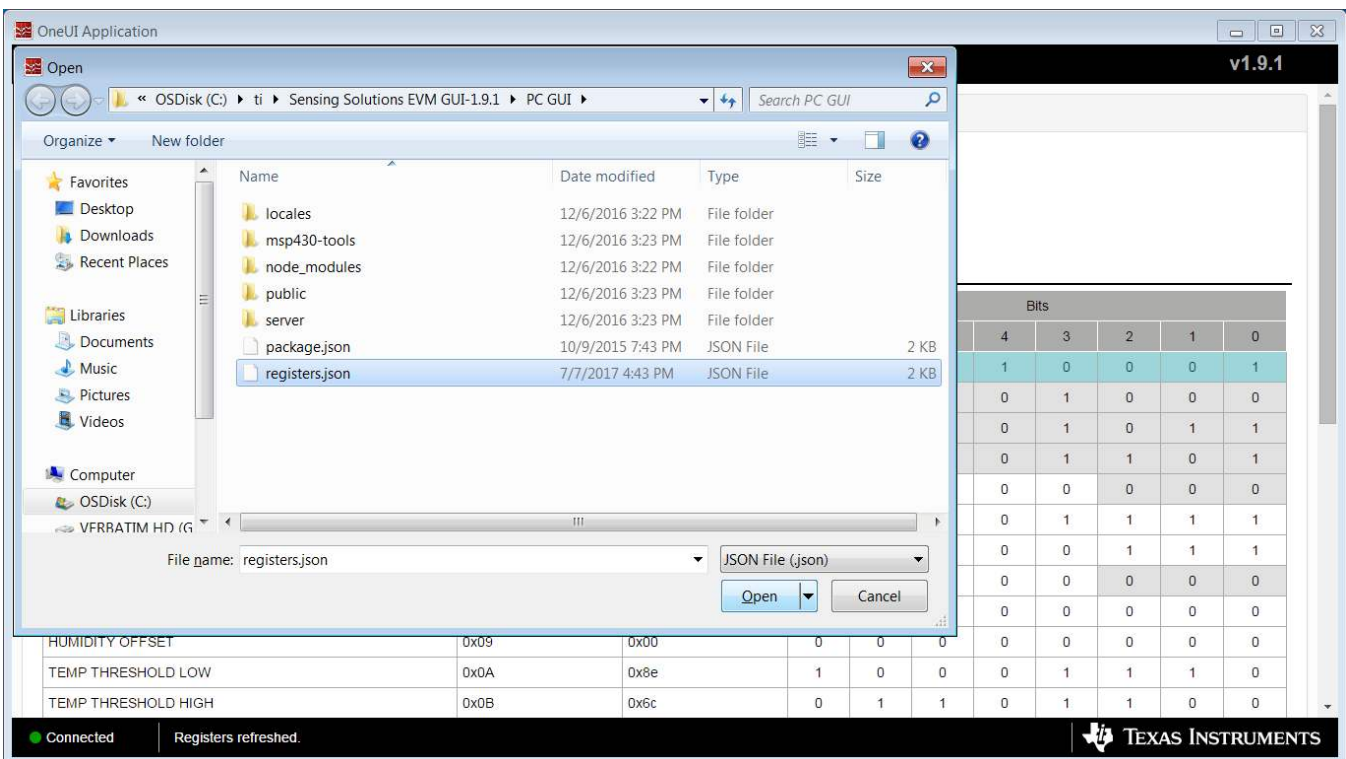

Figure 32. Selecting Previously Save Register Value JSON File

3.5 Configuring the Device using Configuration Page

The Sensing Solutions GUI is capable on configuring the device more intuitively than the direct register values. For more information about configuring the HDC2010 please reference the device datasheet.

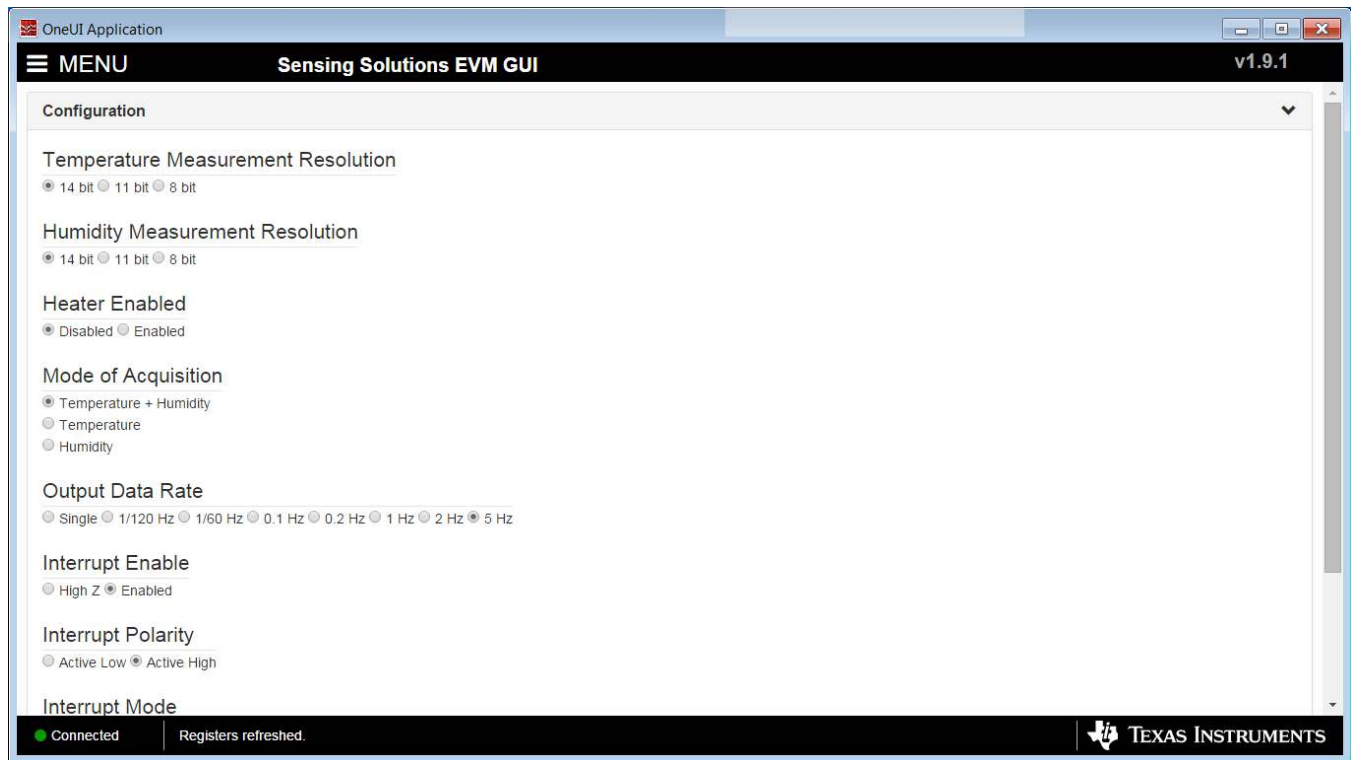

Figure 33. HDC2010 GUI Configuration Page

3.6 Streaming Measurement Data

The Sensing Solutions GUI and EVM provide a tool to capture measurement data at rates up to 500Hz. The section describes how to use the data measurement tools from the "Data Streaming" page accessible from the GUI menu.

3.6.1 Choosing Graph Units and Visible Channels

Select the drop down menu on top of the y-axis to choose the units of the graph. Available options include: Temperature and Humidity, and Raw Code.



Figure 34. Selecting the Measurement Units for the Data Streaming Graph

To select which measurements are displayed in the graph, check or uncheck the temperature and relative humidity boxes shown next to the graph units. Selecting or not selecting the data types only affects the graph and not the data logged to a file. If a data type is not enabled in the Configuration page it will not appear on the Data Streaming page.

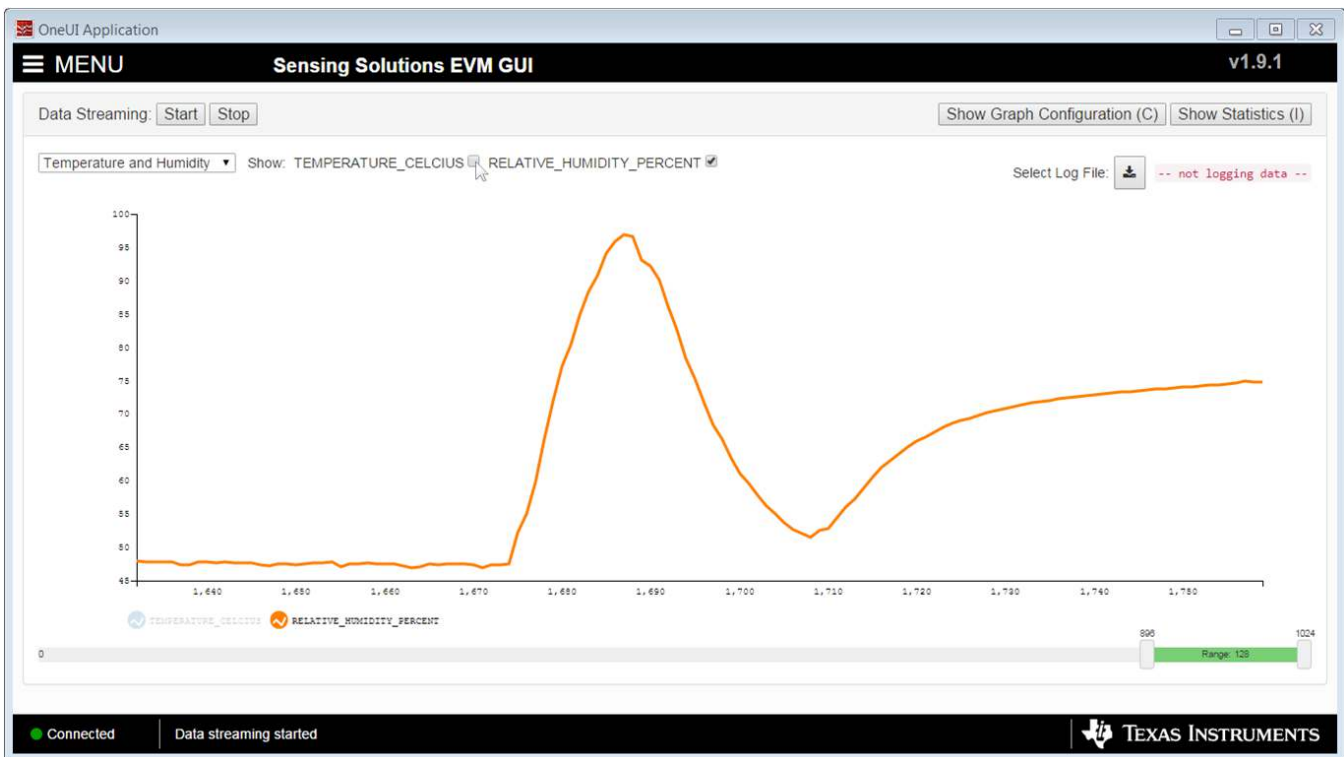

Figure 35. Data Streaming Graph Showing Only Relative Humidity Percent

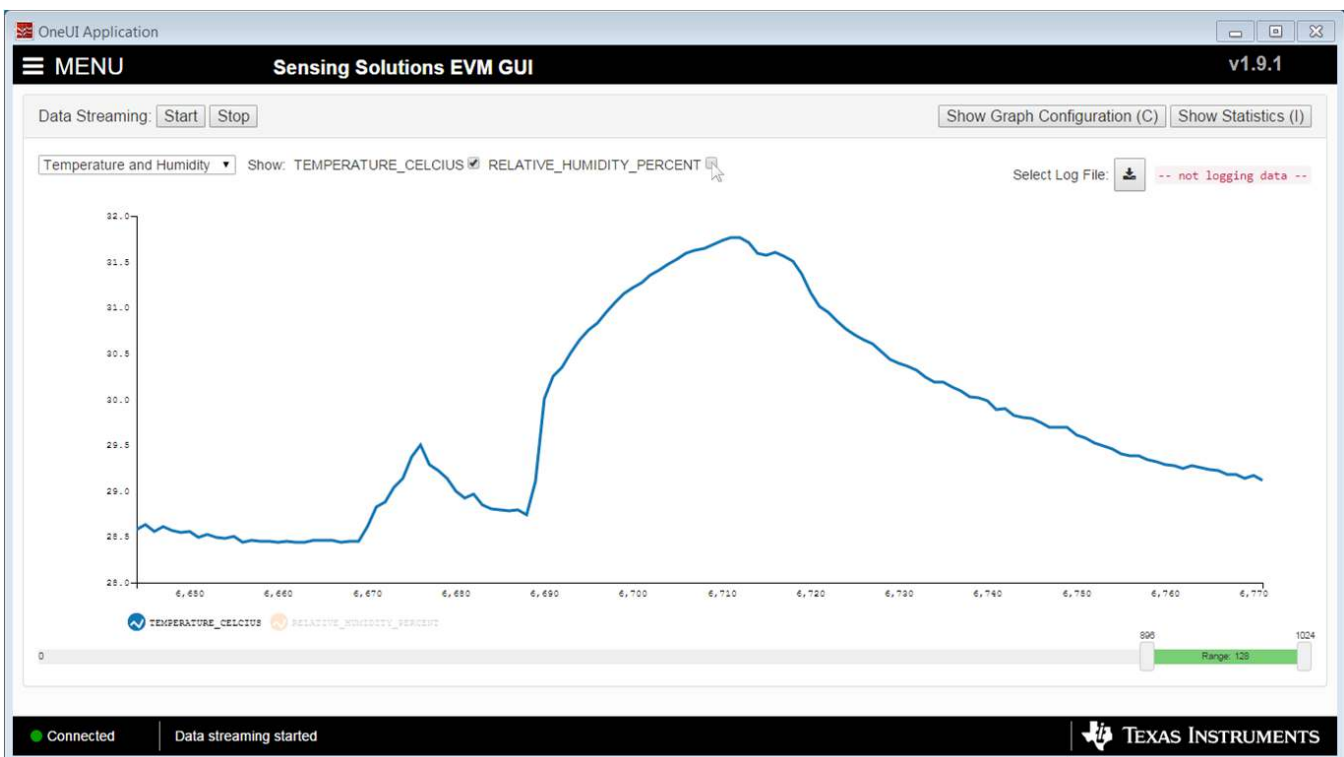

Figure 36. Data Streaming Graph Showing Only Temperature

3.6.2 Logging Data to a File

Follow these steps to log measurement data to a file.

1. Click the button in the upper right under next to "Click to Select Log File"

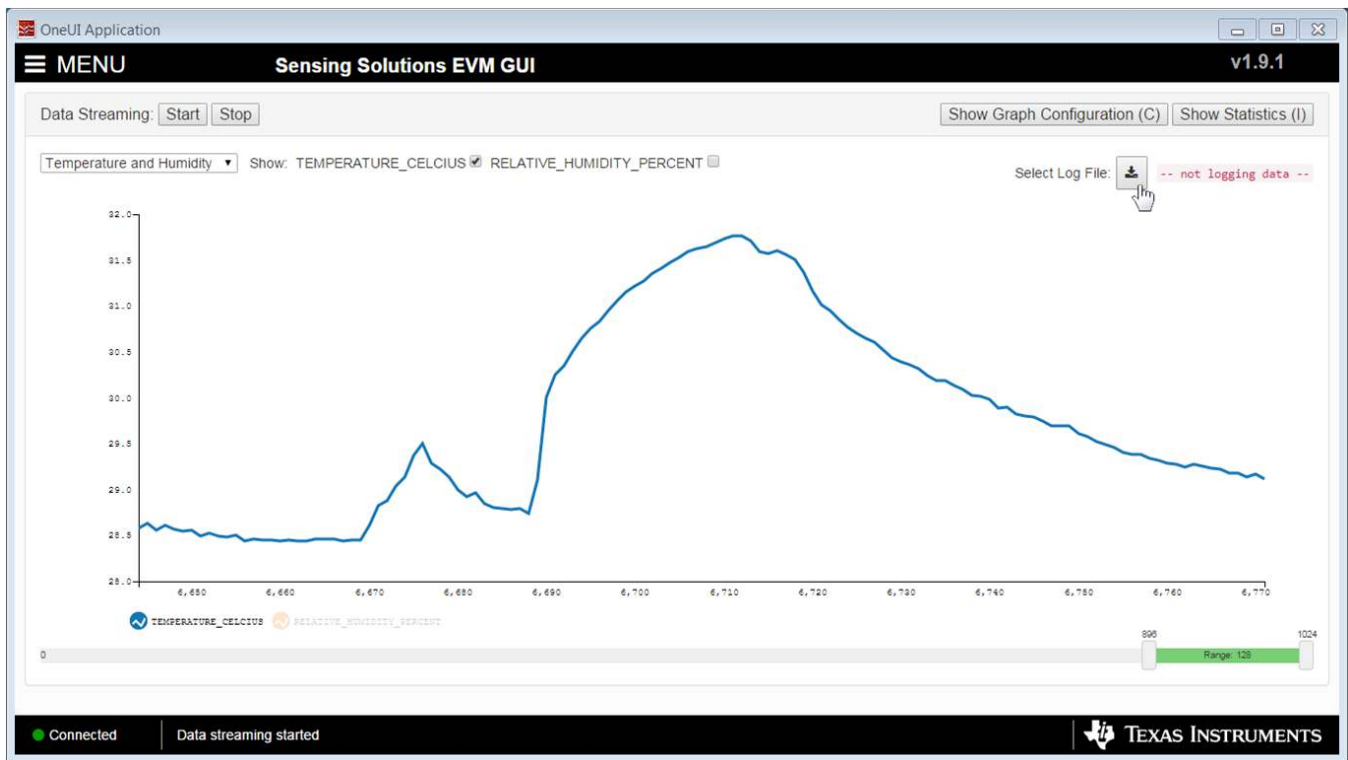

Figure 37. Select Log File Button on Data Streaming Page

2. Select a file name and directory to save the data to and then click the “Save” button

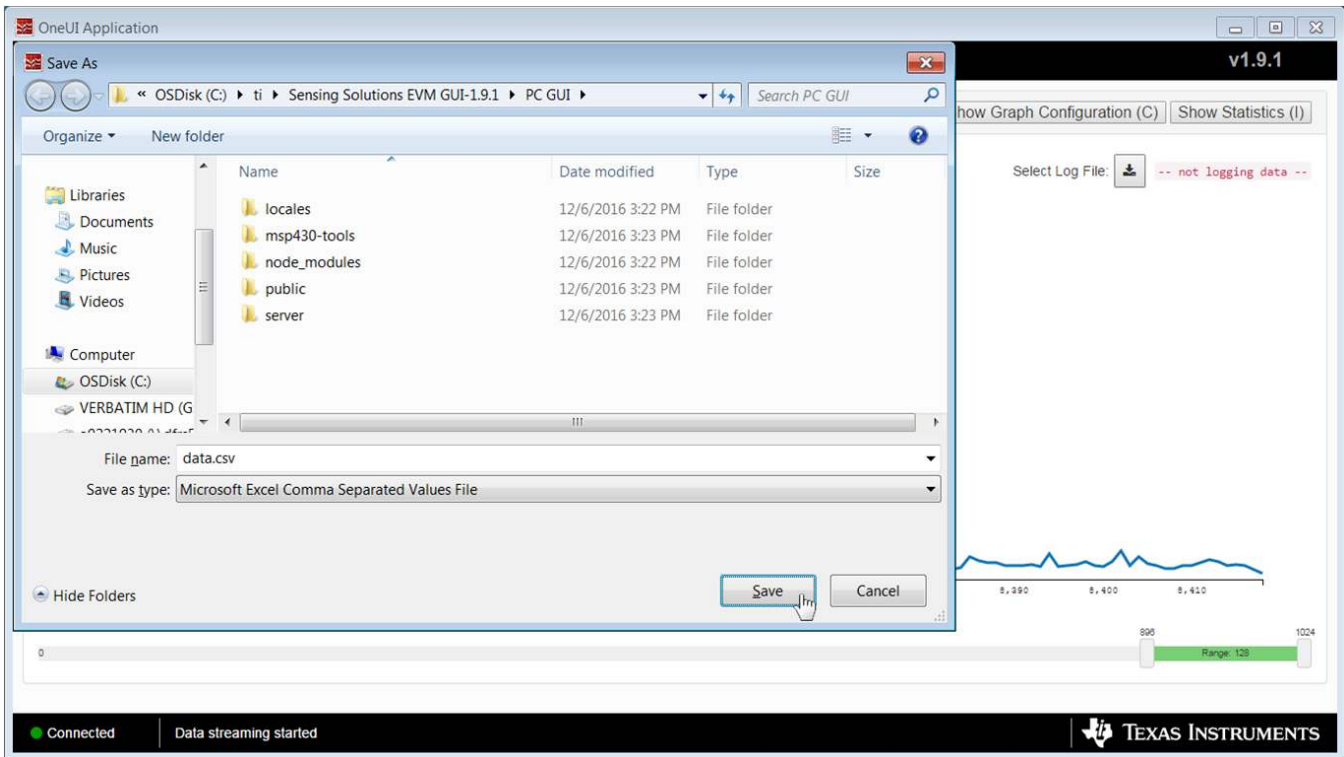

Figure 38. Selecting the Log File for Data Streaming

3.6.3 Setting the Vertical Axis Scale and Sampling Rate

To set the vertical axis scale or change the sampling rate follow these steps.

1. Click the “Show Graph Configuration” button

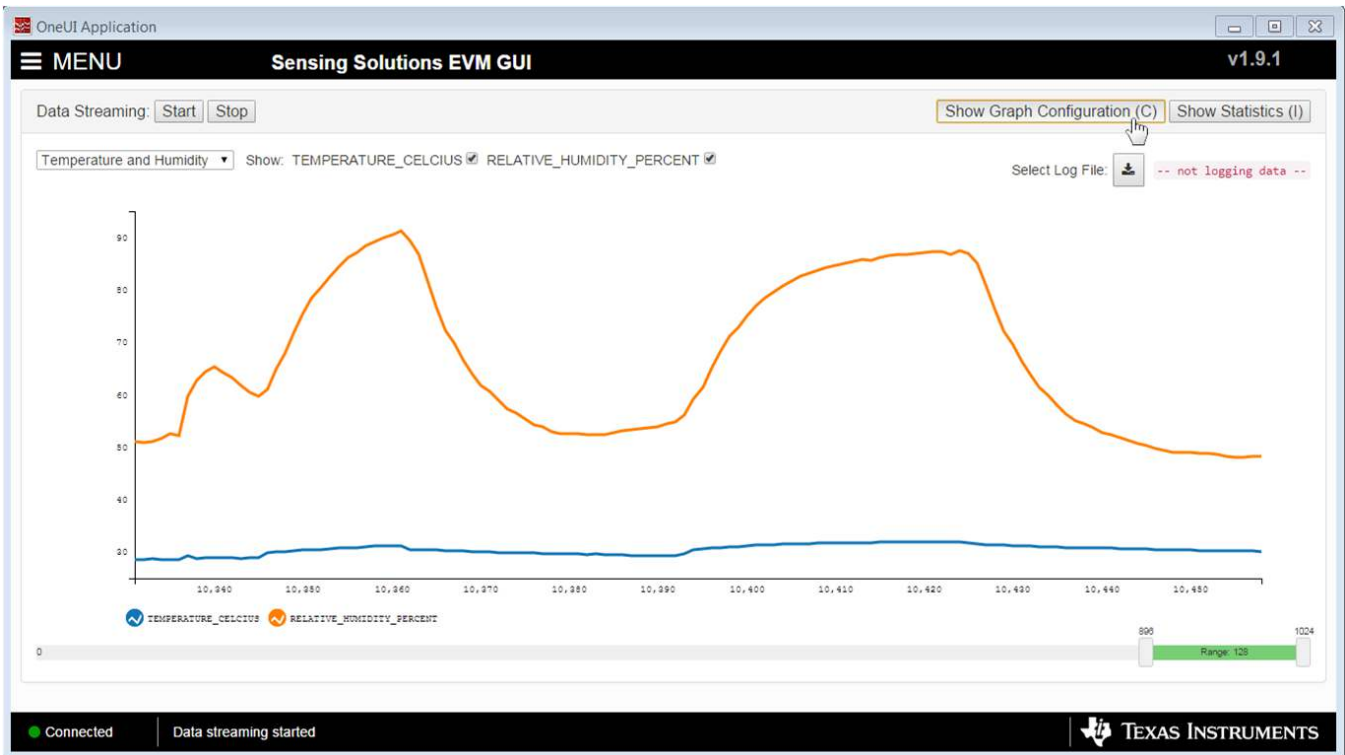

Figure 39. Show Graph Configuration Button on Data Streaming Page

2. The sampling rate can be adjusted in the “Sampling Rate” table.
 - Note that the GUI sampling rate affects only the graph and logging rate but not the actual device sampling rate

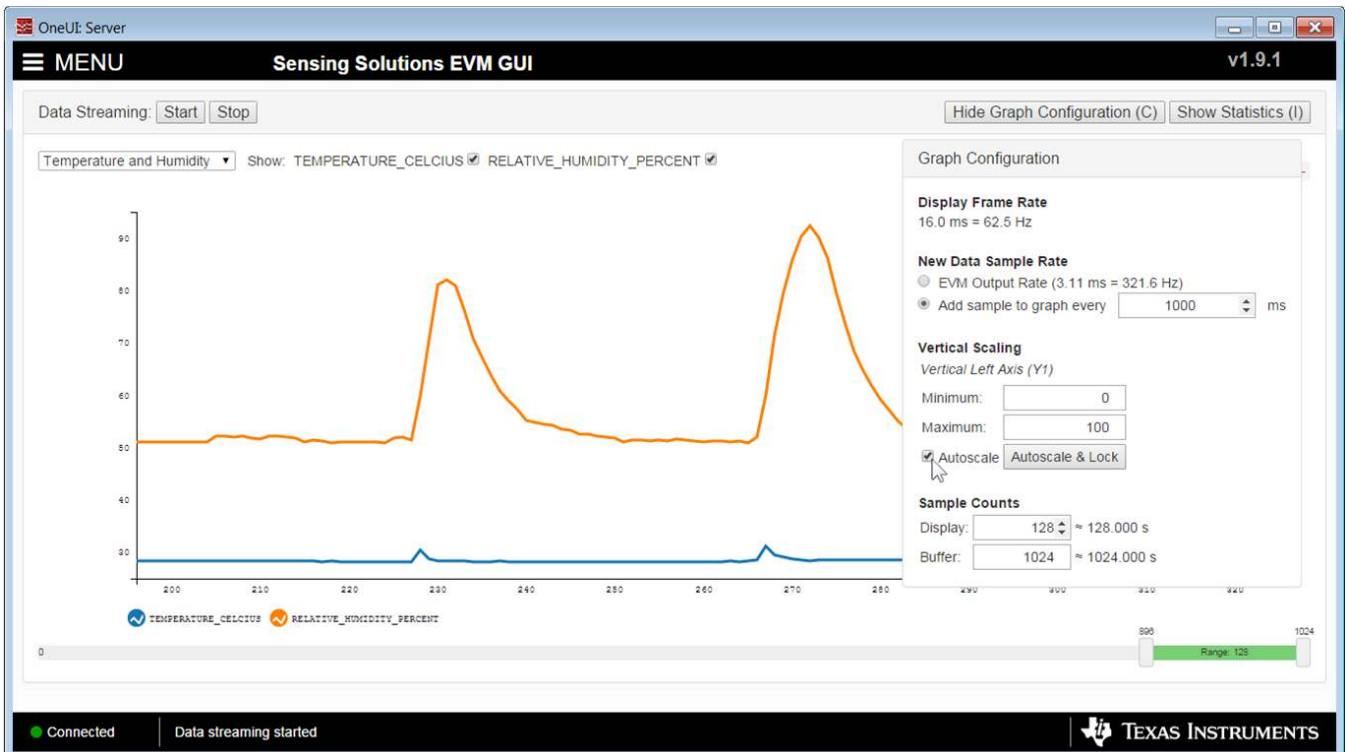

Figure 40. Setting the Data Streaming Sample Rate to 1 Second

- The vertical scaling can be automatically updated or manually controlled by selecting either checkbox in the “Vertical Scaling” table.

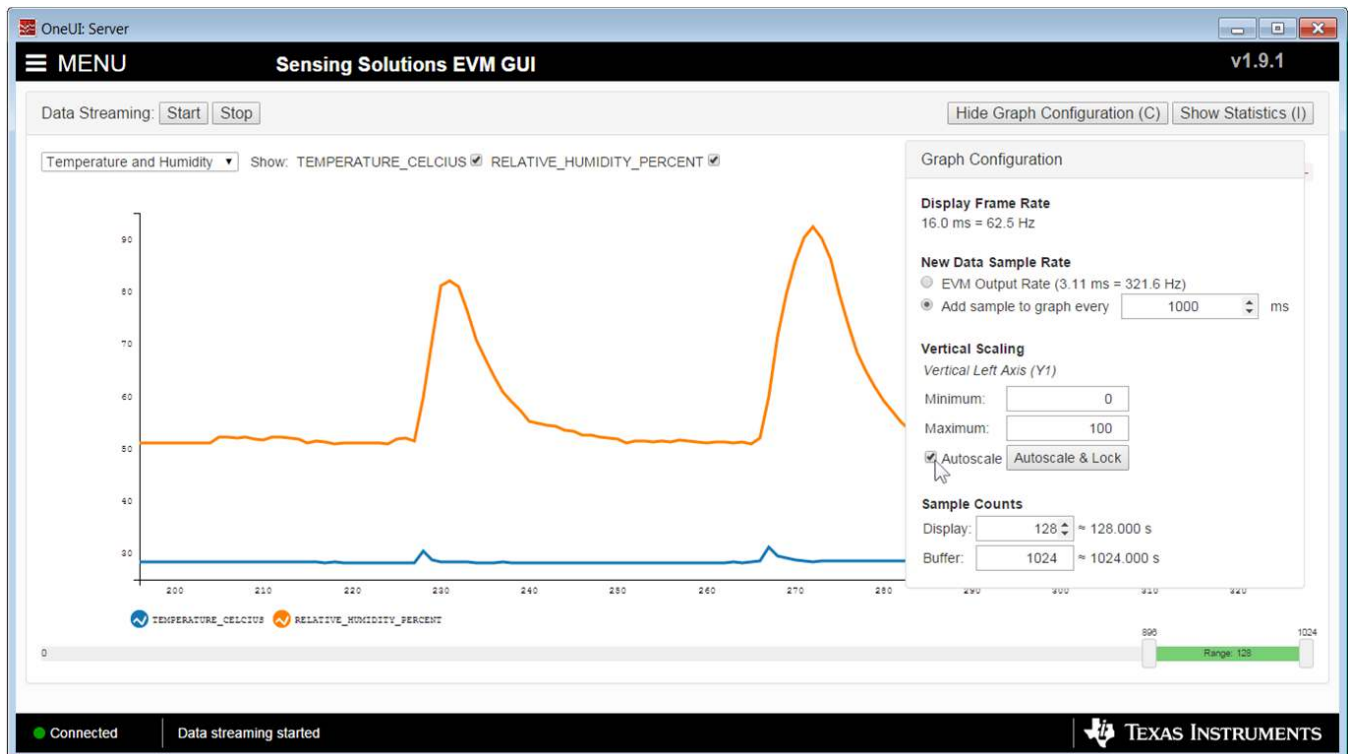

Figure 41. Manually Setting the Vertical Scale on Data Streaming Graph

3.6.4 Starting and Stopping Measurement Data Acquisition

To start data streaming click the “Start” button.



Figure 42. Starting Data Acquisition on Data Streaming Graph

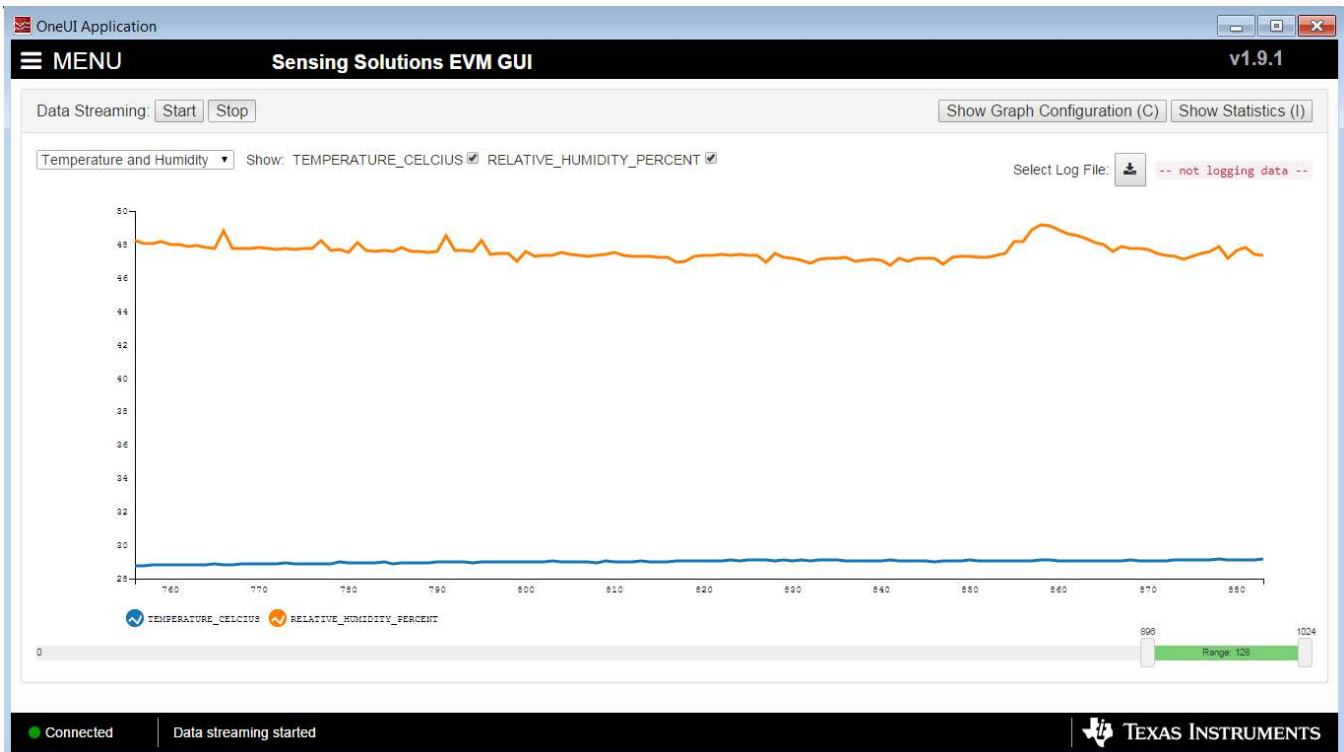

Figure 43. Data Acquisition In Progress on Data Streaming Page

To stop data streaming click the “Stop” button.

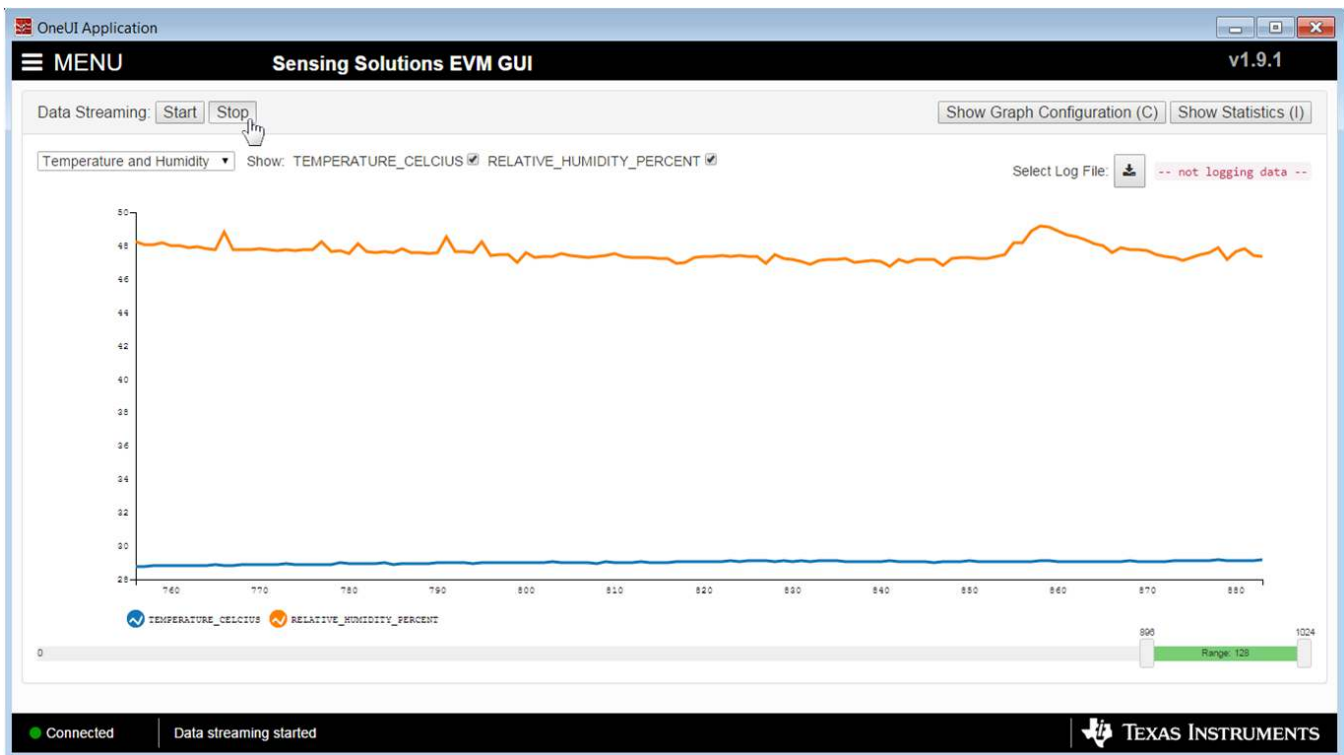

Figure 44. Stopping Data Acquisition on Data Streaming Graph

3.6.5 Displaying Measurement Data Statistics

Click the “Show Statistics” button to view the measurement statistics.

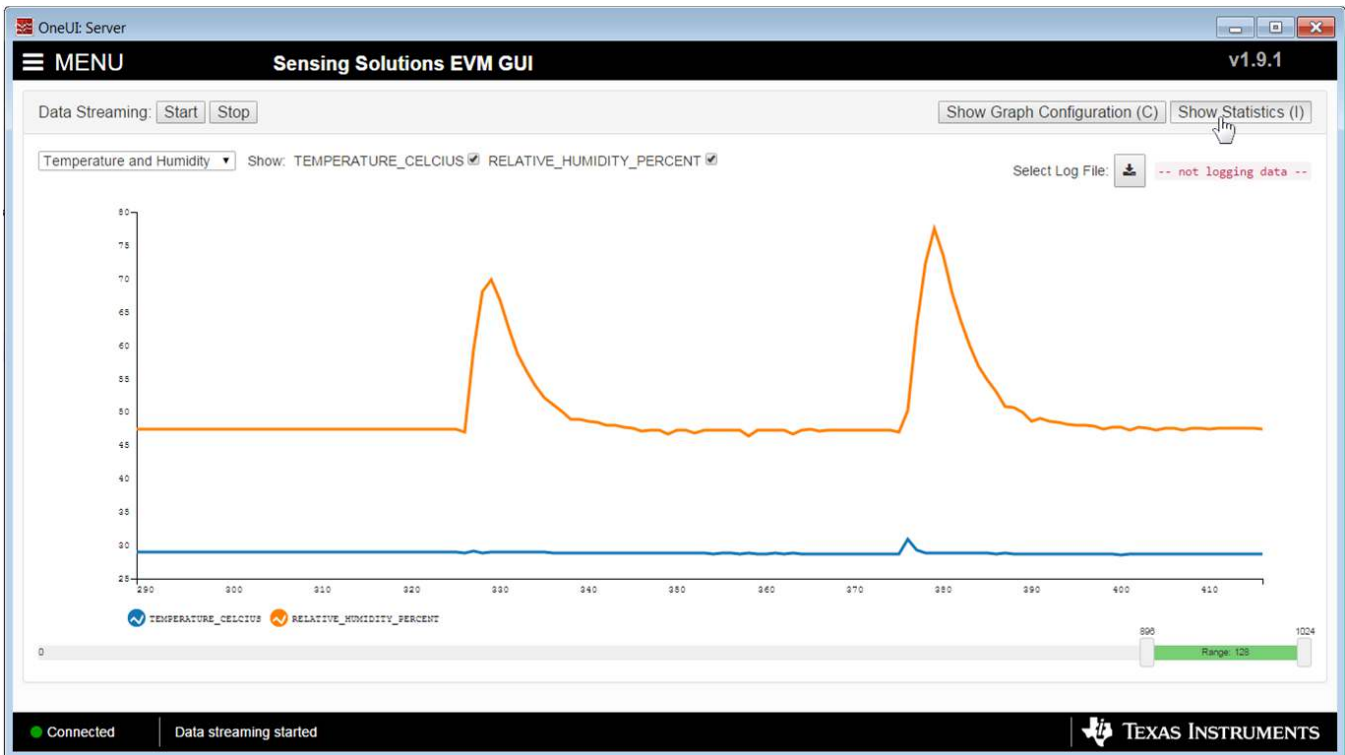

Figure 45. Show Statistics Button on Data Streaming Graph

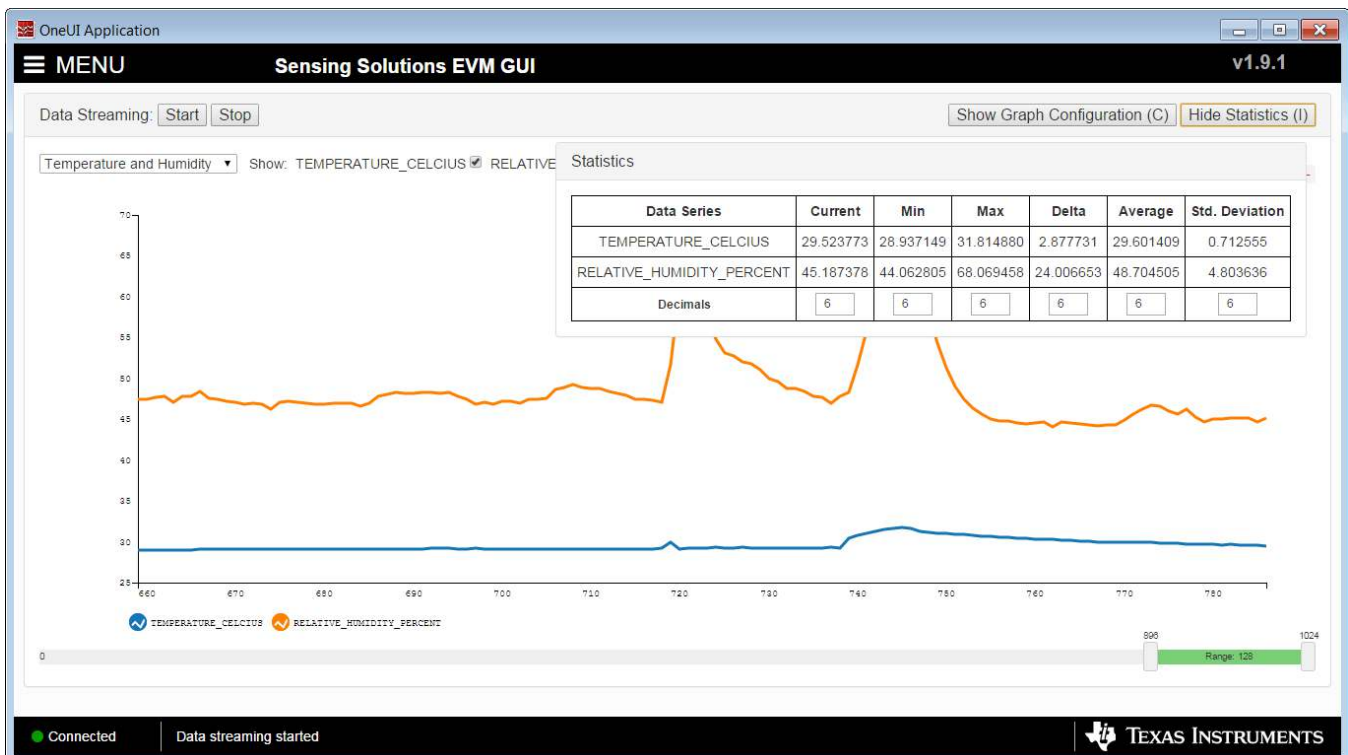

Figure 46. Data Statistics on Data Streaming Graph

3.6.6 Navigating the GUI's Data Buffer

After stopping the data stream, the number of data samples displayed can be selected by moving the dual slider under the graph.

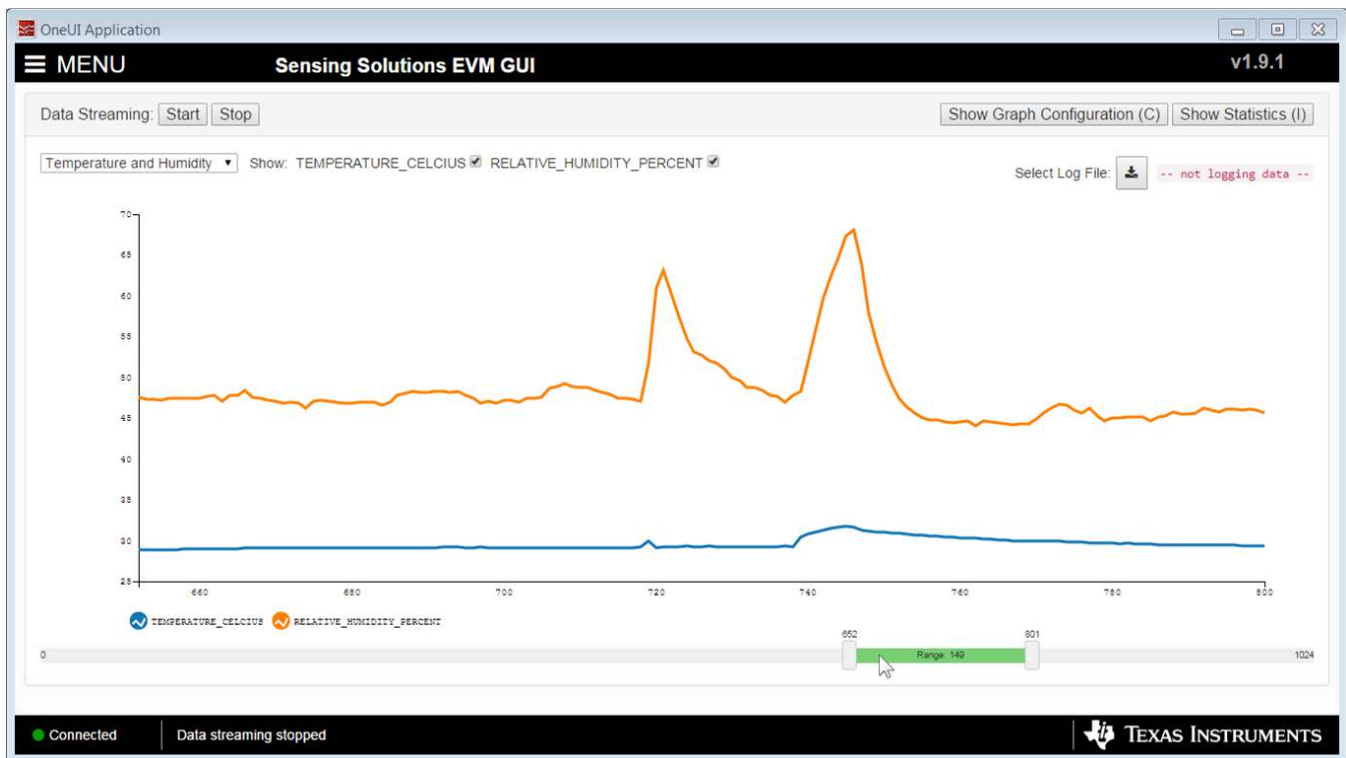

Figure 47. Moving the Data Graph Sample View

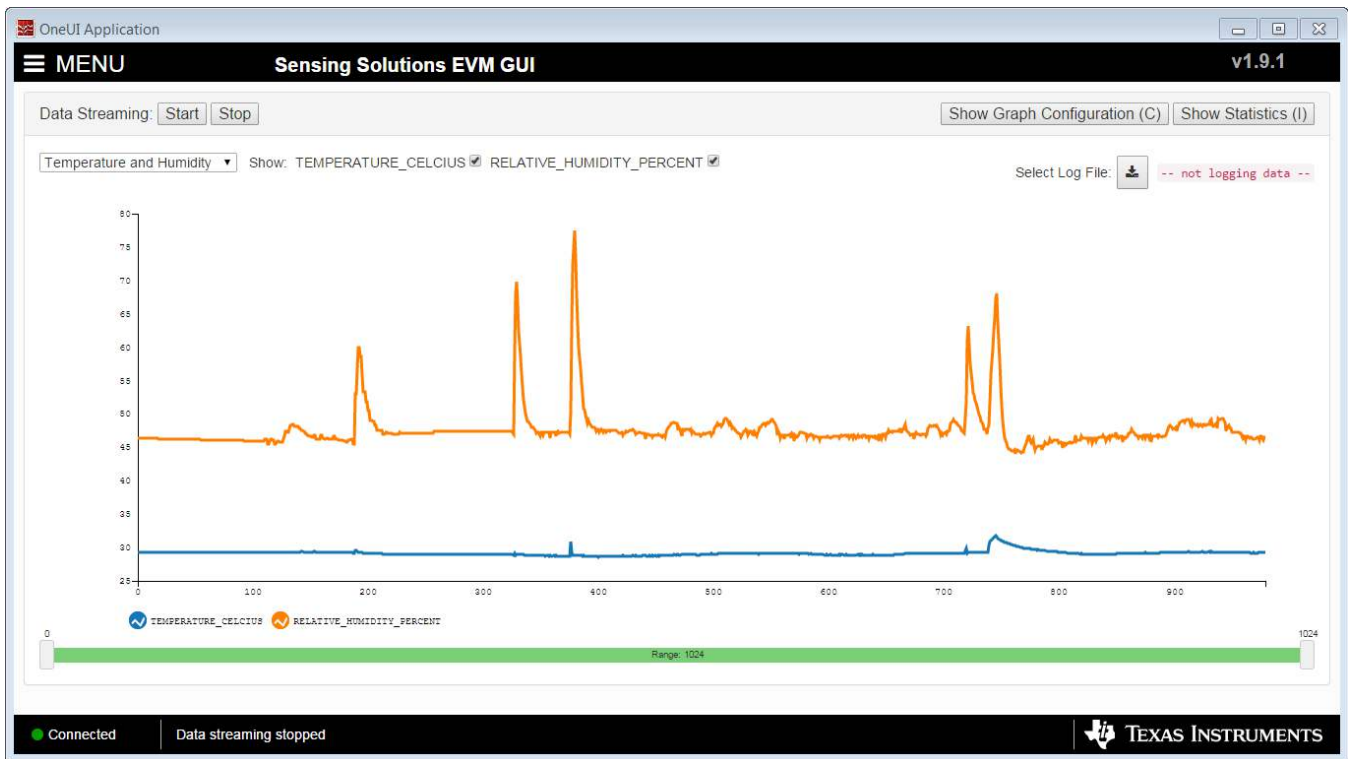

Figure 48. Viewing the Entire Buffer on Data Graph

3.7 Updating the EVM Firmware

To upload new firmware to the EVM, navigate to the "Firmware" page from the GUI menu and follow these steps.

1. Click the button to select a TI-TXT firmware file

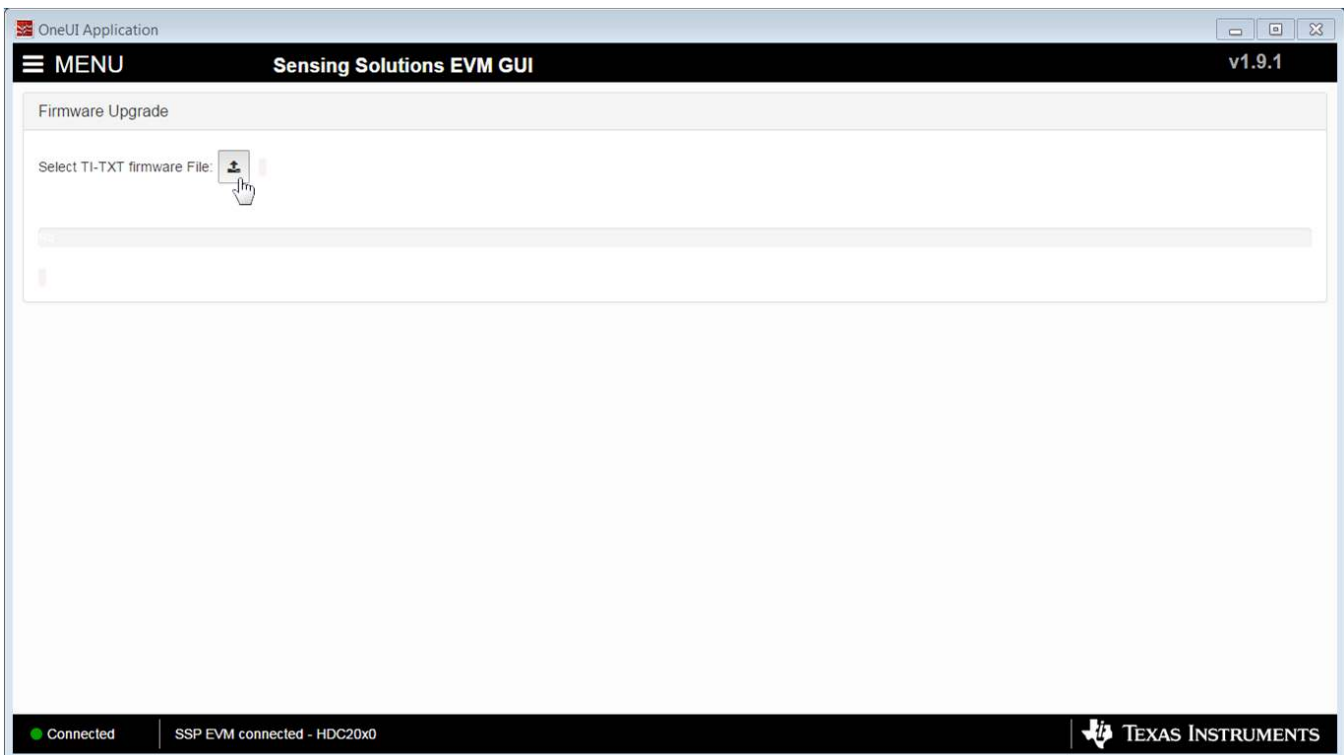

Figure 49. Select TI-TXT File Button on Firmware Upload Page

2. Select the firmware file and click “Open”

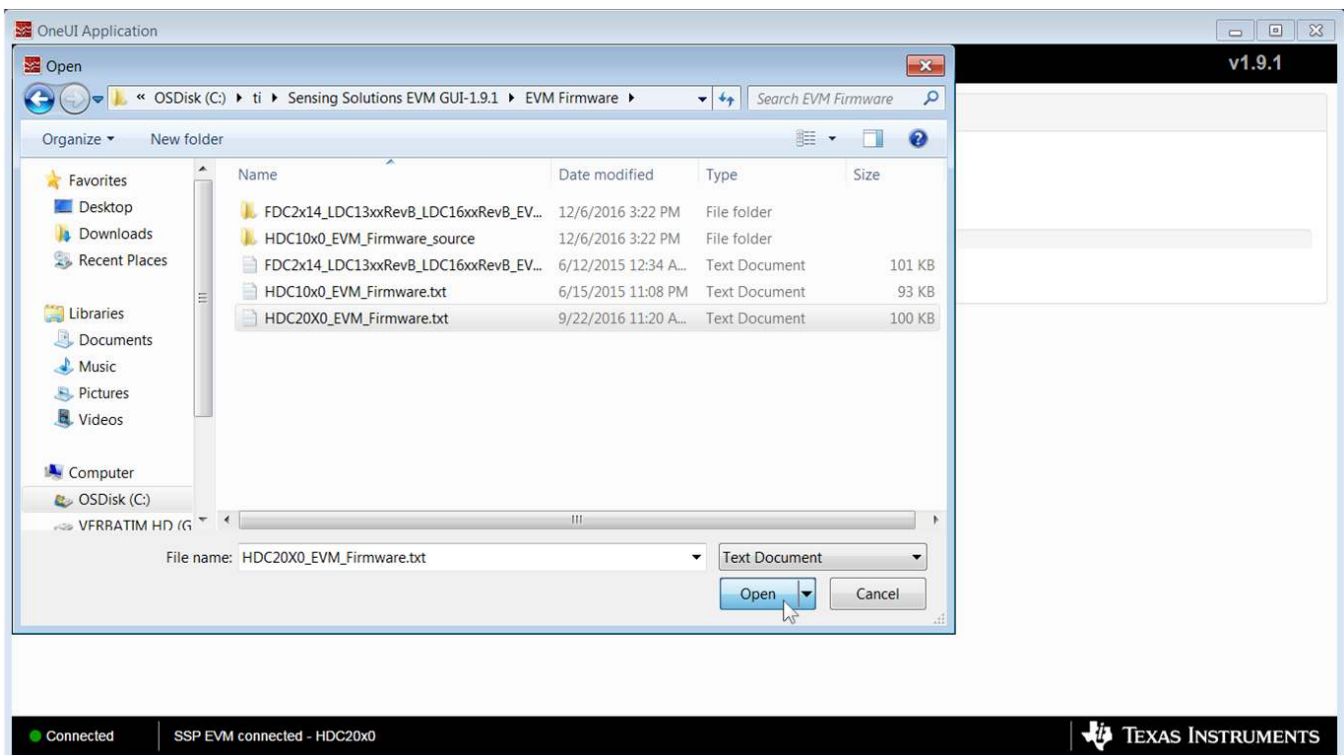

Figure 50. Selecting TI-TXT Firmware File for Upload to EVM

3. Click the “Upload Firmware” button.

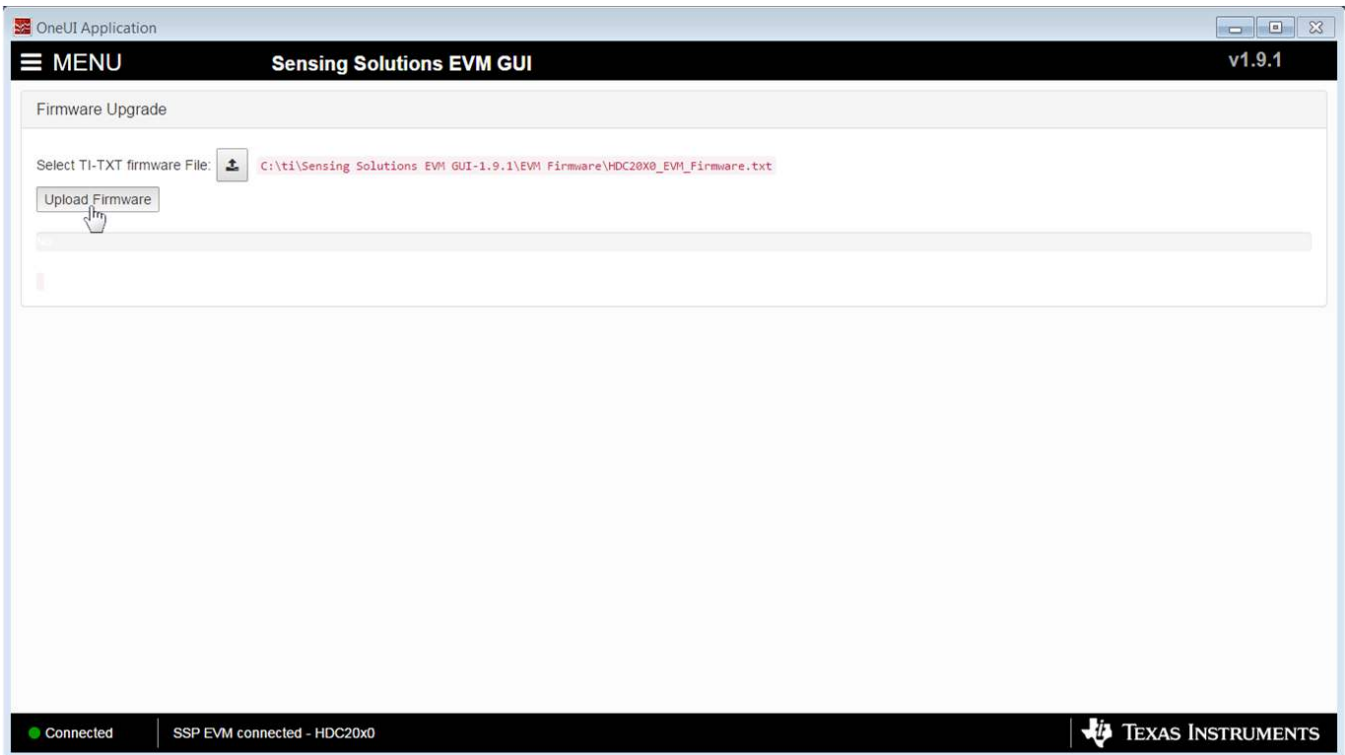

Figure 51. Upload Firmware Button on Firmware Upload Page

4. Wait for the firmware to upload. Do NOT disconnect the EVM from the PC at this time! Also note that the GUI will disconnect from the EVM. The upload process should not take more than one minute.

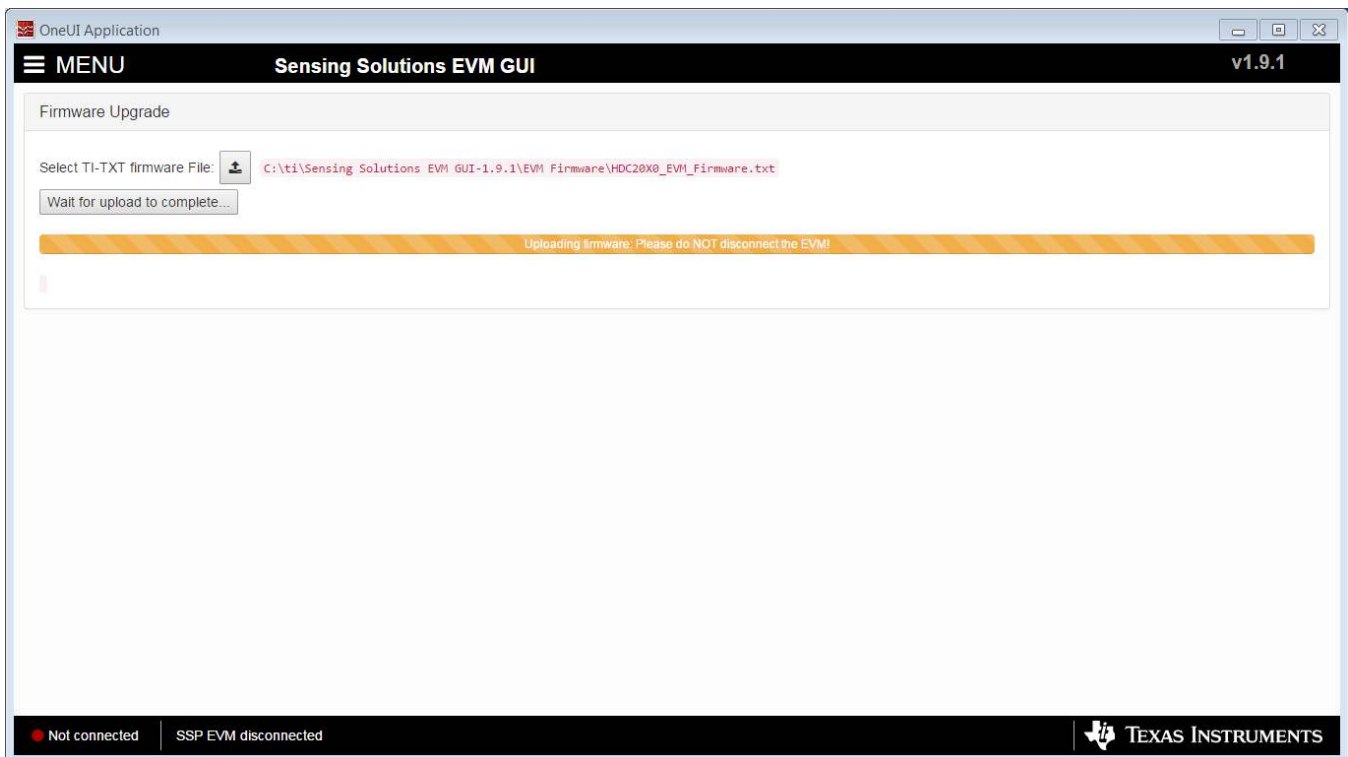

Figure 52. Firmware Upload in Progress

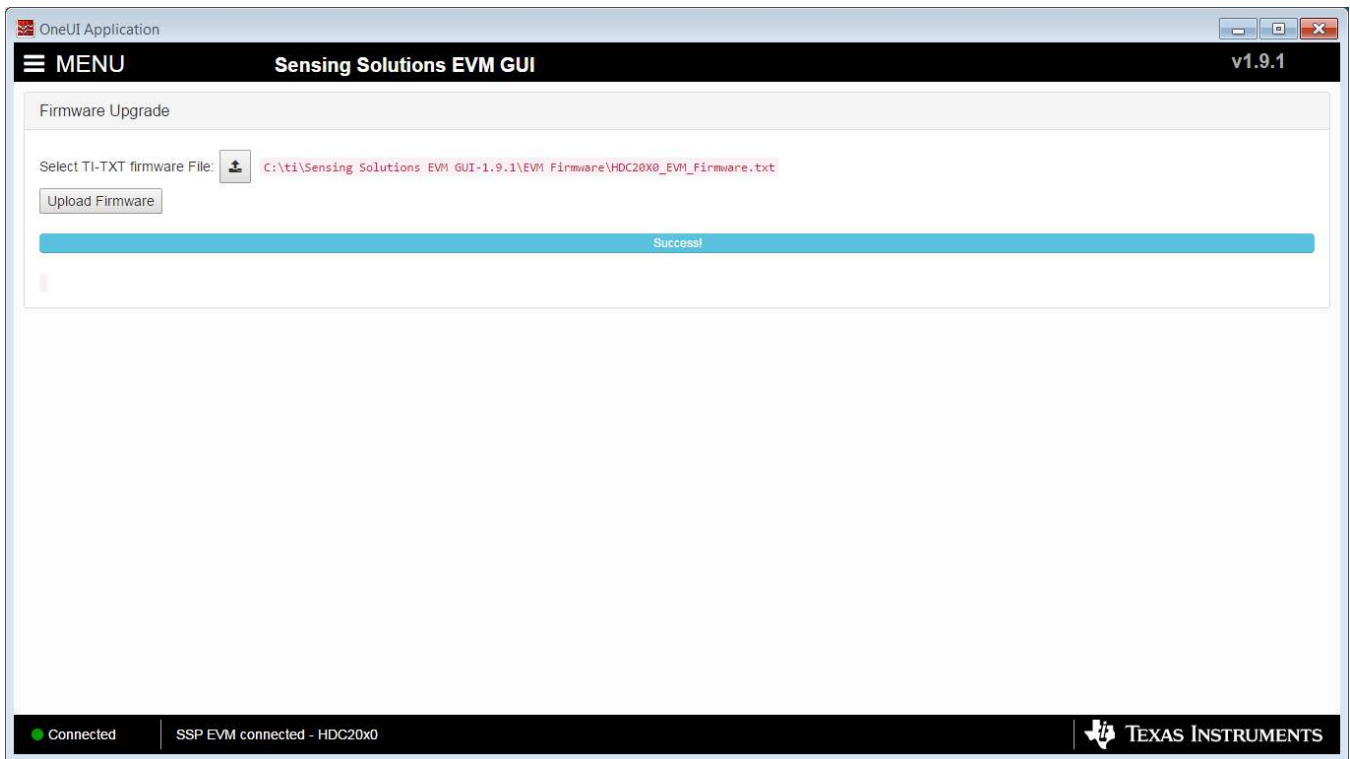

Figure 53. Firmware Upload Success

4 Board Layout

Figure 54 and Figure 55 show the board layout for the HDC2010EVM.

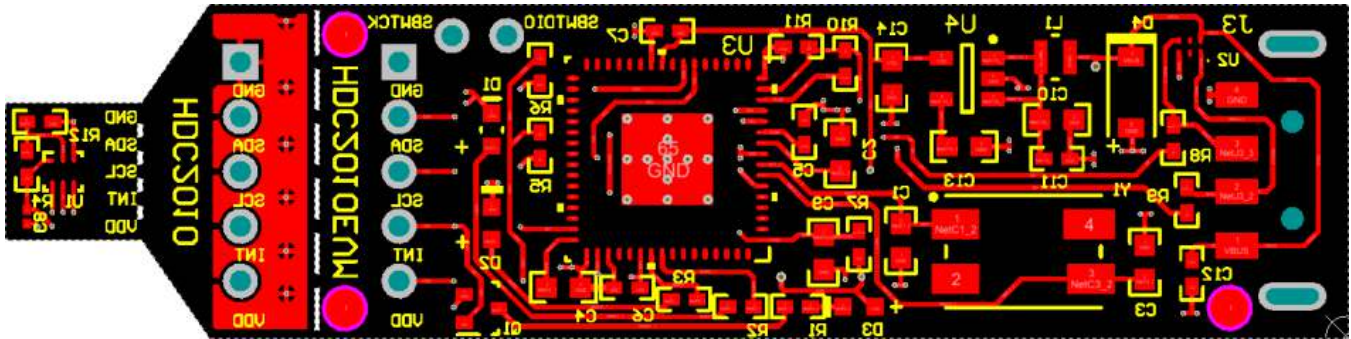

Figure 54. Top Layer Routing

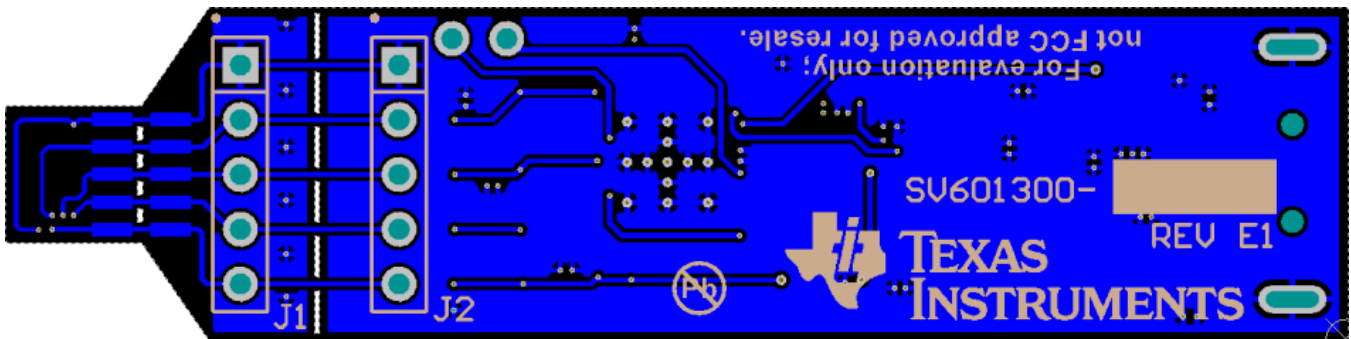

Figure 55. Bottom Layer Routing

5 Schematic

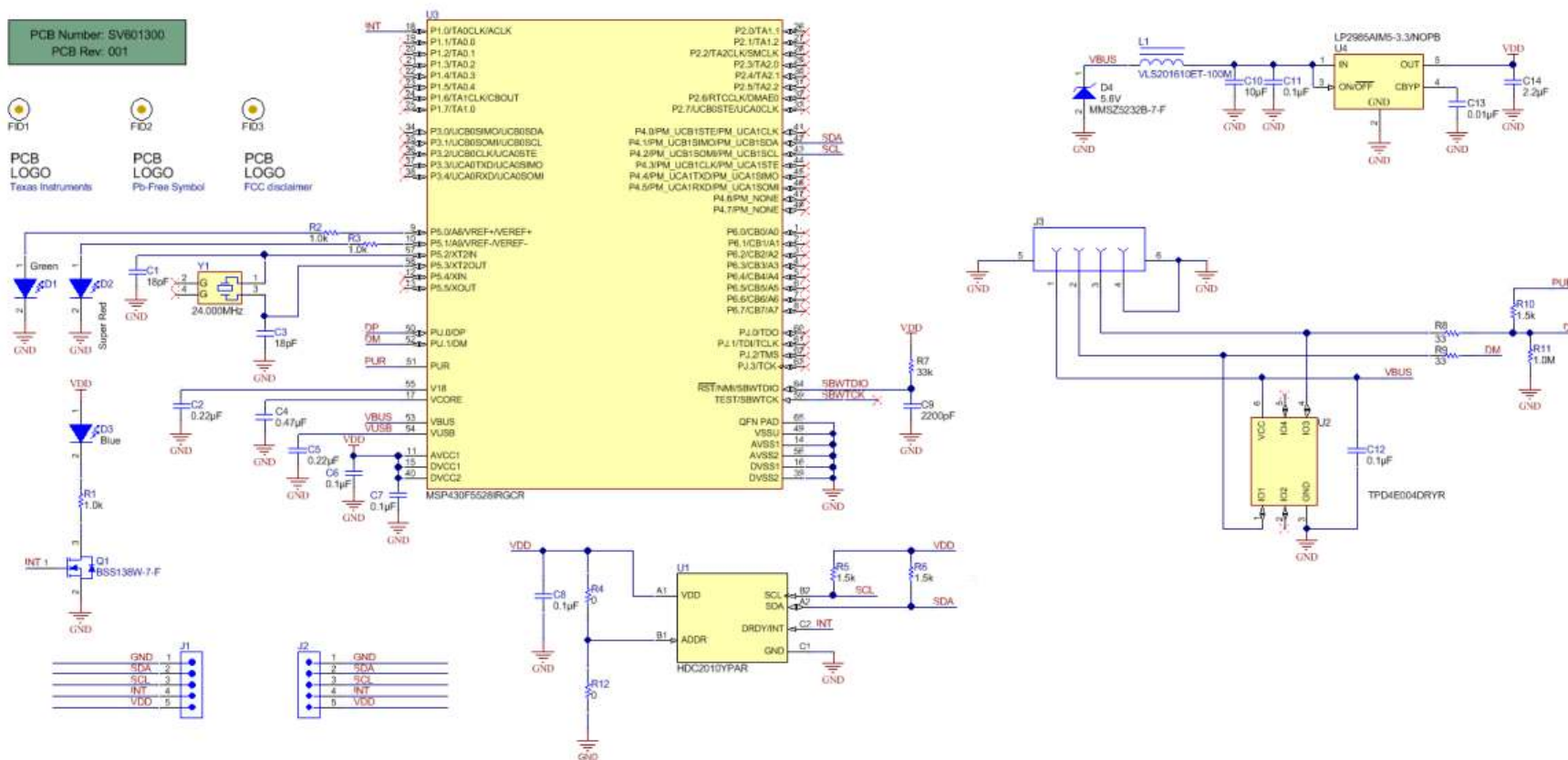

Figure 56. HDC2010EVM Schematic

6 HDC2010EVM Bill of Materials

COUNT	REF DES	DESCRIPTION	FOOTPRINT	PART NUMBER
2	C1, C3	CAP, CERM, 18pF, 100V, +/-5%, C0G/NP0, 0603	0603	GRM1885C2A180JA01D
1	C2	CAP, CERM, 0.22uF, 25V, +/-10%, X5R, 0603	0603	06033D224KAT2A
1	C4	CAP, CERM, 0.47uF, 10V, +/-10%, X7R, 0603	0603	C0603C474K8RACTU
1	C5	CAP, CERM, 0.22uF, 16V, +/-10%, X7R, 0402	0402	GRM155R71C224KA12D
4	C6, C7, C11, C12	CAP, CERM, 0.1 uF, 16 V, +/- 5%, X7R, 0402	0402	GRM155R71C104JA88D
1	C8	CAP, CERM, 0.1uF, 10V, +/-10%, X5R, 0201	0201	CL03A104KP3NNNC
1	C9	CAP, CERM, 2200pF, 50V, +/-10%, X7R, 0603	0603	C0603X222K5RACTU
1	C10	CAP, CERM, 10uF, 10V, +/-20%, X5R, 0603	0603	C1608X5R1A106M
1	C13	CAP, CERM, 0.01uF, 25V, +/-5%, C0G/NP0, 0603	0603	C1608C0G1E103J
1	C14	CAP, CERM, 2.2uF, 10V, +/-10%, X5R, 0603	0603	C0603C225K8PACTU
1	D1	LED, Green, SMD	1.7x0.65x0.8mm	LG L29K-G2J1-24-Z
1	D2	LED, Super Red, SMD	LED, 1.6x.6x.8mm	SML-LX0603SRW-TR
1	D3	LED, Blue, SMD	BLUE 0603 LED	LB Q39G-L2N2-35-1
1	D4	Diode, Zener, 5.6V, 500mW, SOD-123	SOD-123	MMSZ5232B-7-F
1	J3	Connector, USB Type A, 4POS R/A, SMD	VLS201610	48037-2200
1	L1	Inductor, Shielded, Ferrite, 10uH, 0.4A, 1.38 ohm, SMD	2.0x0.95x1.6mm	VLS201610ET-100M
1	Q1	MOSFET, N-CH, 50 V, 0.2 A, SOT-323	SOT-323	BSS138W-7-F
3	R1, R2, R3	RES, 1.0k ohm, 5%, 0.063W, 0402	0402	CRCW04021K00JNED
1	R5, R6, R10	RES, 1.5 k, 5%, 0.063 W, 0402	0402	CRCW04021K50JNED
1	R7	RES, 33k ohm, 5%, 0.063W, 0402	0402	CRCW040233K0JNED
2	R8, R9	RES, 33 ohm, 5%, 0.063W, 0402	0402	CRCW040233R0JNED
1	R11	RES, 1.0 M, 5%, 0.063 W, 0402	0402	CRCW04021M00JNED
1	R12	RES, 0, 5%, 0.063 W, 0402	0402	ERJ-2GE0R00X
1	U1	HDC2010 Low Power Humidity and Temperature Digital Sensor, YPA0006ABAB	YPA0006ABAB	HDC2010YPAR
1	U2	4-Channels ESD-Protection Array for High-Speed Data Interfaces	DRY0006A	TPD4E004DRY
1	U3	MSP430F5528 Mixed Signal micro-controller	RGC0064B	MSP430F5528IRGC
1	U4	Micropower 150 mA Low-Noise Ultra Low-Dropout Regulator, 5-pin SOT-23, Pb-Free	MF05A	LP2985AIM5-3.3/NOPB
1	Y1	CRYSTAL 24.000MHZ, 18pF, SMD	ABMM	ABMM-24.000MHZ-B2-T
0	J1, J2	Header, TH, 100mil, 5x1, Gold plated, 230 mil above insulator	5x1 Header	TSW-105-07-G-S
0	R4	RES, 0, 5%, 0.063 W, 0402	0402	ERJ-2GE0R00X

STANDARD TERMS FOR EVALUATION MODULES

1. *Delivery:* TI delivers TI evaluation boards, kits, or modules, including any accompanying demonstration software, components, and/or documentation which may be provided together or separately (collectively, an "EVM" or "EVMs") to the User ("User") in accordance with the terms set forth herein. User's acceptance of the EVM is expressly subject to the following terms.
 - 1.1 EVMs are intended solely for product or software developers for use in a research and development setting to facilitate feasibility evaluation, experimentation, or scientific analysis of TI semiconductor products. EVMs have no direct function and are not finished products. EVMs shall not be directly or indirectly assembled as a part or subassembly in any finished product. For clarification, any software or software tools provided with the EVM ("Software") shall not be subject to the terms and conditions set forth herein but rather shall be subject to the applicable terms that accompany such Software
 - 1.2 EVMs are not intended for consumer or household use. EVMs may not be sold, sublicensed, leased, rented, loaned, assigned, or otherwise distributed for commercial purposes by Users, in whole or in part, or used in any finished product or production system.
2. *Limited Warranty and Related Remedies/Disclaimers:*
 - 2.1 These terms do not apply to Software. The warranty, if any, for Software is covered in the applicable Software License Agreement.
 - 2.2 TI warrants that the TI EVM will conform to TI's published specifications for ninety (90) days after the date TI delivers such EVM to User. Notwithstanding the foregoing, TI shall not be liable for a nonconforming EVM if (a) the nonconformity was caused by neglect, misuse or mistreatment by an entity other than TI, including improper installation or testing, or for any EVMs that have been altered or modified in any way by an entity other than TI, (b) the nonconformity resulted from User's design, specifications or instructions for such EVMs or improper system design, or (c) User has not paid on time. Testing and other quality control techniques are used to the extent TI deems necessary. TI does not test all parameters of each EVM. User's claims against TI under this Section 2 are void if User fails to notify TI of any apparent defects in the EVMs within ten (10) business days after delivery, or of any hidden defects with ten (10) business days after the defect has been detected.
 - 2.3 TI's sole liability shall be at its option to repair or replace EVMs that fail to conform to the warranty set forth above, or credit User's account for such EVM. TI's liability under this warranty shall be limited to EVMs that are returned during the warranty period to the address designated by TI and that are determined by TI not to conform to such warranty. If TI elects to repair or replace such EVM, TI shall have a reasonable time to repair such EVM or provide replacements. Repaired EVMs shall be warranted for the remainder of the original warranty period. Replaced EVMs shall be warranted for a new full ninety (90) day warranty period.
3. *Regulatory Notices:*
 - 3.1 *United States*
 - 3.1.1 *Notice applicable to EVMs not FCC-Approved:*

FCC NOTICE: This kit is designed to allow product developers to evaluate electronic components, circuitry, or software associated with the kit to determine whether to incorporate such items in a finished product and software developers to write software applications for use with the end product. This kit is not a finished product and when assembled may not be resold or otherwise marketed unless all required FCC equipment authorizations are first obtained. Operation is subject to the condition that this product not cause harmful interference to licensed radio stations and that this product accept harmful interference. Unless the assembled kit is designed to operate under part 15, part 18 or part 95 of this chapter, the operator of the kit must operate under the authority of an FCC license holder or must secure an experimental authorization under part 5 of this chapter.
 - 3.1.2 *For EVMs annotated as FCC – FEDERAL COMMUNICATIONS COMMISSION Part 15 Compliant:*

CAUTION

This device complies with part 15 of the FCC Rules. Operation is subject to the following two conditions: (1) This device may not cause harmful interference, and (2) this device must accept any interference received, including interference that may cause undesired operation.

Changes or modifications not expressly approved by the party responsible for compliance could void the user's authority to operate the equipment.

FCC Interference Statement for Class A EVM devices

NOTE: This equipment has been tested and found to comply with the limits for a Class A digital device, pursuant to part 15 of the FCC Rules. These limits are designed to provide reasonable protection against harmful interference when the equipment is operated in a commercial environment. This equipment generates, uses, and can radiate radio frequency energy and, if not installed and used in accordance with the instruction manual, may cause harmful interference to radio communications. Operation of this equipment in a residential area is likely to cause harmful interference in which case the user will be required to correct the interference at his own expense.

FCC Interference Statement for Class B EVM devices

NOTE: This equipment has been tested and found to comply with the limits for a Class B digital device, pursuant to part 15 of the FCC Rules. These limits are designed to provide reasonable protection against harmful interference in a residential installation. This equipment generates, uses and can radiate radio frequency energy and, if not installed and used in accordance with the instructions, may cause harmful interference to radio communications. However, there is no guarantee that interference will not occur in a particular installation. If this equipment does cause harmful interference to radio or television reception, which can be determined by turning the equipment off and on, the user is encouraged to try to correct the interference by one or more of the following measures:

- Reorient or relocate the receiving antenna.
- Increase the separation between the equipment and receiver.
- Connect the equipment into an outlet on a circuit different from that to which the receiver is connected.
- Consult the dealer or an experienced radio/TV technician for help.

3.2 Canada

3.2.1 For EVMs issued with an Industry Canada Certificate of Conformance to RSS-210 or RSS-247

Concerning EVMs Including Radio Transmitters:

This device complies with Industry Canada license-exempt RSSs. Operation is subject to the following two conditions:

(1) this device may not cause interference, and (2) this device must accept any interference, including interference that may cause undesired operation of the device.

Concernant les EVMs avec appareils radio:

Le présent appareil est conforme aux CNR d'Industrie Canada applicables aux appareils radio exempts de licence. L'exploitation est autorisée aux deux conditions suivantes: (1) l'appareil ne doit pas produire de brouillage, et (2) l'utilisateur de l'appareil doit accepter tout brouillage radioélectrique subi, même si le brouillage est susceptible d'en compromettre le fonctionnement.

Concerning EVMs Including Detachable Antennas:

Under Industry Canada regulations, this radio transmitter may only operate using an antenna of a type and maximum (or lesser) gain approved for the transmitter by Industry Canada. To reduce potential radio interference to other users, the antenna type and its gain should be so chosen that the equivalent isotropically radiated power (e.i.r.p.) is not more than that necessary for successful communication. This radio transmitter has been approved by Industry Canada to operate with the antenna types listed in the user guide with the maximum permissible gain and required antenna impedance for each antenna type indicated. Antenna types not included in this list, having a gain greater than the maximum gain indicated for that type, are strictly prohibited for use with this device.

Concernant les EVMs avec antennes détachables

Conformément à la réglementation d'Industrie Canada, le présent émetteur radio peut fonctionner avec une antenne d'un type et d'un gain maximal (ou inférieur) approuvé pour l'émetteur par Industrie Canada. Dans le but de réduire les risques de brouillage radioélectrique à l'intention des autres utilisateurs, il faut choisir le type d'antenne et son gain de sorte que la puissance isotrope rayonnée équivalente (p.i.r.e.) ne dépasse pas l'intensité nécessaire à l'établissement d'une communication satisfaisante. Le présent émetteur radio a été approuvé par Industrie Canada pour fonctionner avec les types d'antenne énumérés dans le manuel d'usage et ayant un gain admissible maximal et l'impédance requise pour chaque type d'antenne. Les types d'antenne non inclus dans cette liste, ou dont le gain est supérieur au gain maximal indiqué, sont strictement interdits pour l'exploitation de l'émetteur.

3.3 Japan

3.3.1 *Notice for EVMs delivered in Japan:* Please see http://www.tij.co.jp/lstds/ti_ja/general/eStore/notice_01.page 日本国内に輸入される評価用キット、ボードについては、次のところをご覧ください。
http://www.tij.co.jp/lstds/ti_ja/general/eStore/notice_01.page

3.3.2 *Notice for Users of EVMs Considered "Radio Frequency Products" in Japan:* EVMs entering Japan may not be certified by TI as conforming to Technical Regulations of Radio Law of Japan.

If User uses EVMs in Japan, not certified to Technical Regulations of Radio Law of Japan, User is required to follow the instructions set forth by Radio Law of Japan, which includes, but is not limited to, the instructions below with respect to EVMs (which for the avoidance of doubt are stated strictly for convenience and should be verified by User):

1. Use EVMs in a shielded room or any other test facility as defined in the notification #173 issued by Ministry of Internal Affairs and Communications on March 28, 2006, based on Sub-section 1.1 of Article 6 of the Ministry's Rule for Enforcement of Radio Law of Japan,
2. Use EVMs only after User obtains the license of Test Radio Station as provided in Radio Law of Japan with respect to EVMs, or
3. Use of EVMs only after User obtains the Technical Regulations Conformity Certification as provided in Radio Law of Japan with respect to EVMs. Also, do not transfer EVMs, unless User gives the same notice above to the transferee. Please note that if User does not follow the instructions above, User will be subject to penalties of Radio Law of Japan.

【無線電波を送信する製品の開発キットをお使いになる際の注意事項】 開発キットの中には技術基準適合証明を受けていないものがあります。技術適合証明を受けていないものご使用に際しては、電波法遵守のため、以下のいずれかの措置を取っていただく必要がありますのでご注意ください。

1. 電波法施行規則第6条第1項第1号に基づく平成18年3月28日総務省告示第173号で定められた電波暗室等の試験設備でご使用いただく。
2. 実験局の免許を取得後ご使用いただく。
3. 技術基準適合証明を取得後ご使用いただく。

なお、本製品は、上記の「ご使用にあたっての注意」を譲渡先、移転先に通知しない限り、譲渡、移転できないものとします。

上記を遵守頂けない場合は、電波法の罰則が適用される可能性があることをご留意ください。日本テキサス・インスツルメンツ株式会社
東京都新宿区西新宿 6 丁目 2 4 番 1 号
西新宿三井ビル

3.3.3 *Notice for EVMs for Power Line Communication:* Please see http://www.tij.co.jp/llds/ti_ja/general/eStore/notice_02.page
電力線搬送波通信についての開発キットをお使いになる際の注意事項については、次のところをご覧ください。 http://www.tij.co.jp/llds/ti_ja/general/eStore/notice_02.page

3.4 *European Union*

3.4.1 *For EVMs subject to EU Directive 2014/30/EU (Electromagnetic Compatibility Directive):*

This is a class A product intended for use in environments other than domestic environments that are connected to a low-voltage power-supply network that supplies buildings used for domestic purposes. In a domestic environment this product may cause radio interference in which case the user may be required to take adequate measures.

4 *EVM Use Restrictions and Warnings:*

4.1 EVMS ARE NOT FOR USE IN FUNCTIONAL SAFETY AND/OR SAFETY CRITICAL EVALUATIONS, INCLUDING BUT NOT LIMITED TO EVALUATIONS OF LIFE SUPPORT APPLICATIONS.

4.2 User must read and apply the user guide and other available documentation provided by TI regarding the EVM prior to handling or using the EVM, including without limitation any warning or restriction notices. The notices contain important safety information related to, for example, temperatures and voltages.

4.3 *Safety-Related Warnings and Restrictions:*

4.3.1 User shall operate the EVM within TI's recommended specifications and environmental considerations stated in the user guide, other available documentation provided by TI, and any other applicable requirements and employ reasonable and customary safeguards. Exceeding the specified performance ratings and specifications (including but not limited to input and output voltage, current, power, and environmental ranges) for the EVM may cause personal injury or death, or property damage. If there are questions concerning performance ratings and specifications, User should contact a TI field representative prior to connecting interface electronics including input power and intended loads. Any loads applied outside of the specified output range may also result in unintended and/or inaccurate operation and/or possible permanent damage to the EVM and/or interface electronics. Please consult the EVM user guide prior to connecting any load to the EVM output. If there is uncertainty as to the load specification, please contact a TI field representative. During normal operation, even with the inputs and outputs kept within the specified allowable ranges, some circuit components may have elevated case temperatures. These components include but are not limited to linear regulators, switching transistors, pass transistors, current sense resistors, and heat sinks, which can be identified using the information in the associated documentation. When working with the EVM, please be aware that the EVM may become very warm.

4.3.2 EVMs are intended solely for use by technically qualified, professional electronics experts who are familiar with the dangers and application risks associated with handling electrical mechanical components, systems, and subsystems. User assumes all responsibility and liability for proper and safe handling and use of the EVM by User or its employees, affiliates, contractors or designees. User assumes all responsibility and liability to ensure that any interfaces (electronic and/or mechanical) between the EVM and any human body are designed with suitable isolation and means to safely limit accessible leakage currents to minimize the risk of electrical shock hazard. User assumes all responsibility and liability for any improper or unsafe handling or use of the EVM by User or its employees, affiliates, contractors or designees.

4.4 User assumes all responsibility and liability to determine whether the EVM is subject to any applicable international, federal, state, or local laws and regulations related to User's handling and use of the EVM and, if applicable, User assumes all responsibility and liability for compliance in all respects with such laws and regulations. User assumes all responsibility and liability for proper disposal and recycling of the EVM consistent with all applicable international, federal, state, and local requirements.

5. *Accuracy of Information:* To the extent TI provides information on the availability and function of EVMs, TI attempts to be as accurate as possible. However, TI does not warrant the accuracy of EVM descriptions, EVM availability or other information on its websites as accurate, complete, reliable, current, or error-free.

6. *Disclaimers:*
- 6.1 EXCEPT AS SET FORTH ABOVE, EVMS AND ANY MATERIALS PROVIDED WITH THE EVM (INCLUDING, BUT NOT LIMITED TO, REFERENCE DESIGNS AND THE DESIGN OF THE EVM ITSELF) ARE PROVIDED "AS IS" AND "WITH ALL FAULTS." TI DISCLAIMS ALL OTHER WARRANTIES, EXPRESS OR IMPLIED, REGARDING SUCH ITEMS, INCLUDING BUT NOT LIMITED TO ANY EPIDEMIC FAILURE WARRANTY OR IMPLIED WARRANTIES OF MERCHANTABILITY OR FITNESS FOR A PARTICULAR PURPOSE OR NON-INFRINGEMENT OF ANY THIRD PARTY PATENTS, COPYRIGHTS, TRADE SECRETS OR OTHER INTELLECTUAL PROPERTY RIGHTS.
- 6.2 EXCEPT FOR THE LIMITED RIGHT TO USE THE EVM SET FORTH HEREIN, NOTHING IN THESE TERMS SHALL BE CONSTRUED AS GRANTING OR CONFERRING ANY RIGHTS BY LICENSE, PATENT, OR ANY OTHER INDUSTRIAL OR INTELLECTUAL PROPERTY RIGHT OF TI, ITS SUPPLIERS/LICENSORS OR ANY OTHER THIRD PARTY, TO USE THE EVM IN ANY FINISHED END-USER OR READY-TO-USE FINAL PRODUCT, OR FOR ANY INVENTION, DISCOVERY OR IMPROVEMENT, REGARDLESS OF WHEN MADE, CONCEIVED OR ACQUIRED.
7. *USER'S INDEMNITY OBLIGATIONS AND REPRESENTATIONS.* USER WILL DEFEND, INDEMNIFY AND HOLD TI, ITS LICENSORS AND THEIR REPRESENTATIVES HARMLESS FROM AND AGAINST ANY AND ALL CLAIMS, DAMAGES, LOSSES, EXPENSES, COSTS AND LIABILITIES (COLLECTIVELY, "CLAIMS") ARISING OUT OF OR IN CONNECTION WITH ANY HANDLING OR USE OF THE EVM THAT IS NOT IN ACCORDANCE WITH THESE TERMS. THIS OBLIGATION SHALL APPLY WHETHER CLAIMS ARISE UNDER STATUTE, REGULATION, OR THE LAW OF TORT, CONTRACT OR ANY OTHER LEGAL THEORY, AND EVEN IF THE EVM FAILS TO PERFORM AS DESCRIBED OR EXPECTED.
8. *Limitations on Damages and Liability:*
- 8.1 *General Limitations.* IN NO EVENT SHALL TI BE LIABLE FOR ANY SPECIAL, COLLATERAL, INDIRECT, PUNITIVE, INCIDENTAL, CONSEQUENTIAL, OR EXEMPLARY DAMAGES IN CONNECTION WITH OR ARISING OUT OF THESE TERMS OR THE USE OF THE EVMS , REGARDLESS OF WHETHER TI HAS BEEN ADVISED OF THE POSSIBILITY OF SUCH DAMAGES. EXCLUDED DAMAGES INCLUDE, BUT ARE NOT LIMITED TO, COST OF REMOVAL OR REINSTALLATION, ANCILLARY COSTS TO THE PROCUREMENT OF SUBSTITUTE GOODS OR SERVICES, RETESTING, OUTSIDE COMPUTER TIME, LABOR COSTS, LOSS OF GOODWILL, LOSS OF PROFITS, LOSS OF SAVINGS, LOSS OF USE, LOSS OF DATA, OR BUSINESS INTERRUPTION. NO CLAIM, SUIT OR ACTION SHALL BE BROUGHT AGAINST TI MORE THAN TWELVE (12) MONTHS AFTER THE EVENT THAT GAVE RISE TO THE CAUSE OF ACTION HAS OCCURRED.
- 8.2 *Specific Limitations.* IN NO EVENT SHALL TI'S AGGREGATE LIABILITY FROM ANY USE OF AN EVM PROVIDED HEREUNDER, INCLUDING FROM ANY WARRANTY, INDEMNITY OR OTHER OBLIGATION ARISING OUT OF OR IN CONNECTION WITH THESE TERMS, , EXCEED THE TOTAL AMOUNT PAID TO TI BY USER FOR THE PARTICULAR EVM(S) AT ISSUE DURING THE PRIOR TWELVE (12) MONTHS WITH RESPECT TO WHICH LOSSES OR DAMAGES ARE CLAIMED. THE EXISTENCE OF MORE THAN ONE CLAIM SHALL NOT ENLARGE OR EXTEND THIS LIMIT.
9. *Return Policy.* Except as otherwise provided, TI does not offer any refunds, returns, or exchanges. Furthermore, no return of EVM(s) will be accepted if the package has been opened and no return of the EVM(s) will be accepted if they are damaged or otherwise not in a resalable condition. If User feels it has been incorrectly charged for the EVM(s) it ordered or that delivery violates the applicable order, User should contact TI. All refunds will be made in full within thirty (30) working days from the return of the components(s), excluding any postage or packaging costs.
10. *Governing Law:* These terms and conditions shall be governed by and interpreted in accordance with the laws of the State of Texas, without reference to conflict-of-laws principles. User agrees that non-exclusive jurisdiction for any dispute arising out of or relating to these terms and conditions lies within courts located in the State of Texas and consents to venue in Dallas County, Texas. Notwithstanding the foregoing, any judgment may be enforced in any United States or foreign court, and TI may seek injunctive relief in any United States or foreign court.

IMPORTANT NOTICE FOR TI DESIGN INFORMATION AND RESOURCES

Texas Instruments Incorporated ("TI") technical, application or other design advice, services or information, including, but not limited to, reference designs and materials relating to evaluation modules, (collectively, "TI Resources") are intended to assist designers who are developing applications that incorporate TI products; by downloading, accessing or using any particular TI Resource in any way, you (individually or, if you are acting on behalf of a company, your company) agree to use it solely for this purpose and subject to the terms of this Notice.

TI's provision of TI Resources does not expand or otherwise alter TI's applicable published warranties or warranty disclaimers for TI products, and no additional obligations or liabilities arise from TI providing such TI Resources. TI reserves the right to make corrections, enhancements, improvements and other changes to its TI Resources.

You understand and agree that you remain responsible for using your independent analysis, evaluation and judgment in designing your applications and that you have full and exclusive responsibility to assure the safety of your applications and compliance of your applications (and of all TI products used in or for your applications) with all applicable regulations, laws and other applicable requirements. You represent that, with respect to your applications, you have all the necessary expertise to create and implement safeguards that (1) anticipate dangerous consequences of failures, (2) monitor failures and their consequences, and (3) lessen the likelihood of failures that might cause harm and take appropriate actions. You agree that prior to using or distributing any applications that include TI products, you will thoroughly test such applications and the functionality of such TI products as used in such applications. TI has not conducted any testing other than that specifically described in the published documentation for a particular TI Resource.

You are authorized to use, copy and modify any individual TI Resource only in connection with the development of applications that include the TI product(s) identified in such TI Resource. NO OTHER LICENSE, EXPRESS OR IMPLIED, BY ESTOPPEL OR OTHERWISE TO ANY OTHER TI INTELLECTUAL PROPERTY RIGHT, AND NO LICENSE TO ANY TECHNOLOGY OR INTELLECTUAL PROPERTY RIGHT OF TI OR ANY THIRD PARTY IS GRANTED HEREIN, including but not limited to any patent right, copyright, mask work right, or other intellectual property right relating to any combination, machine, or process in which TI products or services are used. Information regarding or referencing third-party products or services does not constitute a license to use such products or services, or a warranty or endorsement thereof. Use of TI Resources may require a license from a third party under the patents or other intellectual property of the third party, or a license from TI under the patents or other intellectual property of TI.

TI RESOURCES ARE PROVIDED "AS IS" AND WITH ALL FAULTS. TI DISCLAIMS ALL OTHER WARRANTIES OR REPRESENTATIONS, EXPRESS OR IMPLIED, REGARDING TI RESOURCES OR USE THEREOF, INCLUDING BUT NOT LIMITED TO ACCURACY OR COMPLETENESS, TITLE, ANY EPIDEMIC FAILURE WARRANTY AND ANY IMPLIED WARRANTIES OF MERCHANTABILITY, FITNESS FOR A PARTICULAR PURPOSE, AND NON-INFRINGEMENT OF ANY THIRD PARTY INTELLECTUAL PROPERTY RIGHTS.

TI SHALL NOT BE LIABLE FOR AND SHALL NOT DEFEND OR INDEMNIFY YOU AGAINST ANY CLAIM, INCLUDING BUT NOT LIMITED TO ANY INFRINGEMENT CLAIM THAT RELATES TO OR IS BASED ON ANY COMBINATION OF PRODUCTS EVEN IF DESCRIBED IN TI RESOURCES OR OTHERWISE. IN NO EVENT SHALL TI BE LIABLE FOR ANY ACTUAL, DIRECT, SPECIAL, COLLATERAL, INDIRECT, PUNITIVE, INCIDENTAL, CONSEQUENTIAL OR EXEMPLARY DAMAGES IN CONNECTION WITH OR ARISING OUT OF TI RESOURCES OR USE THEREOF, AND REGARDLESS OF WHETHER TI HAS BEEN ADVISED OF THE POSSIBILITY OF SUCH DAMAGES.

You agree to fully indemnify TI and its representatives against any damages, costs, losses, and/or liabilities arising out of your non-compliance with the terms and provisions of this Notice.

This Notice applies to TI Resources. Additional terms apply to the use and purchase of certain types of materials, TI products and services. These include; without limitation, TI's standard terms for semiconductor products (<http://www.ti.com/sc/docs/stdterms.htm>), [evaluation modules](#), and [samples](http://www.ti.com/sc/docs/sampterm.htm) (<http://www.ti.com/sc/docs/sampterm.htm>).

Mailing Address: Texas Instruments, Post Office Box 655303, Dallas, Texas 75265
Copyright © 2017, Texas Instruments Incorporated