



SCP1000 DEMO KIT
User Manual

TABLE OF CONTENTS

1	Introduction	3
2	Quick start for using the SCP1000 DEMO KIT	3
3	Hardware.....	4
4	GUI software	5
4.1	GUI software displays	7
4.1.1	USB serial port selection	7
4.1.2	Start up and Reset demo	7
4.1.3	Meas results	8
4.1.4	Register config	8
4.1.5	Pres offset adjustment.....	9
4.1.6	Setup.....	10
4.2	Uninstalling the GUI and USB driver.....	10
5	Using the SCP1000 demo without the GUI software	11
5.1	Establishing the connection.....	11
5.2	Communication commands.....	12
6	Using two SCP1000 demo kits simultaneously	14
7	USB interface board circuit diagram	15
8	USB interface board PCB layout.....	17
9	Troubleshooting	18
10	Document Revision History	19
11	Contact Information	19

1 Introduction

The SCP1000 pressure demonstrator is designed to give a quick access and understanding on the performance and capabilities of the SCP1000 pressure component. This document describes how to install the required software and how to use the SCP1000 DEMO KIT and Graphical User Interface (GUI) software version 2.5.

SCP1000 DEMO KIT package includes:

- SCP1000-D01 sensor soldered on chip carrier PCB (see Figure 1 on next page)
- USB interface card inside the demo box (see Figure 1 on next page)
- USB cable
- CD-ROM with documentation, drivers and GUI software running on PC

The SCP1000 DEMO KIT supports SCP1000-D01 and SCP1000-D11 sensors.

The graphical user interface is designed and tested to run in most commercial computers. System requirements:

- Operating system: Windows XP or Windows 2000 with SP1 or higher
- Communication interface: USB 2.0 or 1.0

The SCP1000 demo is powered from the USB port. For minimizing the noise introduced by the host PC in pressure measurements, a laptop operating on battery is recommended (mains supply disconnected).

2 Quick start for using the SCP1000 DEMO KIT

Please follow the steps below:

1. Insert CD-ROM
2. Setup the hardware
 - Connect the USB cable to the demo and to PC's USB port
3. Install the USB driver, after the PC has found the device
 - When the PC detects the new USB device, do not let Windows to detect the driver, address the USB driver from folder:
CD-ROM\SCP1000 demo - Virtual Com Port Drivers\
- NOTICE, if you have already installed the SCA3000 demo to your computer, you do not need to install the USB driver for the SCP1000 demo
4. Install the GUI software
 - Install the GUI software by running the "setup.exe" from folder:
CD-ROM\SCP1000 demo - ver 2.5 - Installer
 - Do not change the installation destination
5. Start the GUI software
 - From Start → Programs → SCP1000-USB-DEMO-VER.2.5
→ SCP1000-USB-DEMO-VER.2.5

When using the SCP1000 DEMO KIT with GUI software:

- The DEMO KIT should be connected to PC before the GUI software is started
- Exit the GUI software before unplugging the DEMO KIT from PC (button in upper right corner of the GUI)
- After GUI software is stopped, the DEMO KIT can be unplugged from the PC (the SCP1000 DEMO KIT uses virtual serial COM port driver, so it can not be found as a USB device).

3 Hardware

The SCP1000 DEMO KIT USB interface board and SCP1000 PCB are shown in Figure 1. The USB interface card converts the USB interface to SPI or TWI interface. The SCP1000 pressure sensor is soldered on chip carrier PCB which is connected to interface board with board to board connectors.

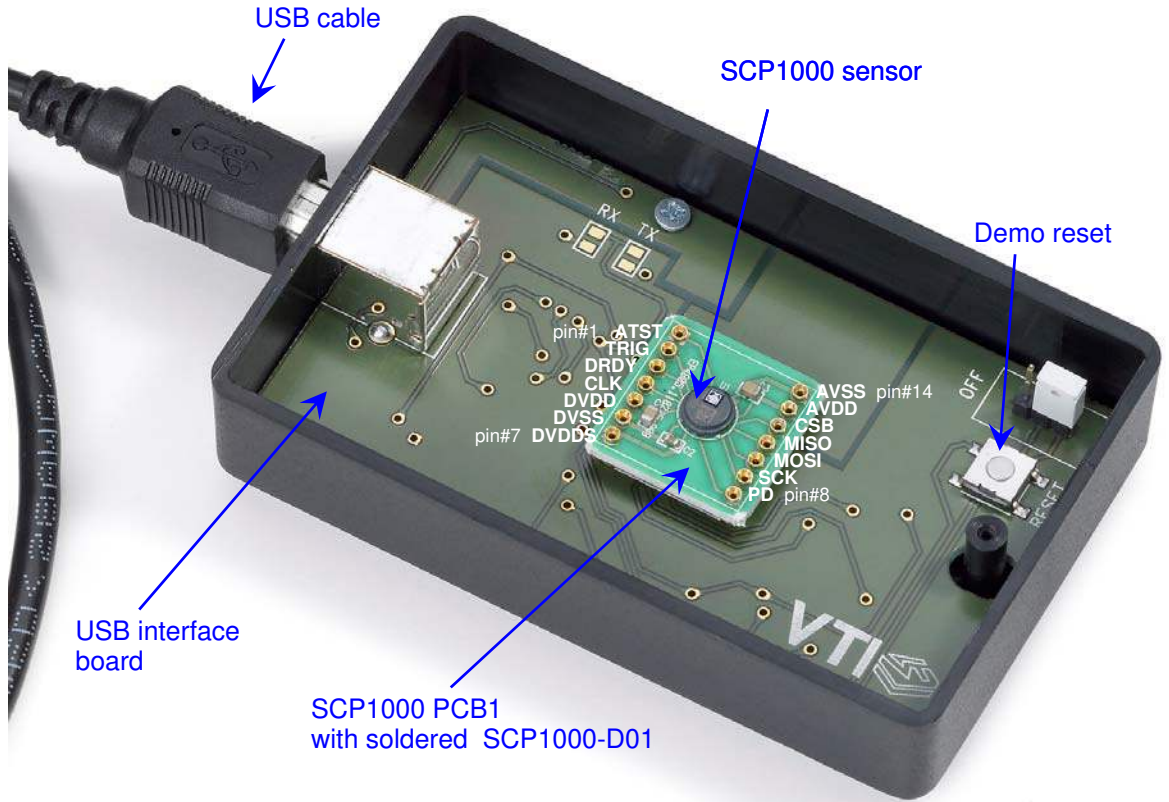

Figure 1. SCP1000 DEMO KIT USB interface board and SCP1000 PCB.

The SCP1000 DEMO KIT block diagram is presented in Figure 2 below.

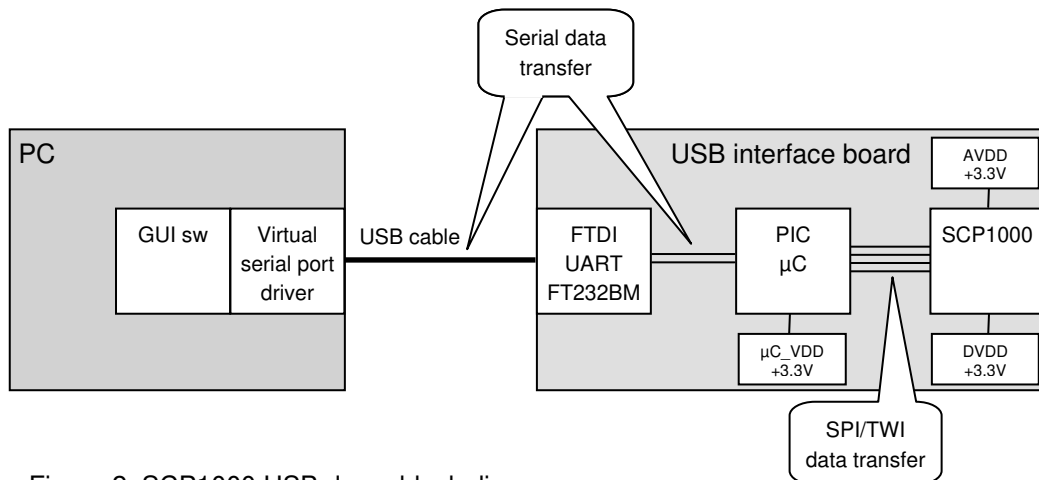

Figure 2. SCP1000 USB demo block diagram.

4 GUI software

SCP1000 DEMO KIT is controlled via USB serial port by GUI software. The software must be installed into location that is suggested during installation procedure.

Screen capture of the GUI is presented in Figure 3.

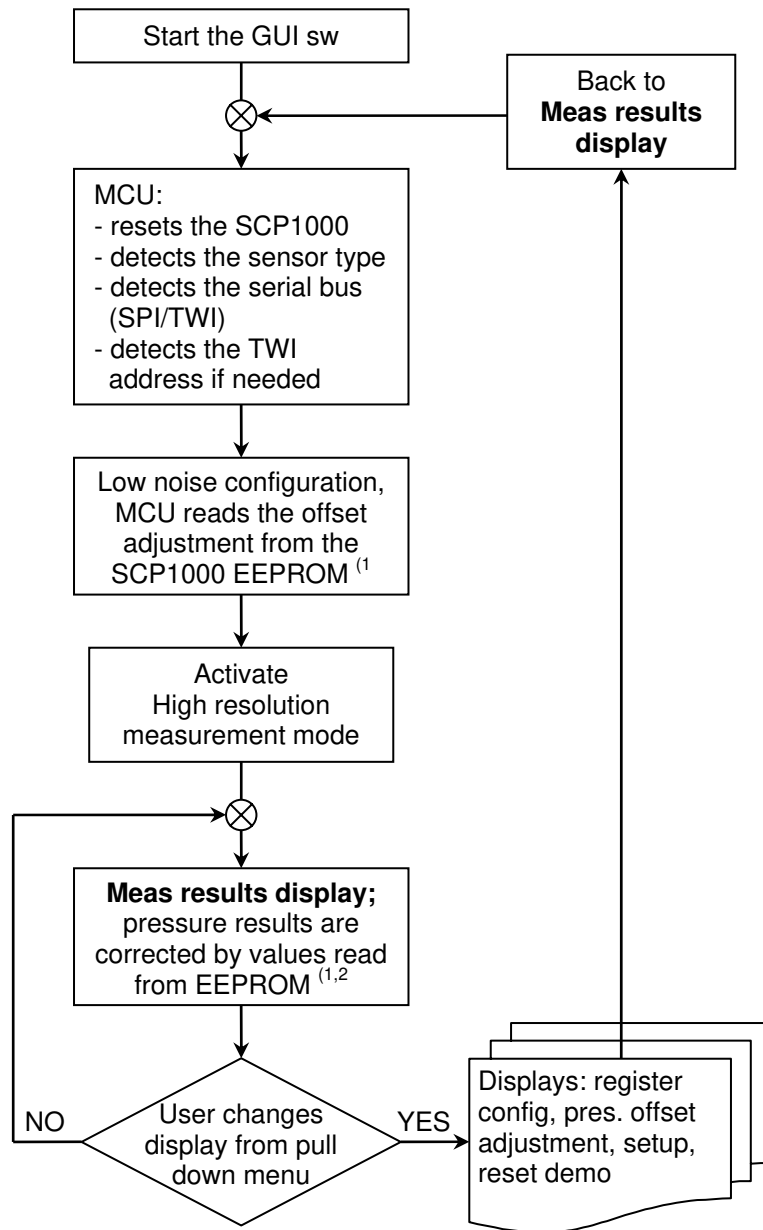

Figure 3. SCP1000 DEMO KIT Graphical User Interface.

Table 1. The numbered items in Figure 3.

Item	Description
1	Temperature display, [°C].
2	Exit software, [Esc]-button also.
3	Trigger measurement, visible only in low power measurement mode.
4	Scale pressure and temperature displays, press "Reset displays" to apply the changes.
5	Capture pressure data to file, browse for file name and location, then press "start data logging". Every data point is saved by default, the number of saved data points can be reduced.
6	Open / close the window extension with arrow button.
7	Pressure [mbar] and altitude [m] displays.
8	Select units: [mbar], [°C], [m] or [inHg], [F], [ft].
9	Selected sensor type and GUI software version number.
10	Averaging ON / OFF, number of samples for averaging.
11	Reset pressure and altitude displays, and apply new scaling parameters.
12	Pull down menu for SCP1000 measurement mode.
13	Pull down menu for GUI display mode.

The SCP1000 GUI software flow chart is presented in Figure 4 below.



- 1) more information on SCP1000 offset adjustment in Figure 9 and in TN48
- 2) If the pressure offset is not adjusted (the offset difference in EEPROM is zero), the MCU corrects the SCP1000 output value with zero value (e.g the SCP1000 raw output data)

Figure 4. SCP1000 GUI sw flow chart.

4.1 GUI software displays

The GUI software has four different display modes. All displays are presented below. Displays can be selected from the "Display" pull down menu (see #12 in Figure 3 and Table 1).

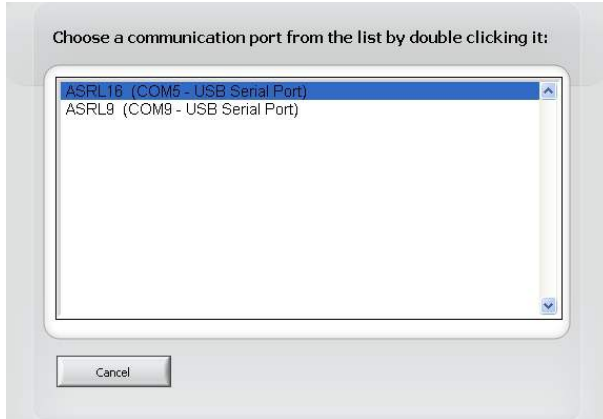

Figure 5. USB serial port selection pop-up window.

4.1.1 USB serial port selection

If more than one USB serial port devices (such as SCA3000 or SCP1000 demos) are connected to PC, user must double click on the correct **USB** serial port from the pop-up window (Figure 5). If user does not know the correct USB serial port number, please disconnect all other USB serial port devices from the PC and restart the GUI software.



Figure 6. Start up screen.

4.1.2 Start up and Reset demo

During the GUI software start up or after selecting "Reset demo" from the "Display" pull down menu, the MCU inside the SCP1000 demo detects automatically the correct sensor type and serial bus (SPI/TWI). Then the MCU reads the offset adjustment values from the SCP1000 internal EEPROM. SCP1000 is also initialised during the start up screen.

The MCU software version as well as SCP1000 sensor type is displayed in text field.

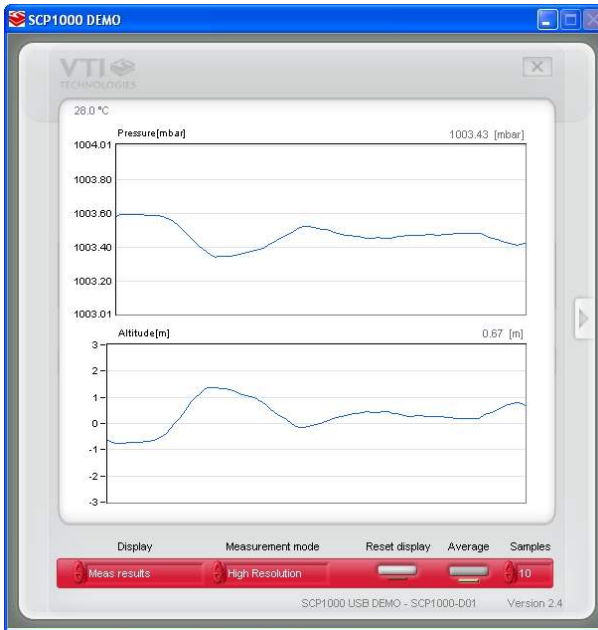

Figure 7. Meas results display.

4.1.3 Meas results

Meas results is a continuously scrolling graph for pressure [mbar] and altitude [m] data, see Figure 7. User can:

- Change the pressure and temperature scales, press "Reset display" to apply changes
- Change the averaging factor
- Set averaging ON/OFF. When averaging is OFF, the raw SCP1000 data is displayed
- Capture the pressure, altitude and temperature data in to file. The data is saved with the same averaging factor as it is displayed on the screen. By default every data point that is displayed on the screen are saved. Optionally user can save for example only every 10th data point displayed on the scrolling graph.
- Select the between the following units:
 - [mbar], [°C], [m] or
 - [inHg], [F], [ft]

Some of the actions/controls listed above can be found from the extension part of the window, which can be accessed by pressing the arrow button (see Figure 3 and Table 1).

The "Trig measurement" button is displayed in the extension part of the window only when the SCP1000 is in low power measurement mode.

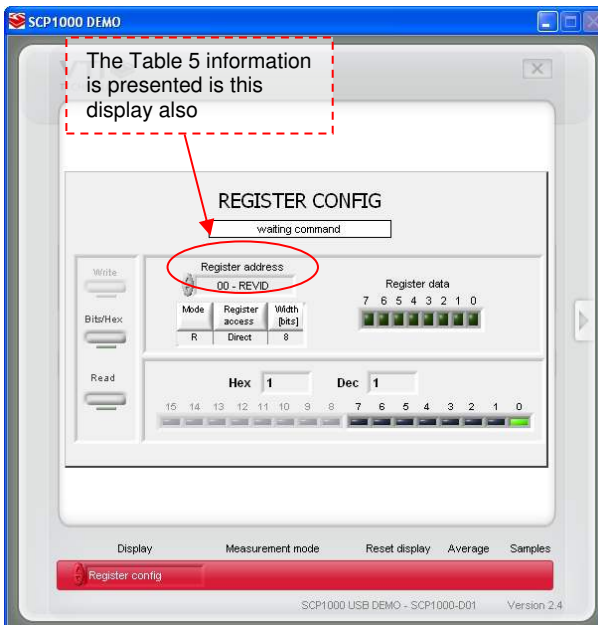

Figure 8. Register config display.

4.1.4 Register config

Register config display offers user access in to SCP1000 sensor internal registers. Registers can be read and written. The written data format can be changed between binary and hexadecimal by pressing the "Bits / Hex" button. Information of the selected register is displayed below the "Register address" pull down menu.

Please refer to the Table 5 and to the document "SCP1000 Product Family Specification 8260800" for more detailed information on SCP1000 registers.



Figure 9. Pressure offset adjustment display.

4.1.5 Pres offset adjustment

In pressure offset adjustment display user can adjust the absolute pressure offset value of the SCP1000. The MCU inside the demo box can read and write the pressure offset adjustment of the SCP1000 by using the SCP1000 internal EEPROM registers' USERDATA1 (0x29) and USERDATA (0x2A). The offset adjustment is performed in high resolution measurement mode. After SCP1000 offset is adjusted in this display, user can verify the calibration results in MEAS RESULTS display.

In offset adjustment display user can:

- Program the SCP1000 offset adjustment in to the SCP1000 internal EEPROM registers USERADATA1 and USERDATA2 ("Start offset adjustment" button)
- Read the current SCP1000 offset adjustment data from the two EEPROM registers ("Read current adjustment data" button)
- Reset the SCP1000 offset adjustment data by writing zeros in to two EEPROM registers ("Zero offset adjustment data" button)

Please refer to the following documents:

- "TN48 SCP1000 Pressure Offset Adjustment" for more detailed information on offset zeroing and offset adjustment bit level presentation that is used in this demo
- "SCP1000 Product Family Specification 8260800" for more detailed information SCP1000 EEPROM register reading/writing



Figure 10. Setup display.

4.1.6 Setup

Setup display presents the SCP1000 product type inside the demo box. The virtual serial COM port number in use can be viewed from "Serial port" display. This information is needed if the SCP1000 DEMO KIT is used without the GUI software, see further details from section 5.

In this example the SCP1000 DEMO KIT uses COM4 serial port.

Standard window frames can be enabled / disabled. In Figure 10 the window frames are disabled.

4.2 Uninstalling the GUI and USB driver

The GUI software and the USB driver (FTDI Serial Converter Driver) can be removed from Windows Control Panel Add/Remove Programs. Please notice that removing the FTDI Serial Converter Driver (USB driver) may affect on functionality of some other programs (such as SCA3000 demo kit GUI).

5 Using the SCP1000 demo without the GUI software

SCP1000 DEMO KIT can be used also without the GUI software. Serial communication between the SCP1000 USB demo and PC can be controlled with the GUI software or by Windows HyperTerminal software (serial virtual com port driver converts the USB demo to a COM port device).

5.1 Establishing the connection

After the SCP1000 DEMO KIT USB serial com port driver is installed, the HyperTerminal connection can be opened from SCP1000 demo CD-ROM or from:

→ Start → Programs → Accessories → Communications → HyperTerminal



The communication settings are presented in Table 2 below

Table 2. SCP1000 USB demo HyperTerminal communication settings.

Parameter	Value
Bits per second	38400
Data bits	8
Parity	None
Stop bits	1
Flow control	None

The correct COM port number depends on the PC and used USB port.

Please notice that GUI software and Windows HyperTerminal software can not be open at the same time. Follow the steps below to open the HyperTerminal connection:

1. Connect SCP1000 DEMO KIT with USB cable to PC
2. Open GUI software to see the correct COM port number (SETUP display, see Figure 10).
3. Close the GUI software.
4. Open the pre-configured Windows HyperTerminal software from the DEMO KIT CD-ROM: SCP1000_Demo_pre-configured_HyperTerminal_connection.ht
5. Type '*' (asterisk character), the SCP1000 DEMO KIT sends an info text to HyperTerminal (see Figure 11). If the HyperTerminal software is unable to connect the SCP1000 DEMO KIT or the info text does not appear,
 - Press **disconnect** ,
 - change the COM port number to correct from port **properties** ,
 - press **connect** ,
 - type '*' (asterisk character) to HyperTerminal
 until info text appears to HyperTerminal screen (see Figure 11).
6. After the info text appears on HyperTerminal, the connection between the SCP1000 DEMO KIT and HyperTerminal software is established.

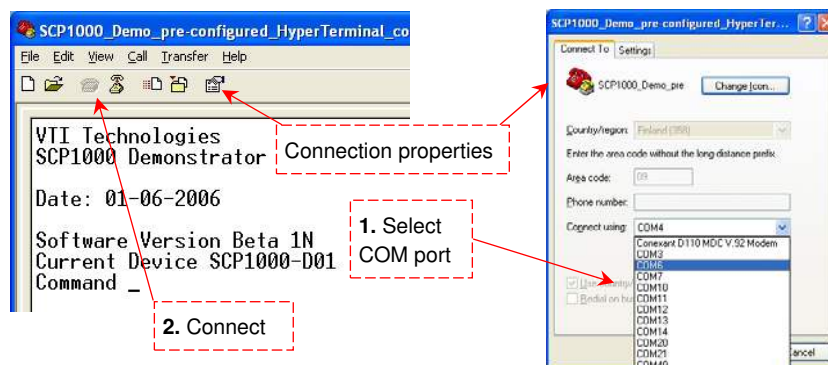

Figure 11. Windows HyperTerminal with SCP1000 demo info text.

5.2 Communication commands

After the HyperTerminal connection to SCP1000 USB demo is established, user can communicate with the SCP1000 in side the USB demo according to the communication flow chart presented in Figure 12 below. The register listing is presented in Table 5, see SCP1000 datasheet for further information.

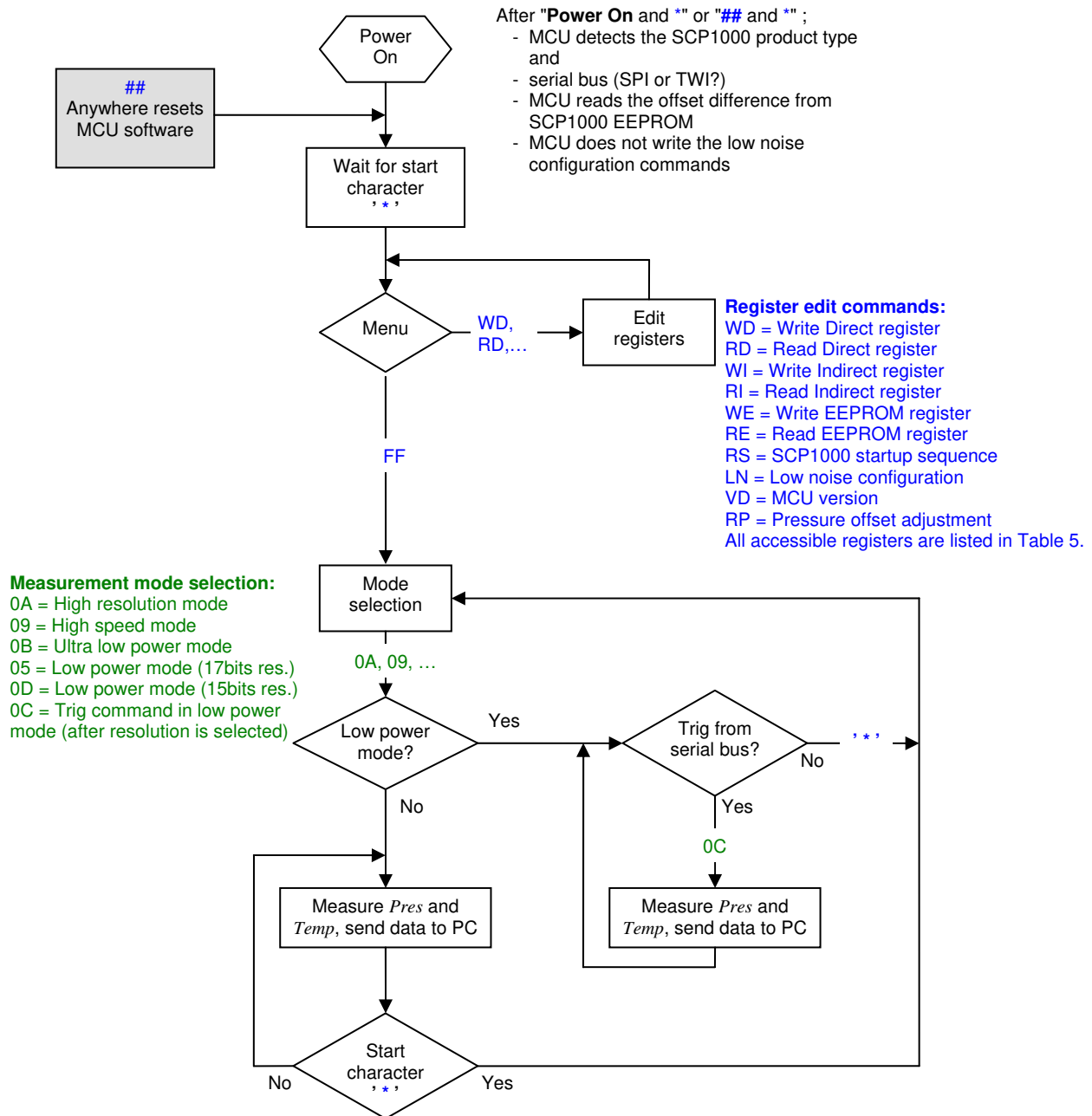

Figure 12. SCP1000 USB demo communication flow chart.

The pressure (*Pres*) and temperature (*Temp*) is sent to PC in [Pa] and in 10×[°C] format. Example of SCP1000 USB demo output data in high resolution mode below:

```

%102778 256$ →      pressure = 102778 Pa      temperature = 25.6 °C
%102779 257$ →      pressure = 102779 Pa      temperature = 25.7 °C
%102776 256$ →      pressure = 102776 Pa      temperature = 25.6 °C
  
```

Commands that are used to control the MCU of the USB demo are listed in Table 3 below.

Table 3. Commands for the USB demo MCU.

MCU Command	Command description
##	User can reset the MCU software and jump to the sw beginning by giving this command
*	Start / interrupt command
VD	Display MCU version details
FF	Set MCU software to measurement mode selection mode

Commands that are used to read/write the SCP1000 registers and to control the SCP1000 are listed in Table 4 below. The register address and data is always in hex format unless otherwise noted.

Table 4. Commands for the SCP1000.

SCP1000 command	Command description
WD	Write SCP1000 direct register
RD	Read SCP1000 direct register, register width is 08 or 16 (in dec format)
WI	Write SCP1000 indirect register, MCU performs the indirect write operation via 3 direct registers, please see section 3.3.1 in "SCP1000 Product Family Specification 8260800" for further details
RI	Read SCP1000 indirect register, MCU performs the indirect read operation via 3 direct registers, please see section 3.3.1 in "SCP1000 Product Family Specification 8260800" for further details
WE	Write SCP1000 EEPROM register, MCU performs the EEPROM write operation via 3 direct registers, please see section 3.4.1 in "SCP1000 Product Family Specification 8260800" for further details
RE	Read SCP1000 EEPROM register, MCU performs the EEPROM read operation via 3 direct registers, please see section 3.4.2 in "SCP1000 Product Family Specification 8260800" for further details
RS	Reset SCP1000: <ul style="list-style-type: none"> - set PD pin high, set PD pin low - perform the SCP1000 initialization status check, please see section 2.1.2.1 in "SCP1000 Product Family Specification 8260800" for further details
LN	Low noise configuration: <ul style="list-style-type: none"> - write 0x2D to direct register ADDPTR (0x02) - write 0x03 to direct register DATAWR (0x01) - write 0x02 to direct register OPERATION (0x03) Please see section 2.1.3 in "SCP1000 Product Family Specification 8260800" for further details
RP	Reference pressure (for pressure offset adjustment) Please see "TN48 SCP1000 Pressure Offset Adjustment" for further details.

All accessible SCP1000 registers are listed in Table 5 below, please refer to the document "SCP1000 Product Family Specification 8260800" for more detailed information on SCP1000 registers. The register address is always in hex format unless otherwise noted.

Table 5. List of SCP1000 direct and indirect access registers and EEPROM registers.

Address		Name	Description	Mode (R, W, RW)	Register access	Width [bits]
SPI	TWI					
	00	REVID	ASIC revision number	R	Direct	8
	01	DATAWR	Indirect register access data	RW	Direct	8
	02	ADDPTR	Indirect register access pointer	RW	Direct	8
	03	OPERATION	Operation register	RW	Direct	8
	04	OPSTATUS	Operation status	R	Direct	8
	06	RSTR	ASIC software reset	W	Direct	8
	07	STATUS	ASIC top-level status	R	Direct	8
1F	7F	DATARD8	Pressure output data (MSB) or 8 bit data read from EEPROM	R	Direct	8
20	80	DATARD16	Pressure output data (LSB) or 8-bit data read from indirect register	R	Direct	16
21	81	TEMPOUT	14-bit temperature output data	R	Direct	16
	00	CFG	Configuration register	RW	Indirect	8
	05	TWIADD	TWI address	W	Indirect	8
	09	CFG2	MISO configuration	RW	Indirect	8
	2D	MODTEST2	Noise level configuration	W	Indirect	8
	29	USERDATA1	User data	RW	EEPROM	8
	2A	USERDATA2	User data	RW	EEPROM	8
	2B	USERDATA3	User data	RW	EEPROM	8
	2C	USERDATA4	User data	RW	EEPROM	8

Register address in hex format.

RW – Read / Write register, R – Read only register.

6 Using two SCP1000 demo kits simultaneously

In some applications, such as air conditioning controlling or air flow measurements, differential pressure measurement is required. To support these kinds of applications two (or even more) SCP1000 demo kits can be used simultaneously on one PC.

In order to use two SCP1000 demo kits simultaneously follow the steps below:

1. Install the GUI software and USB driver as instructed above (see section 2).
2. Connect the 1st SCP1000 demo kit to PC.
3. Start the GUI software.
4. When the 1st SCP1000 demo kit and it's GUI software is running, connect the 2nd SCP1000 demo kit to PC.
5. Install the USB driver if required (the USB driver has to be installed separately for each USB port, see instructions in section 2).
6. Find the location of the SCP1000 demo kit GUI software exe-file (the default installation path is `C:\Program Files\SCP1000-USB-DEMO-VER.2.5`).
7. Copy the file "SCP1000-USB-DEMO-VER.2.5.exe" to other name (for example "Copy of SCP1000-USB-DEMO-VER.2.5.exe").
8. Start the GUI software for the 2nd SCP1000 demo kit by running the "Copy of SCP1000-USB-DEMO-VER.2.5.exe".

When both demo kits are connected to one PC, the SCP1000 data can be logged to separate files as instructed in section 4.1.3. If the both demo kits are used for data logging purposes, the data can be synchronized with the time stamp in the result file (time is from the PC's system clock). The Windows HyperTerminal can also be used with two SCP1000 demo kits (open own HyperTerminal connection for each demo kit).

Please notice, that the two demo kits may not work simultaneously if they are connected to PC via an USB hub (in such case, try connecting the demo kits directly to PC with out USB hub).

7 USB interface board circuit diagram

SCP1000 demo USB interface board circuit diagram is presented in following pages.

SCP1000_USB_DEMO_29450_a3.sch-2 - Mon Jun 19 17:23:59 2006

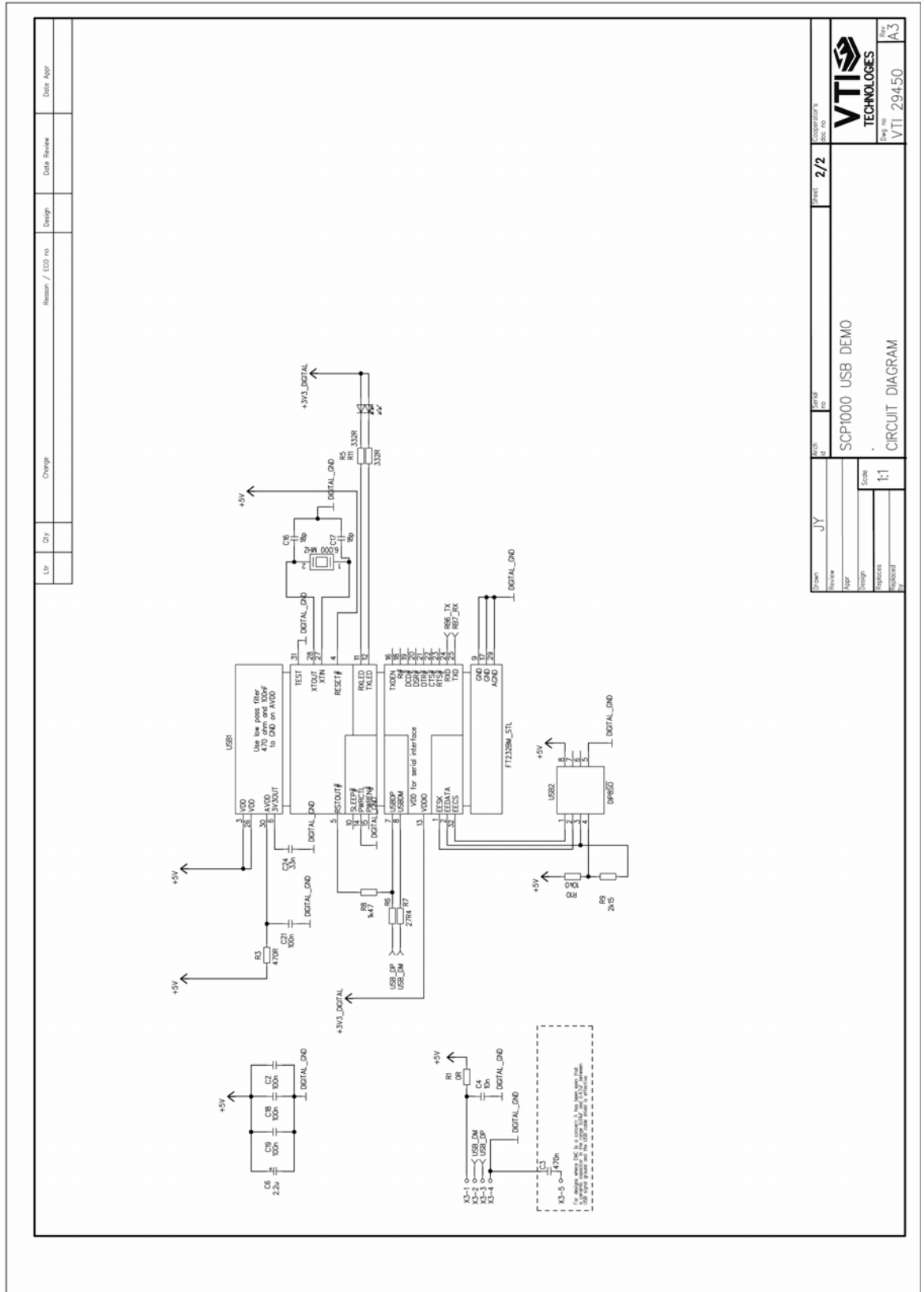

Figure 13. SCP1000 DEMO KIT USB interface board circuit diagram (sheet USB).

SCP1000_USB_DEMO_29450_a3.sch-1 - Mon Jun 19 17:23:58 2006

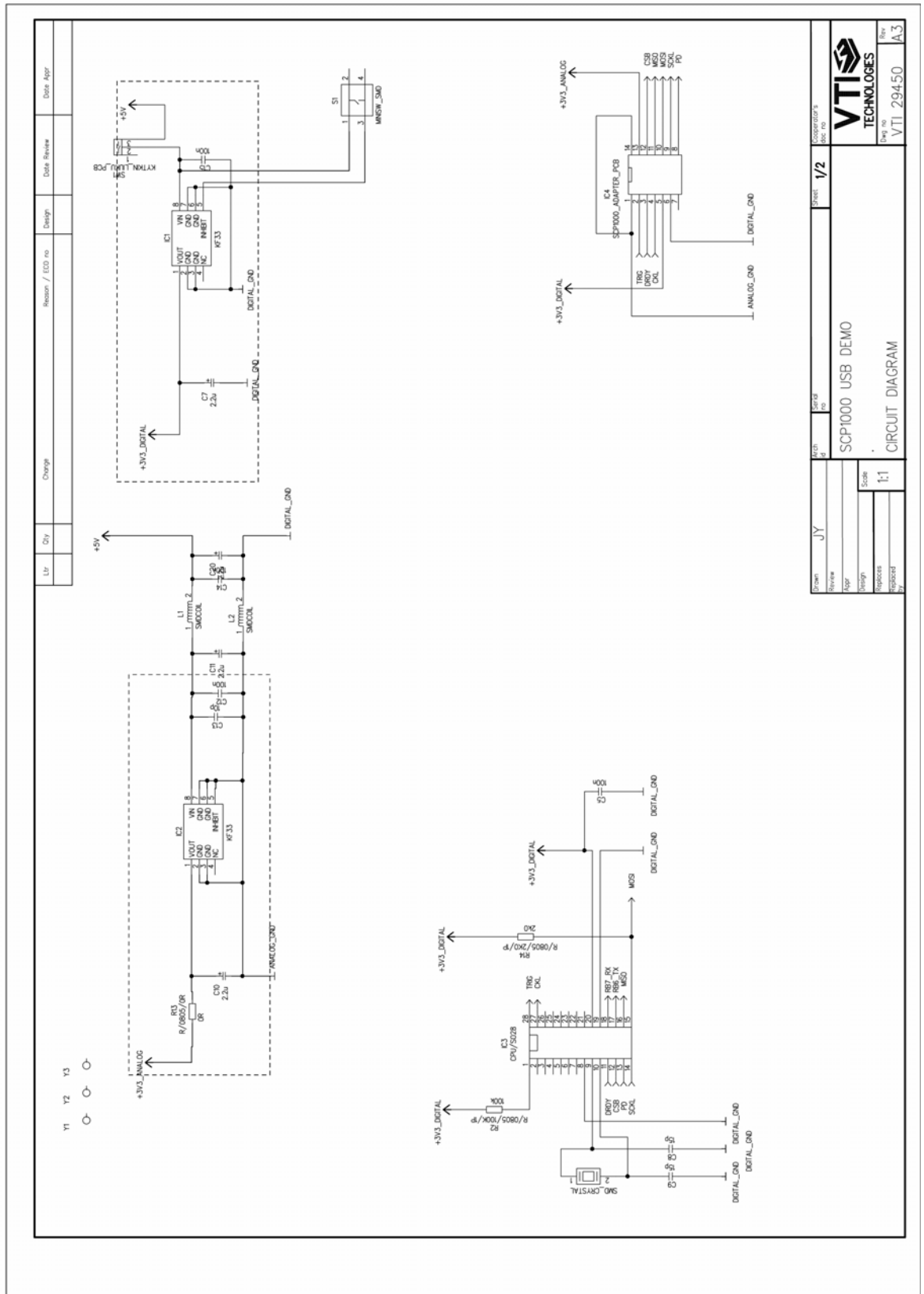

Figure 14. SCP1000 DEMO KIT USB interface board circuit diagram (sheet MCU).

9 Troubleshooting

Due to many PC environments, the interoperability can be limited. The SCP1000 DEMO KIT has been tested with DELL laptops (Latitude D600, D610, D410) and desktop PCs with Win2000 and WinXP operating system. If the SCP1000 DEMO KIT does not work properly or it's operation is limited, the following items may help to sort the problems out:

- Change the USB port where the demo is connected
- SCP1000 demo may not work properly if your PC has multiple USB serial ports installed. Please remove all other USB serial port devices (including the SCA3000 demo).
- Close Windows HyperTerminal software, if you have used it.
- Re-install the FTDI USB Serial port driver:
 1. Unplug the demo from PC
 2. Uninstall the "FTDI USB Serial Converter Drivers" from "Control Panel" → "Add/Remove programs".
 3. Connect the SCP1000 DEMO KIT to PC and re-install the drivers as Windows detects the demo, see section 2.

10 Document Revision History

Version	Date	Change Description
0.01	30.08.2006	First release for GUI version 2.4, Document "TN49 SCP1000 register access with USB-demo" is included in to this document
0.02	08.09.2006	GUI software updated to version 2.5 (user can select the used units in 'Meas results' display)
0.03	05.02.2007	Section "6 Using two SCP1000 demo kits simultaneously" added.

11 Contact Information

Finland

(head office)

VTI Technologies Oy
P.O. Box 27
Myllynkivenkuja 6
FI-01621 Vantaa
Finland
Tel. +358 9 879 181
Fax +358 9 8791 8791
E-mail: sales@vti.fi

Germany

VTI Technologies Oy
Branch Office Frankfurt
Rennbahnstrasse 72-74
D-60528 Frankfurt am Main,
Germany
Tel. +49 69 6786 880
Fax +49 69 6786 8829
E-mail: sales.de@vti.fi

USA

VTI Technologies, Inc.
One Park Lane Blvd.
Suite 804 - East Tower
Dearborn, MI 48126
USA
Tel. +1 313 425 0850
Fax +1 313 425 0860
E-mail: sales@vtitechnologies.com

Japan

VTI Technologies Oy
Tokyo Office
Tokyo-to, Minato-ku 2-7-16
Bureau Toranomom 401
105-0001
Japan
Tel. +81 3 6277 6618
Fax +81 3 6277 6619
E-mail: sales.japan@vti.fi

China

VTI Technologies Shanghai Office
6th floor, Room 618
780 Cailun Lu
Pudong New Area
201203 Shanghai
P.R. China
Tel. +86 21 5132 0417
Fax +86 21 513 20 416
E-mail: sales.china@vti.fi

To find out your local sales
representative visit www.vti.fi