

Evaluating the ADMV4640 10.7 GHz to 12.7 GHz, Microwave Downconverter

FEATURES

- ▶ Fully featured evaluation board for the ADMV4640
- ▶ On-board **SDP-S** connector for SPI control
- ▶ Simplified power-up with on-board LDO regulators
- ▶ 5 V operation
- ▶ **ACE** software interface for SPI control

EVALUATION KIT CONTENTS

- ▶ EVAL-ADMV4640Z evaluation board
- ▶ Mini USB to USB cable
- ▶ **SDP-S** controller board

EQUIPMENT NEEDED

- ▶ 5 V dc power supply
- ▶ DC clips
- ▶ RF signal generator
- ▶ Spectrum analyzer
- ▶ Power supply cables, 2.92 mm coaxial cables
- ▶ PC for **ACE** software

DOCUMENTS NEEDED

- ▶ ADMV4640 data sheet

EVALUATION BOARD PHOTOGRAPH

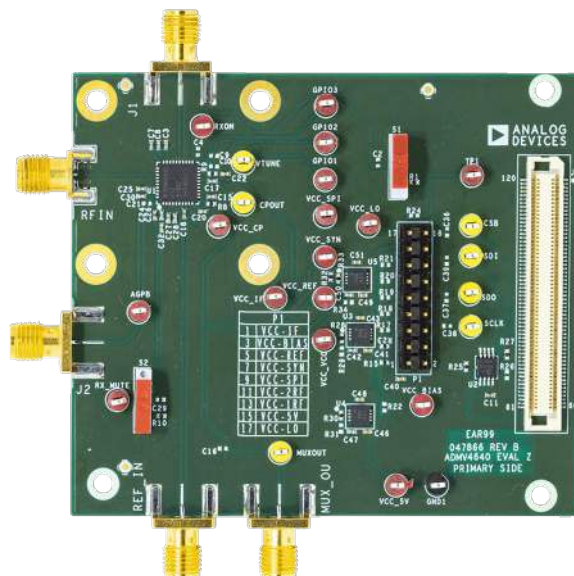

Figure 1.

SOFTWARE NEEDED

- ▶ **ACE** software
- ▶ ADMV4640 plugins

GENERAL DESCRIPTION

The EVAL-ADMV4640Z evaluation board incorporates the ADMV4640, low dropout (LDO) regulators, and the **EVAL-SDP-CS1Z (SDP-S)** controller board to allow simplified, efficient evaluation of the ADMV4640. The **SDP-S** controller board allows the configuration of the ADMV4640 register map through the **Analysis, Control, Evaluation (ACE)** software. The LDO regulators allow the EVAL-ADMV4640Z to be powered by a 5 V single supply.

The ADMV4640 is a microwave downconverter optimized for various satellite communication (SATCOM) user terminals operating in the 10.7 GHz to 12.7 GHz frequency range.

The ADMV4640 downconverter comes in a compact, thermally enhanced, 6 mm × 6 mm, 40-lead frame chip scale package (LFCSP). The ADMV4640 operates over the -40°C to +85°C case temperature range.

For full details on the ADMV4640, see the **ADMV4640** data sheet, which must be consulted in conjunction with this user guide when using the EVAL-ADMV4640Z.

TABLE OF CONTENTS

Features.....	1	Installing the ACE Software and ADMV4640	
Evaluation Kit Contents.....	1	Plugins and Drivers.....	4
Equipment Needed.....	1	Configuring the Board.....	4
Documents Needed.....	1	ADMV4640 Block Diagram and Functions.....	5
Software Needed.....	1	Evaluation Board Schematics.....	7
General Description.....	1	Ordering Information.....	9
Evaluation Board Photograph.....	1	Bill of Materials.....	9
Evaluation Board Hardware.....	3	Notes.....	10
Evaluation Board Software Quick Start Procedures.....	4		

REVISION HISTORY

7/2022—Revision A: Initial Version

.....

EVALUATION BOARD HARDWARE

The EVAL-ADMV4640Z comes with an on-board [ADMV4640](#) chip. When evaluating the ADMV4640 device, connect the IF input to an RF signal generator. The EVAL-ADMV4640Z runs on a 5 V dc supply. Connect the 5 V dc supply to the VCC_5V test point, and the ground to the GND1 test point.

Figure 2 shows the block diagram of the EVAL-ADMV4640Z lab bench setup.

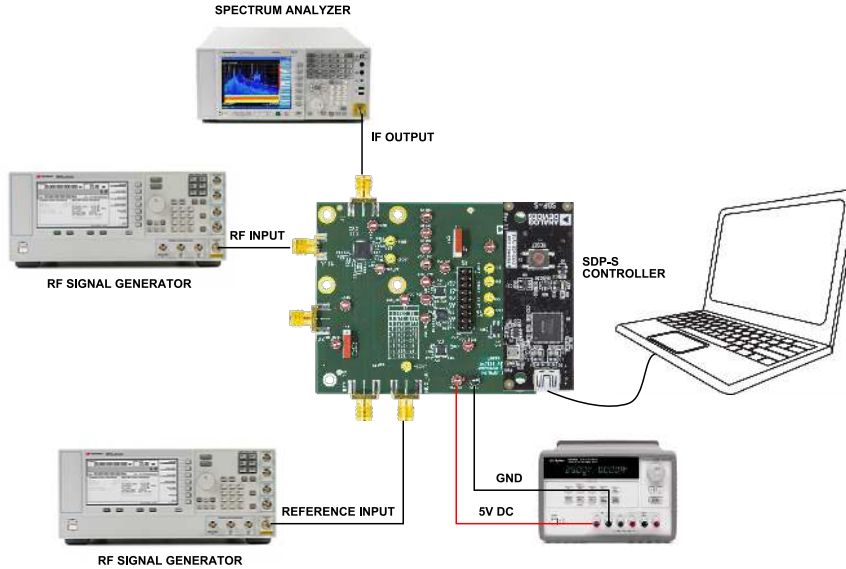

Figure 2. Lab Bench Setup

012

EVALUATION BOARD SOFTWARE QUICK START PROCEDURES

INSTALLING THE ACE SOFTWARE AND ADMV4640 PLUGINS AND DRIVERS

The EVAL-ADMV4640Z software uses the Analog Devices, Inc., ACE software. Ensure that the ACE software is installed before setting up or using the EVAL-ADMV4640Z. For instructions on how to install and use the ACE software, go to www.analog.com/ACE.

If the ACE software has already been installed on the PC, ensure that it is the latest version that is shown on the www.analog.com/ACE page.

1. Install the latest version of ACE software. In the ACE Setup window, ensure that the SDP Drivers, LRF Drivers, and NET 4.8 installations are selected (see Figure 3). Then click Install.

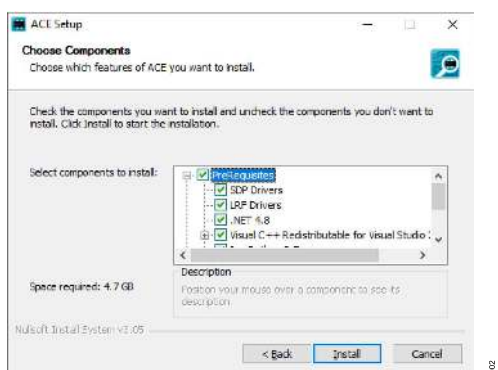

Figure 3. Drivers to Install with ACE Software

2. Open the ACE software and the EVAL-ADMV4640Z plugin appears (see Figure 4).

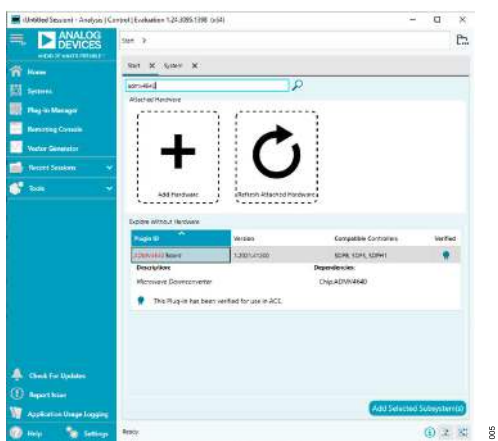

Figure 4. EVAL-ADMV4640Z Plugin Window

CONFIGURING THE BOARD

To set up the EVAL-ADMV4640Z, take the following steps:

1. Connect the SDP-S controller board to the J3 connectors on the EVAL-ADMV4640Z.
2. Connect the USB cable to the PC and then to the SDP-S controller board.

3. Connect the 5 V clip lead on the power supply to the red VCC_5V test point on the EVAL-ADMV4640Z, and connect the GND clip lead on the power supply to the black GND1 test point. The power supply current limiting must be set to approximately 500 mA.
4. Open the ACE software. The ADMV4640 Board plugin appears in the Attached Hardware section. Double-click the EVAL-ADMV4640Z plugin. The ADMV4640 Board tab opens (see Figure 5).
5. Click off the Poll Device button and double-click the ADMV4640 button (see Figure 5).

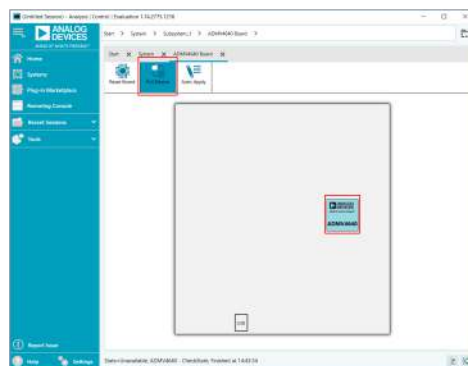

Figure 5. ADMV4640 Board Tab

6. The ADMV4640 block diagram appears (see Figure 6).
7. Click the Initialization & Optimization button in the ADMV4640 block diagram to initialize the device before operation.

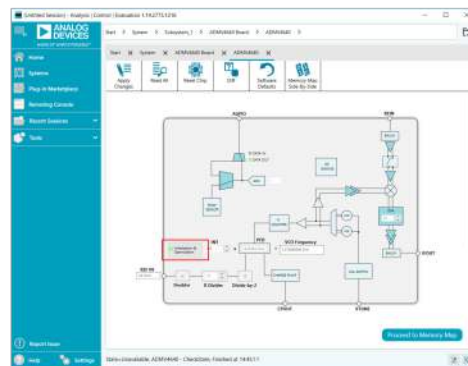

Figure 6. ADMV4640 Block Diagram in the ACE Software

8. To set up the RF, use the following settings and measure the output at the IFOUT port:
 - ▶ REF_IN port: reference frequency = 25 MHz, 3 dBm, and dc block is needed.
 - ▶ RF input: RF frequency = 12 GHz, -30 dBm.
 - ▶ The gain is at minimum attenuation. Note that the chip temperature is higher than 25°C for the reference frequency and RF frequency conditions and there is part to part variation. The gain may be lower than the typical specifications in the ADMV4640 data sheet.

ADMV4640 BLOCK DIAGRAM AND FUNCTIONS

The ADMV4640 block diagram user interface with labels is shown in Figure 7, and Table 1 describes the functionality of each block.

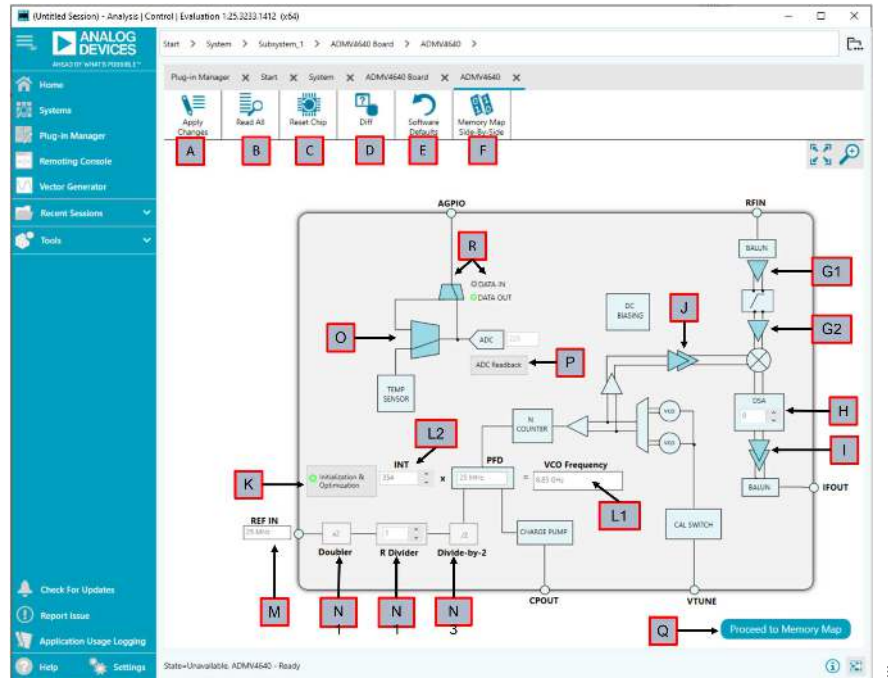

Figure 7. ADMV4640 Block Diagram with Labels

Table 1. ADMV4640 Block Diagram Label Functions (See Figure 7)

Label	Function
A	Click Apply Changes to apply all register values to the device. If Auto Apply is highlighted in the ADMV4640 Board tab, the Apply Changes feature continuously runs every few seconds, and does not need to be clicked to apply or read back the block diagram settings.
B	Click Read All to read back all SPI registers of the device.
C	Click Rest Chip to reset the ADMV4640 chip.
D	Click Diff to show registers that are different on the device.
E	Click Software Defaults to load the software defaults on to the device, and then click Apply Changes .
F	Click Memory Map Side-By-Side to open the memory map.
G1	Click the LNA Stage 1 Enable switch (represented by Label G1) to set the LNASTG1_BIAS_CONTROL bit (Bit 2, Register 0x100). When the LNA Stage 1 Enable switch is highlighted, the LNASTG1_BIAS_CONTROL bit is enabled. When the LNA Stage 1 Enable switch is not highlighted, the LNASTG1_BIAS_CONTROL bit is disabled.
G2	Click the LNA Stage 2 Enable switch (represented by Label G2) to set the LNASTG2_BIAS_CONTROL bit (Bit 3, Register 0x100). When the LNA Stage 2 Enable switch is highlighted, the LNASTG2_BIAS_CONTROL bit is enabled. When the LNA Stage 2 Enable switch is not highlighted, the LNASTG2_BIAS_CONTROL bit is disabled.
H	Use the DSA scroll to choose a value, or enter a value in the text box to set the SEL_DSA_ATTEN bit (Bit[4:0], Register 0x300).
I	Click the IF Amp Enable switch (represented by Label I) to set the AMPIF_BIAS_CONTROL bit (Bit 0, Register 0x100). When the IF Amp Enable switch is highlighted, the AMPIF_BIAS_CONTROL bit is enabled. When the IF Amp Enable switch is not highlighted, the AMPIF_BIAS_CONTROL bit is disabled.
J	Click the LO Amp Enable (represented by Label J) switch to set the AMPLO_BIAS_CONTROL bit (Bit 1, Register 0x100). When the LO Amp Enable switch is highlighted, the AMPLO_BIAS_CONTROL bit is enabled. When the LO Amp Enable switch is not highlighted, the AMPLO_BIAS_CONTROL bit is disabled.
K	Click Initialization & Optimization to initialize and lock the synthesizer.
L1	Enter a value in the VCO Frequency text box to set the VCO frequency. The INT value (Label L2) is calculated based on the VCO Frequency value. Alternatively, change the INT value to calculate the VCO Frequency value.
L2	Use the INT scroll to choose a value, or enter a value in the text box to set the 16-bit integer value (Register 0x200, Register 0x201) of the PLL. The VCO Frequency value is calculated based on the INT value. Alternatively, change the VCO Frequency value to calculate the INT value.

ADMV4640 BLOCK DIAGRAM AND FUNCTIONS

Table 1. ADMV4640 Block Diagram Label Functions (See Figure 7)

Label	Function
M	Enter a value in the REF IN text box to set the reference frequency.
N1	Click the Doubler switch to set the DOUBLER_EN bit (Bit 3, Register 0x20E). When the Doubler switch is highlighted, the DOUBLER_EN bit is enabled. When the Doubler switch is not highlighted, the DOUBLER_EN bit is disabled.
N2	Use the R Divider scroll to choose a value, or enter a value in the text box to change the R divider value (Bit[4:0], Register 0x20C).
N3	Click the Divide-by-2 switch to set the RDIV2_EN (Bit 0, Register 0x20E). When the Divide-by-2 switch is highlighted, the RDIV2_EN bit is enabled. When the Divide-by-2 switch is not highlighted, the RDIV2_EN bit is disabled.
O	Click the AMUX switch (represented by Label O) to set the SEL_AMUX bit (Bit[2:0], Register 0x301). There are two options for AMUX, AGPIO and temperature sensor (PTAT).
P	ADC blocks. Click Read from ADC to readback ADC values. See the ADMV4640 data sheet for further details.
Q	Click Proceed to Memory Map to open the ADMV4640 memory map (see Figure 8).
R	Click the AGPIO switch (represented by Label F) to set the SEL_AGPIO bit (Bit 3, Register 0x301). When the AGPIO switch is set to the right, the SEL_AGPIO bit is disabled and the AGPIO pin is used as data output. When the AGPIO switch is set to the left, the SEL_AGPIO bit is enabled and the AGPIO pin is used as external data input. See the ADMV4640 data sheet for further details.

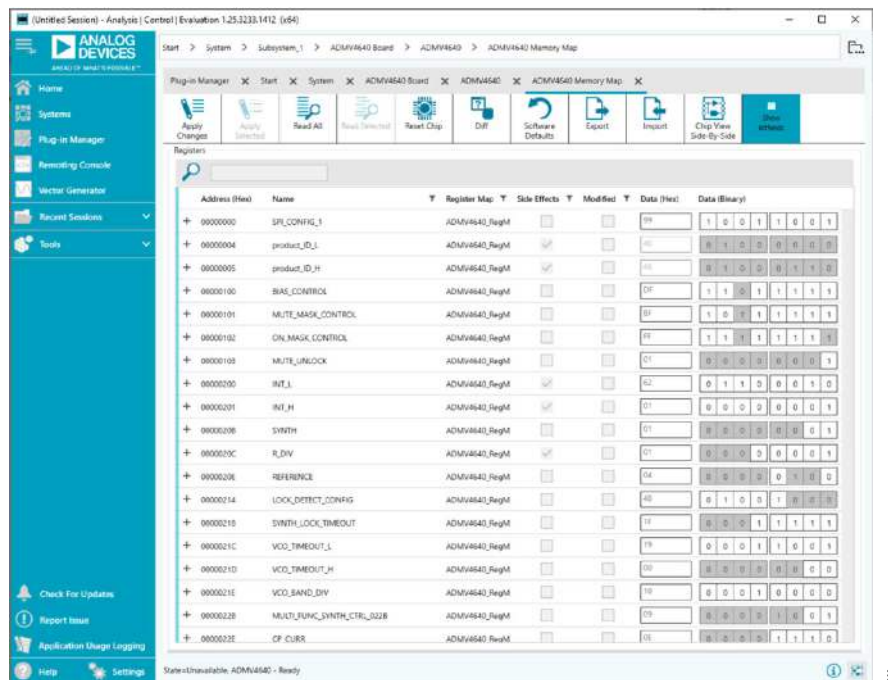

Figure 8. ADMV4640 Memory Map in the ACE Software

EVALUATION BOARD SCHEMATICS

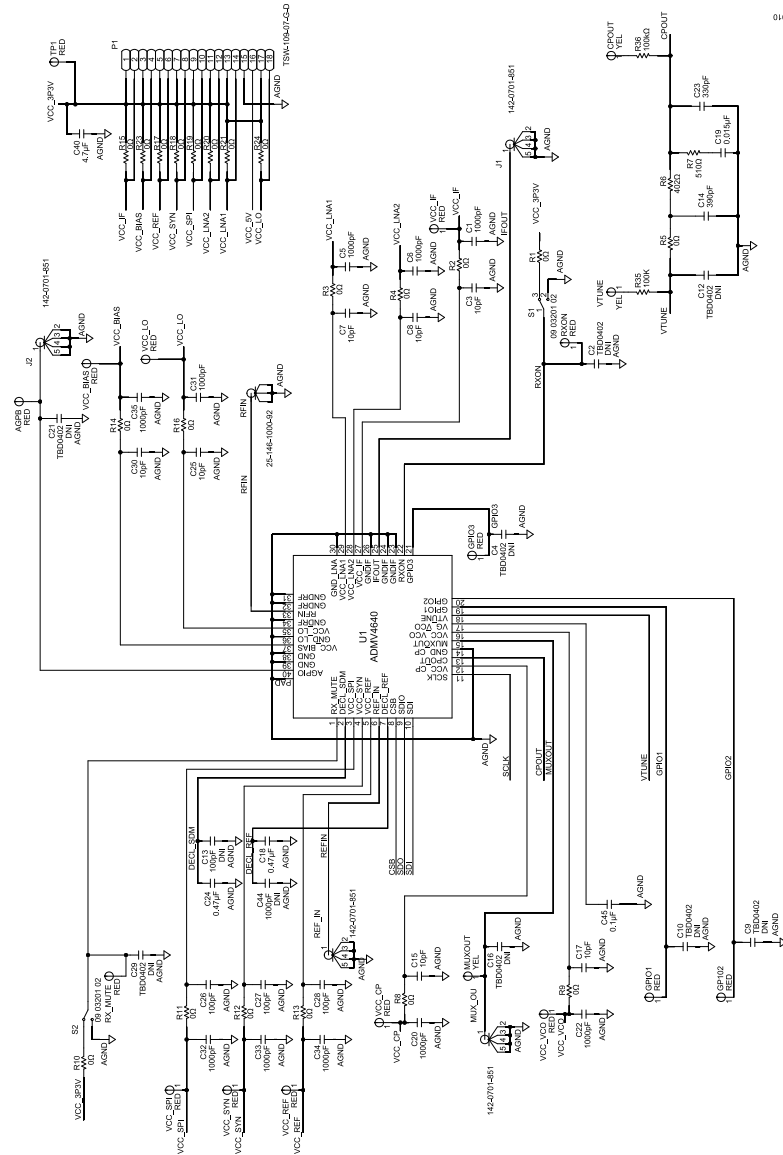

Figure 9. EVAL-ADMV4640Z Schematic, Page 1

EVALUATION BOARD SCHEMATICS

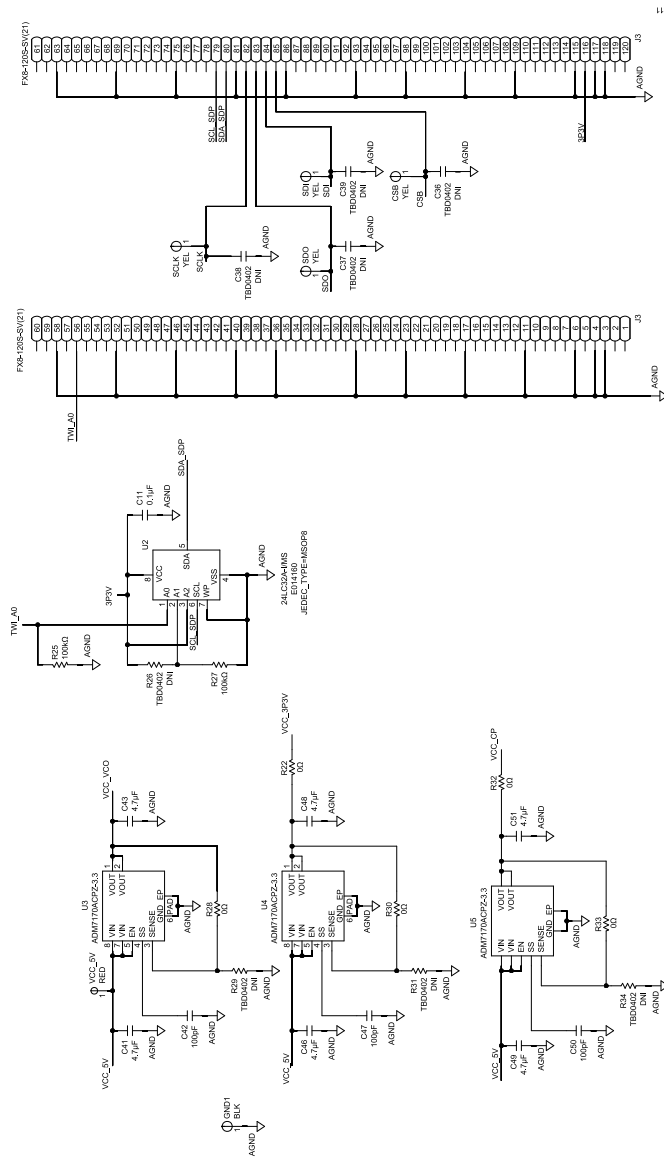

Figure 10. EVAL-ADMV4640Z Schematic, Page 2

ORDERING INFORMATION

BILL OF MATERIALS

Table 2.

Qty	Reference Designators	Description	Manufacturer	Part Number
16	AGPB, GP102, GPIO1, GPIO3, RXON, RX_MUTE, TP1, VCC_5V, VCC_BIAS, VCC_CP, VCC_IF, VCC_LO, VCC_REF, VCC_SPI, VCC_SYN, VCC_VCO	Test points, red	Components Corporation	TP-104-01-02
10	C1, C5, C6, C20, C22, C31 to C35	1000 pF ceramic capacitors	Murata	GRM1555C1H102JA01
2	C11, C45	0.1 μ F ceramic capacitors	American Technical Ceramics	530L104KT16T
1	C14	390 pF ceramic capacitor	Murata	GCM1555C1H391JA16D
7	C3, C7, C8, C15, C17, C25, C30	10 pF ceramic capacitors	Yageo	CC0402JRN0P09B100
2	C18, C24	0.47 μ F ceramic capacitors	Samsung	dCL05A474KA5NNNC
1	C19	0.015 μ F ceramic capacitor	Murata	GCM155R71H153JA55D
1	C23	330 pF ceramic capacitor	Murata	GCM1555C1H331JA16D
6	C26, C27, C28, C42, C47, C50	100 pF ceramic capacitors	TDK	C1005NP01H101J050BA
7	C40, C41, C43, C46, C48, C49, C51	4.7 μ F ceramic capacitors	Murata	GRM155R60J475ME87D
14	C2, C4, C9, C10, C12, C13, C16, C21, C29, C36 to C39, C44	Do not install	TBD0402	TBD0402
7	CPOUT, CSB, MUXOUT, SCLK, SDI, SDO, VTUNE	Test points, yellow	Components Corporation	TP-104-01-04
1	GND1	Test point, black	Components Corporation	TP-104-01-00
4	J1, J2, MUX_OU, REF_IN	SMA connectors	Johnson	142-0701-851
1	J3	120-pin connector	Hirose Electric	FX8-120S-SV(21)
1	P1	18-pin head connector	Samtec Inc.	TSW-109-07-G-D
26	R1 to R5, R8 to R24, R28, R30, R32, R33	0 Ω chip resistors	Panasonic	ERJ-2GE0R00X
2	R25, R27	100 k Ω chip resistors	Panasonic	ERJ-2RKF1003X
2	R35, R36	100 k Ω chip resistors	Vishay	CRCW0402100KJNED
1	R6	402 k Ω chip resistor	Panasonic	ERJ-2RKF4020X
1	R7	510 Ω chip resistor	Yageo	RC0402FR-07510RL
4	R26, R29, R31, R34	Do not install	TBD0402	TBD0402
1	RFIN	2.92 mm RF connector	SRI Connector Gage Company	25-146-1000-92
2	S1, S2	Switches	EAO	09-03-201-02
1	U1	ADMV4640	Analog Devices	ADMV4640BCPZN
1	U2	EEPROM	Microchip Technology	24LC32A-I/MS
3	U3, U4, U5	LDO regulators	Analog Devices	ADM7170ACPZ-3.3-R7

ORDERING INFORMATION**NOTES****ESD Caution**

ESD (electrostatic discharge) sensitive device. Charged devices and circuit boards can discharge without detection. Although this product features patented or proprietary protection circuitry, damage may occur on devices subjected to high energy ESD. Therefore, proper ESD precautions should be taken to avoid performance degradation or loss of functionality.

Legal Terms and Conditions

By using the evaluation board discussed herein (together with any tools, components documentation or support materials, the "Evaluation Board"), you are agreeing to be bound by the terms and conditions set forth below ("Agreement") unless you have purchased the Evaluation Board, in which case the Analog Devices Standard Terms and Conditions of Sale shall govern. Do not use the Evaluation Board until you have read and agreed to the Agreement. Your use of the Evaluation Board shall signify your acceptance of the Agreement. This Agreement is made by and between you ("Customer") and Analog Devices, Inc. ("ADI"), with its principal place of business at Subject to the terms and conditions of the Agreement, ADI hereby grants to Customer a free, limited, personal, temporary, non-exclusive, non-sublicensable, non-transferable license to use the Evaluation Board FOR EVALUATION PURPOSES ONLY. Customer understands and agrees that the Evaluation Board is provided for the sole and exclusive purpose referenced above, and agrees not to use the Evaluation Board for any other purpose. Furthermore, the license granted is expressly made subject to the following additional limitations: Customer shall not (i) rent, lease, display, sell, transfer, assign, sublicense, or distribute the Evaluation Board; and (ii) permit any Third Party to access the Evaluation Board. As used herein, the term "Third Party" includes any entity other than ADI, Customer, their employees, affiliates and in-house consultants. The Evaluation Board is NOT sold to Customer; all rights not expressly granted herein, including ownership of the Evaluation Board, are reserved by ADI. CONFIDENTIALITY. This Agreement and the Evaluation Board shall all be considered the confidential and proprietary information of ADI. Customer may not disclose or transfer any portion of the Evaluation Board to any other party for any reason. Upon discontinuation of use of the Evaluation Board or termination of this Agreement, Customer agrees to promptly return the Evaluation Board to ADI. ADDITIONAL RESTRICTIONS. Customer may not disassemble, decompile or reverse engineer chips on the Evaluation Board. Customer shall inform ADI of any occurred damages or any modifications or alterations it makes to the Evaluation Board, including but not limited to soldering or any other activity that affects the material content of the Evaluation Board. Modifications to the Evaluation Board must comply with applicable law, including but not limited to the RoHS Directive. TERMINATION. ADI may terminate this Agreement at any time upon giving written notice to Customer. Customer agrees to return to ADI the Evaluation Board at that time. LIMITATION OF LIABILITY. THE EVALUATION BOARD PROVIDED HEREUNDER IS PROVIDED "AS IS" AND ADI MAKES NO WARRANTIES OR REPRESENTATIONS OF ANY KIND WITH RESPECT TO IT. ADI SPECIFICALLY DISCLAIMS ANY REPRESENTATIONS, ENDORSEMENTS, GUARANTEES, OR WARRANTIES, EXPRESS OR IMPLIED, RELATED TO THE EVALUATION BOARD INCLUDING, BUT NOT LIMITED TO, THE IMPLIED WARRANTY OF MERCHANTABILITY, TITLE, FITNESS FOR A PARTICULAR PURPOSE OR NON-INFRINGEMENT OF INTELLECTUAL PROPERTY RIGHTS. IN NO EVENT WILL ADI AND ITS LICENSORS BE LIABLE FOR ANY INCIDENTAL, SPECIAL, INDIRECT, OR CONSEQUENTIAL DAMAGES RESULTING FROM CUSTOMER'S POSSESSION OR USE OF THE EVALUATION BOARD, INCLUDING BUT NOT LIMITED TO LOST PROFITS, DELAY COSTS, LABOR COSTS OR LOSS OF GOODWILL. ADI'S TOTAL LIABILITY FROM ANY AND ALL CAUSES SHALL BE LIMITED TO THE AMOUNT OF ONE HUNDRED US DOLLARS (\$100.00). EXPORT. Customer agrees that it will not directly or indirectly export the Evaluation Board to another country, and that it will comply with all applicable United States federal laws and regulations relating to exports. GOVERNING LAW. This Agreement shall be governed by and construed in accordance with the substantive laws of the Commonwealth of Massachusetts (excluding conflict of law rules). Any legal action regarding this Agreement will be heard in the state or federal courts having jurisdiction in Suffolk County, Massachusetts, and Customer hereby submits to the personal jurisdiction and venue of such courts. The United Nations Convention on Contracts for the International Sale of Goods shall not apply to this Agreement and is expressly disclaimed.

