

Absolute maximum ratings

($T_a=25^\circ\text{C}$)

Symbol	Ratings		Unit
	NPN	PNP	
V_{CBO}	60	-60	V
V_{CEO}	60	-60	V
V_{EBO}	6	-6	V
I_c	10	-10	A
I_{CP}	15 ($PW \leq 1\text{ms}, D_u \leq 50\%$)	-15 ($PW \leq 1\text{ms}, D_u \leq 50\%$)	A
I_{FEC}	—	-10	A
$I_{FEC P}$	—	-15	A
I_B	0.5	-0.5	A
P_T	5 ($T_a=25^\circ\text{C}$)		W
	35 ($T_c=25^\circ\text{C}$)		
V_{ISO}	1000 (Between fin and lead pin, AC)		V_{rms}
T_j	150		$^\circ\text{C}$
T_{stg}	-40 to +150		$^\circ\text{C}$
θ_{j-c}	3.57		$^\circ\text{C/W}$

Equivalent circuit diagram

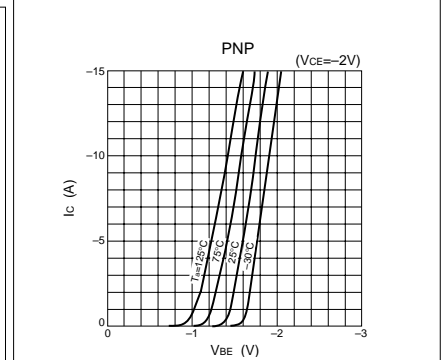
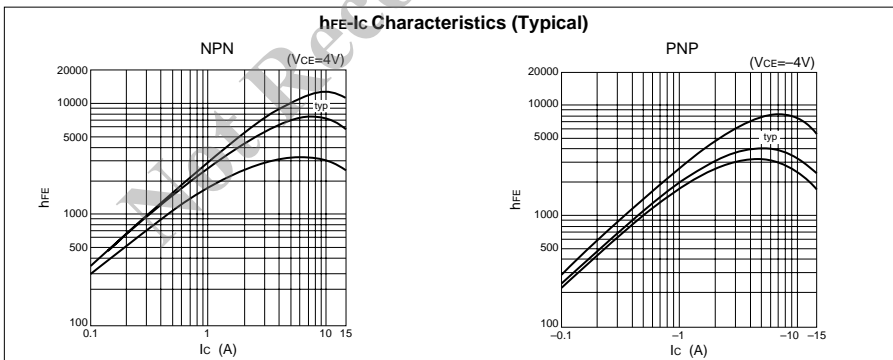
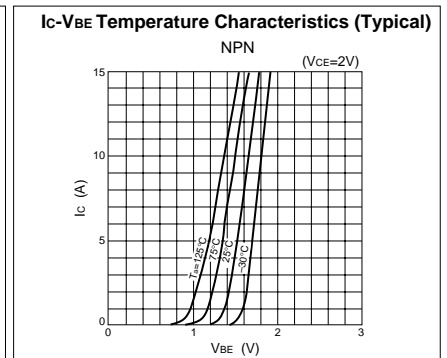
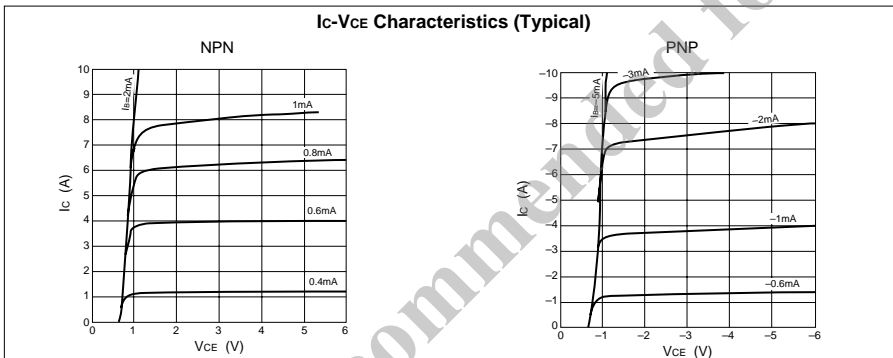
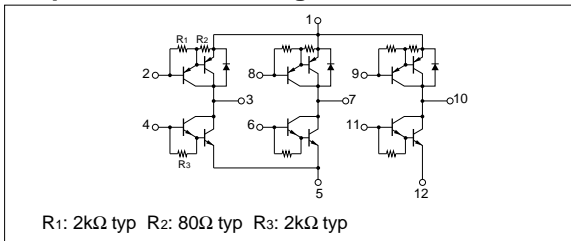

Electrical characteristics

($T_a=25^\circ\text{C}$)

Symbol	NPN					PNP				
	Specification			Unit	Conditions	Specification			Unit	Conditions
	min	typ	max			min	typ	max		
I_{CBO}			10	μA	$V_{CB}=60\text{V}$			-10	μA	$V_{CB}=-60\text{V}$
I_{EBO}			10	μA	$V_{EB}=6\text{V}$			-10	mA	$V_{EB}=-6\text{V}$
V_{CEO}	60			V	$I_C=10\text{mA}$	-60			V	$I_C=-10\text{mA}$
h_{FE}	2000	5000	12000		$V_{CE}=4\text{V}, I_C=6\text{A}$	2000	5000	12000		$V_{CE}=-4\text{V}, I_C=-6\text{A}$
$V_{CE(sat)}$			1.5	V	$I_C=6\text{A}, I_B=12\text{mA}$			-1.5	V	$I_C=-6\text{A}, I_B=-12\text{mA}$
$V_{BE(sat)}$			2.0	V				-2.0	V	
V_{FEC}		-		V				2.0	V	$I_{FEC}=-6\text{A}$
t_{rr}		-		μs			4.0		μs	$I_{FEC}=\pm 0.5\text{A}$
t_{on}		0.6		μs	$V_{CC}=\pm 24\text{V}, I_C=6\text{A}, I_{B1}=-I_{B2}=12\text{mA}$		0.7		μs	$V_{CC}=\pm 24\text{V}, I_C=-6\text{A}, I_{B1}=-I_{B2}=-12\text{mA}$
t_{stg}		2.0		μs			1.2		μs	
t_f		1.5		μs			0.7		μs	
f_T		50		MHz	$V_{CE}=12\text{V}, I_E=-1\text{A}$		50		MHz	$V_{CE}=-12\text{V}, I_E=1\text{A}$
C_{ob}		100		pF	$V_{CB}=10\text{V}, f=1\text{MHz}$		180		pF	$V_{CB}=-10\text{V}, f=1\text{MHz}$

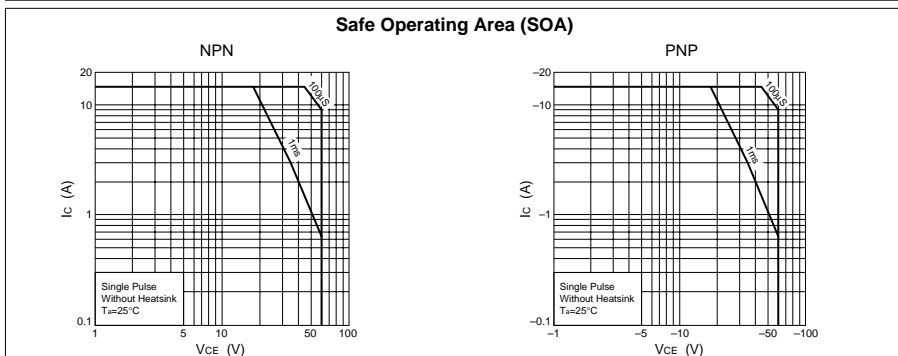
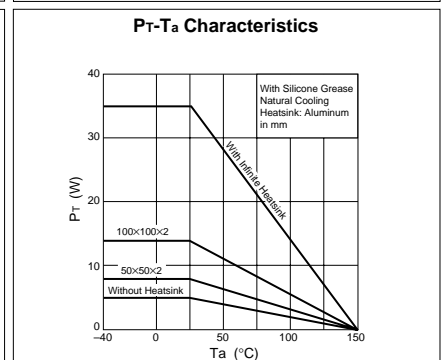
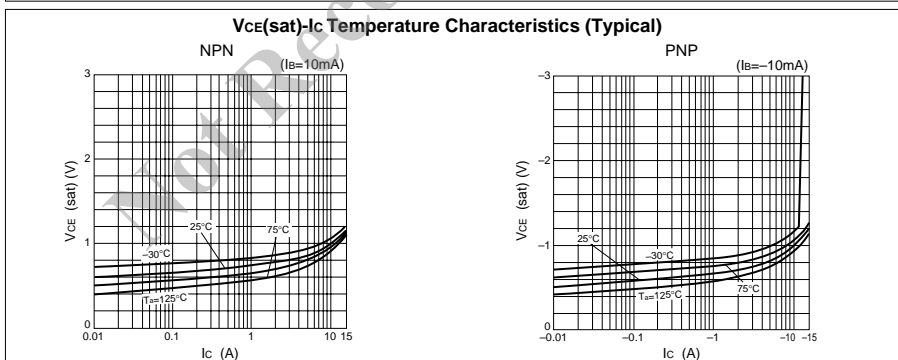
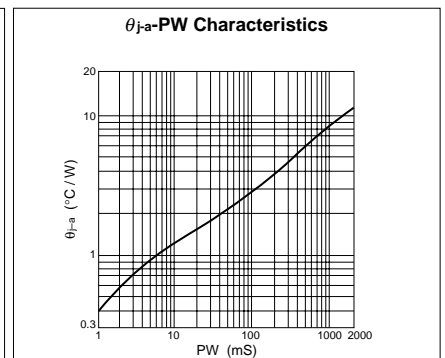
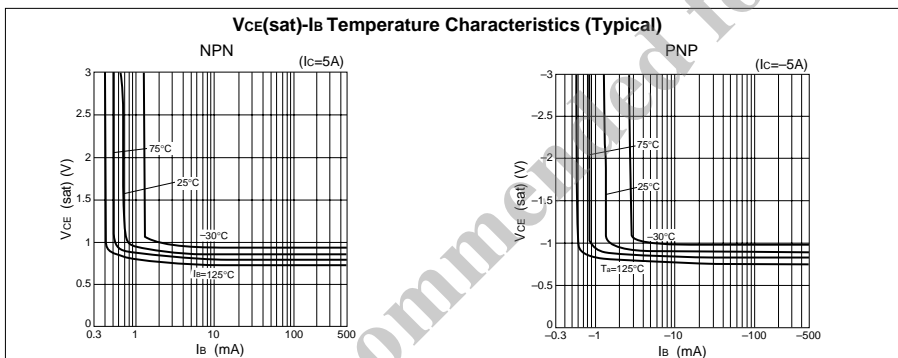

• SIP 8 (STA8Pin)

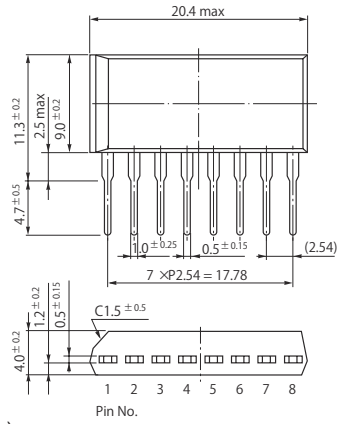

• SIP 10 (STA10Pin)

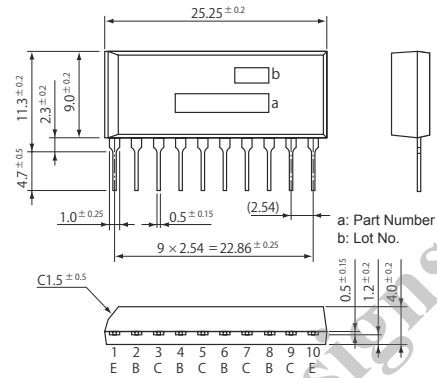

• SIP 12 (SMA12Pin)

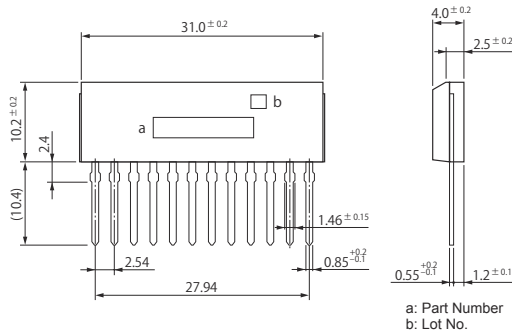

• SIP 15 (SMA15Pin)

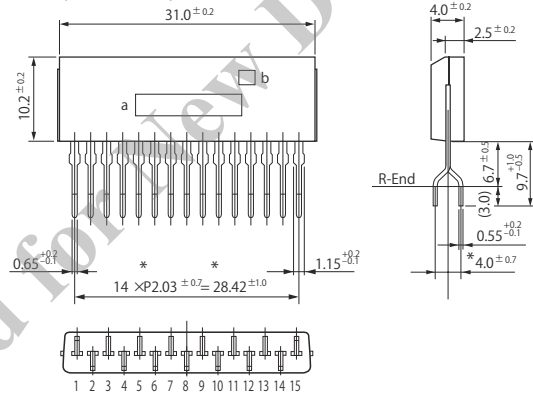

• SIP 12 with Fin (SLA12Pin)

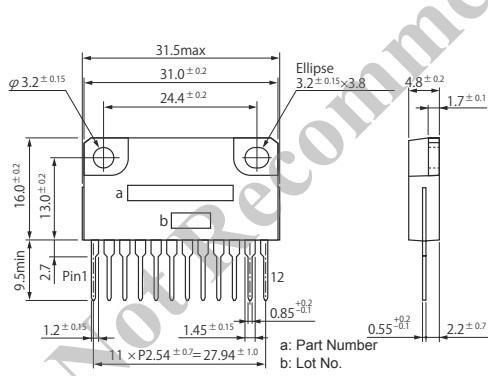

• SIP 15 with Fin (SLA15Pin)

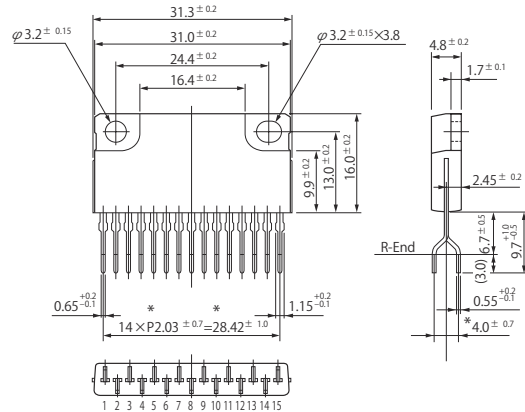

• SIP 21 with Fin (SLA21Pin)

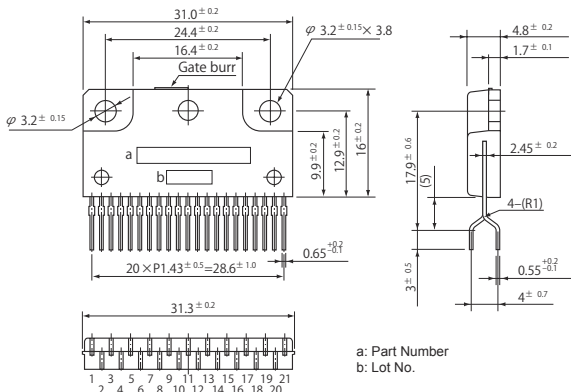

(Unit:mm)