

Top View of Assembly

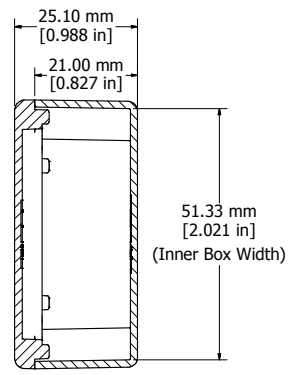

SECTION B-B  
End View of Assembly

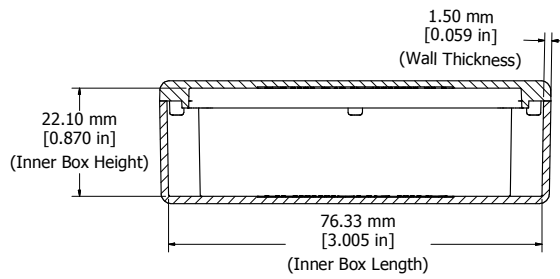

SECTION A-A  
Side View of Assembly

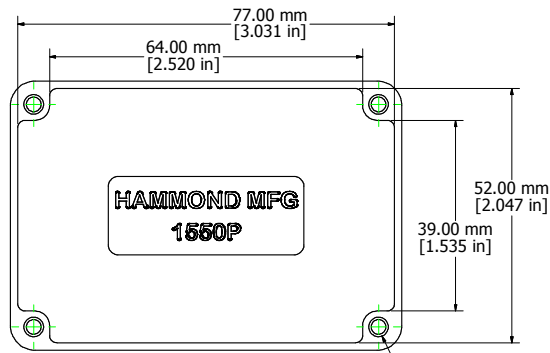

Top View Looking Inside Box

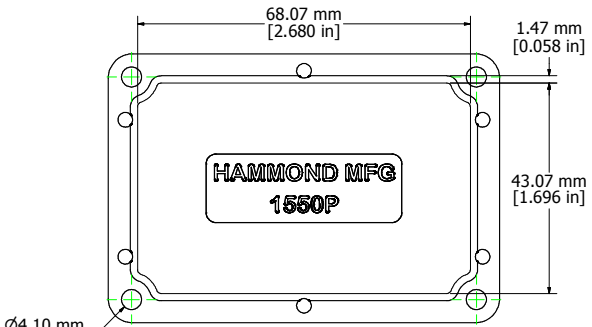

View Looking Inside Lid

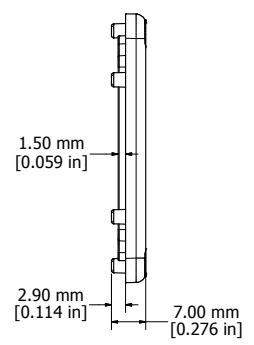

Enclosures can be Factory Modified ( Milling, Drilling, Printing etc. )  
Contact Factory [mjm@hammondmfg.com](mailto:mjm@hammondmfg.com) for quotes  
Solid models of this enclosure available in STEP or IGES.

NOTE	
Purchased assembly includes box, lid, and 4 cover screws.	
Box and lid are made from Diecast Aluminum Alloy.	
EVA Foam Gasket supplied with Liquid Resistant Enclosures	

PART NUMBERS	
1550P Enclosure	
Unfinished	1550P
Black Textured Polyester Powder Paint	1550PBK
1550WP Liquid Resistant Enclosure	
Unfinished	1550WP
Black Textured Polyester Powder Paint	1550WPBK
Accessories	
Recommended Torque: 75 ozf.in / 55 cN.m	
Unfinished Cover Screws (Pkg 100)	1550MS100
[M3.5 x 0.6 18-8 SS]	

