Features

- 32-kHz Voltage Regulated Oscillator
- 1.1 V to 2.2 V Operating-voltage Range
- Integrated Capacitors for Digital Trimming
- Suitable for up to 12.5 pF Quartz
- Trimming Inputs Insensitive to Stray Capacitance
- Output Pulse Formers
- Mask Options for Motor Period and Pulse Width
- Low Resistance Output for Bipolar Stepping Motor
- Motor Fast-test Function

Description

The e1467D is an integrated circuit in CMOS Silicon Gate Technology for analog clocks. It consists of a 32-kHz oscillator, frequency divider, output pulse formers, push-pull motor drivers and alarm output. Integrated capacitors are mask-selectable to accommodate the external quartz crystal. Additional capacitance can be selected through pad bonding to trimming the oscillator frequency.



32-kHz Clock CMOS IC with Digital Trimming and Alarm

e1467D



Pad Configuration

Figure 1. Pad Configuration

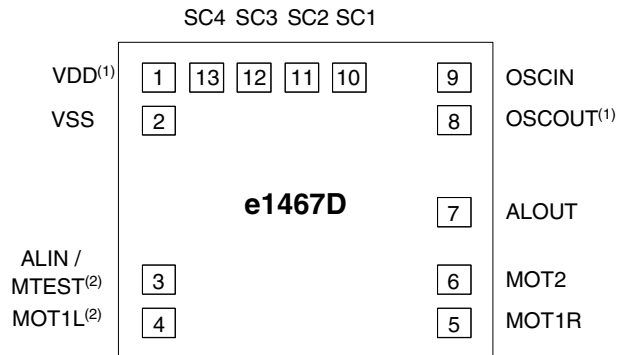

⁽¹⁾ The pads VDD and OSCOUT are interchangeable per mask option

⁽²⁾ The pads for ALIN-/MTEST and MOT1L are interchangeable per mask option

Pin Description

Name	Description
VDD	Positive supply voltage
VSS	Negative supply voltage
OSCIN	Oscillator input
OSCOUT	Oscillator output
MOT1/2	Motor drive outputs
ALIN	Alarm input
ALOUT	Alarm output
SC1 ... SC4	Oscillator trimming inputs

Functional Description

Oscillator

An oscillator inverter with feedback resistor is provided to generate the 32768 Hz clock frequency. Values for the fixed capacitors at OSCIN and OSCOUT are mask-selectable (see note 3 of “Operating Characteristics”). Four control inputs, SC1 to SC4, enable the users to add integrated trimming capacitors to OSCIN and OSCOUT, providing 15 tuning steps.

A frequency variation of typically 4 ppm for each tuning step is obtained by bonding the capacitor pads to OSCIN. As none of these pads are bonded, the IC is in an untrimmed state. Figure 2 shows the trimming curve characteristic.

Note: For applications which utilize this integrated trimming feature, Atmel will determine optimum values for the integrated capacitors C_{OSCIN} and C_{OSCOUT} .

Motor Drive Output

The e1467D contains two push-pull output buffers for driving bipolar stepping motors. During a motor pulse, the N-channel device of one buffer and the P-channel device of the other buffer will be activated. Both N-channel transistors are on and conducting between output pulses. The outputs are protected against inductive voltage spikes with diodes to both supply pins. The motor output period and pulse width are mask-programmable, as listed below:

Available motor periods (T_M): 125, 250, 500 ms and 2, 16 s

Available maximum pulse widths (t_M): 15, 6, 23.4, 31.25, 46.9 ms

Available motor periods for motor test (T_{MT}): 250, 500 ms and 1 s

Note: The following constraints for combination of motor period and pulse widths have to be considered: $T_M > 4 \times t_M$, $T_{MT} > 4 \times t_M$ or alternatively $T_M = 2 \times t_M$, $T_{MT} = 2 \times t_M$

Alarm Outputs

The alarm output driver consists of a push-pull stage for driving a speaker via an external bipolar transistor. The output is configured for NPN and PNP bipolar capability. The output is an alarm tone, modulated by a low frequency. Tone frequencies, modulation frequencies, and on/off times are selectable via the metal mask option.

Alarm Input

A debounced alarm input is provided. Alarm activation is connected either to V_{DD} or V_{SS} by a mask option.

Test Functions

For test purposes, the TEST pad is open. With a high resistance probe ($R \geq 10 \text{ M}\Omega$, $C \geq 20 \text{ pF}$), a test frequency f_{TEST} of 128 Hz can be measured at the ALIN/MTEST pad. Connecting ALIN/MTEST (for at least 32 ms) to the opposite polarity for alarm activation changes the motor period from the selected value to T_{MT} (mask-selectable) while the pulse width remains unaffected. This feature can be used for testing the mechanical parts of the clock.

Figure 2. Functional Test

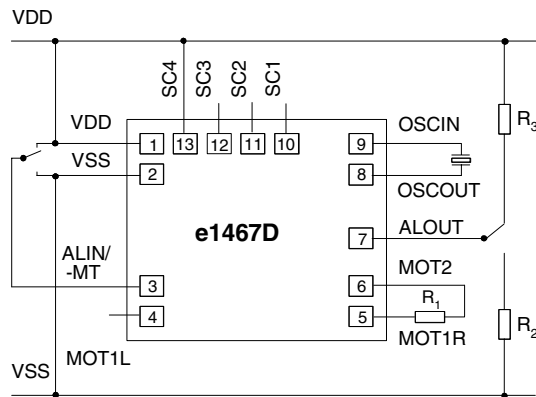

Test Crystal Specification

Oscillation frequency	$f_{OSC} = 32768 \text{ Hz}$
Series resistance	$R_S = 30 \text{ k}\Omega$
Static capacitance	$C_0 = 1.5 \text{ pF}$
Dynamic capacitance	$C_1 = 3.0 \text{ fF}$
Load capacitance	C_L optionally 10 or 12.5 pF

Absolute Maximum Ratings

Absolute maximum ratings define parameter limits which, if exceeded, may permanently change or damage the device. All inputs and outputs on Atmel's circuits are protected against electrostatic discharges. However, precautions to minimize the build-up of electrostatic charges during handling are recommended. The circuit is protected against supply voltage reversal for typically 5 minutes.

Parameters	Symbol	Value	Unit
Supply voltage	V_{SS}	-0.3 to 5 V	V
Input voltage range, all inputs	V_{IN}	$(V_{SS} - 0.3 \text{ V}) \leq V_{IN} \leq (V_{DD} + 0.3 \text{ V})$	V
Output short circuit duration		indefinite	
Power dissipation (DIL package)	P_{tot}	125	mW
Operating ambient temperature range	T_{amb}	-20 to +70	°C
Storage temperature range	T_{stg}	-40 to +125	°C
Lead temperature during soldering at 2 mm distance, 10 s	T_{sld}	260	°C

Operating Characteristics

$V_{SS} = 0\text{ V}$, $V_{DD} = 1.5\text{ V}$, $T_{amb} = +25^\circ\text{C}$, unless otherwise specified.

All voltage levels are measured with reference to V_{SS} . Test crystal as specified below.

Parameters	Test Conditions	Symbol	Min.	Typ.	Max.	Unit
Operating voltage		V_{DD}	1.1	1.5	2.2	V
Operating temperature		T_{amb}	-20		+70	$^\circ\text{C}$
Operating current	$R_1 = \infty$ ⁽²⁾	I_{DD}		1	3	μA
Motor Drive Output						
Motor output current	$V_{DD} = 1.2\text{ V}$, $R_1 = 200\ \Omega$	I_M	± 4.3			mA
Motor period		T_M	See option list			s
Motor period during motor test		T_{MT}	See option list			ms
Motor pulse width		t_M	See option list			ms
Oscillator						
Start-up voltage	Within 2 s	V_{START}	1.2		2.2	V
Frequency stability	$\Delta V_{DD} = 100\text{ mV}$, $V_{DD} = 1.1\text{ to }2.2\text{ V}$	$\Delta f/f$		0.1	0.2	ppm
Integrated input capacitance	⁽³⁾	C_{OSCIN}	See option list			pF
Integrated output capacitance		C_{OSCOU}	See option list			pF
Input current SC1 to SC4	$V_{IN} = 0.2\text{ V}$ $V_{IN} = V_{DD}$ ⁽⁵⁾	I_{SCINL}	1	5	25	μA
		I_{SCINH}	0.05	0.15	0.5	μA
Alarm/Output						
Output current for driving npn transistor	$V_{DD} = 1.2\text{ V}$					
N-channel	$R_3 = 100\text{ k}\Omega$	I_{ANn}	1	3	10	μA
P-channel	$R_2 = 1\text{ k}\Omega$ ⁽²⁾⁽⁴⁾	I_{ANp}	-0.5	-1		mA
Output current for driving pnp-transistor	$V_{DD} = 1.2\text{ V}$					
N-channel	$R_3 = 1\text{ k}\Omega$	I_{APn}	0.5	1		mA
P-channel	$R_2 = 100\text{ k}\Omega$ ⁽²⁾⁽⁴⁾	I_{APp}	-1	-2	-10	μA
Alarm Options						
Tone frequency		f_A	See option list			Hz
Modulation frequency		f_{MOD}	See option list			Hz
On/off time		t_{ON}/t_{OFF}	See option list			s
Alarm Input/Motor Test						
Input current	$ALIN = V_{DD}$, peak current	I_{AINH}	0.6	3	10	μA
Input current	$ALIN = V_{SS}$, peak current	I_{AINL}	-0.6	-3	-10	μA
Input debounce delay		t_{AIN}	23.4		31.2	ms

- Notes:
1. Typical parameters represent the statistical mean values
 2. See test circuit
 3. Values can be selected in 1 pF steps. A total capacitance ($C_{OSCIN} + C_{OSCOU}$) of 38 pF is available
 4. NPN or PNP driving transistors defined by mask options
 5. I_{SCINH} is the peak current of a pulsed current with a duty cycle of 1:63. Average current is always smaller than 10 nA

Figure 3. Motor Output Signal During Normal Operation and During Motor Test

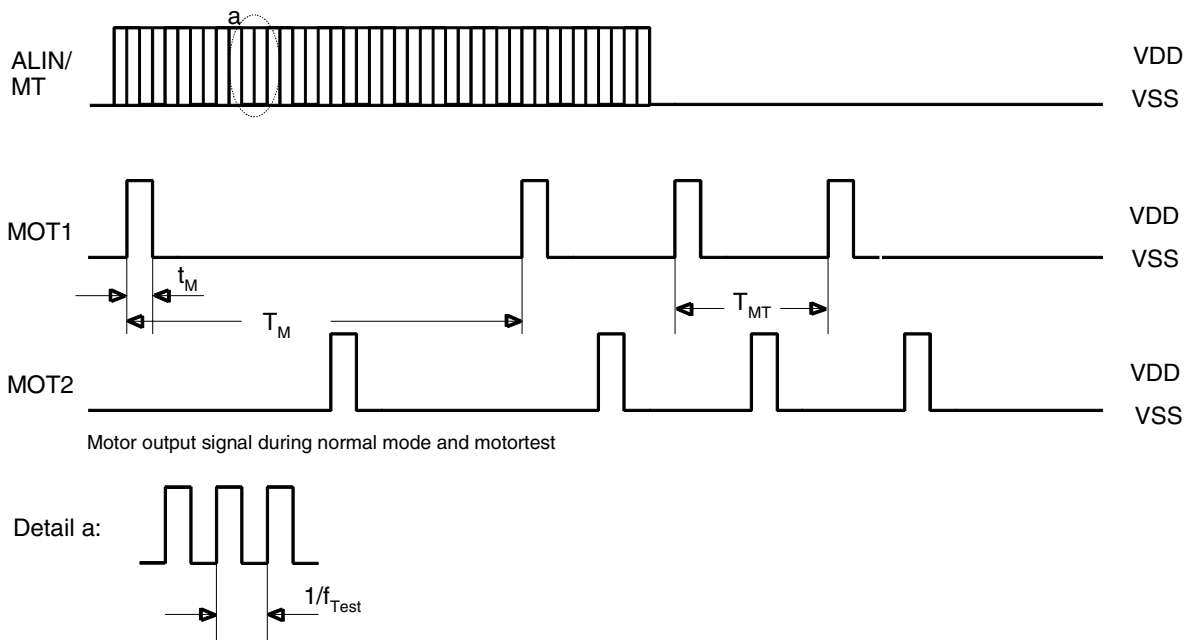

Figure 4. Alarm Operation

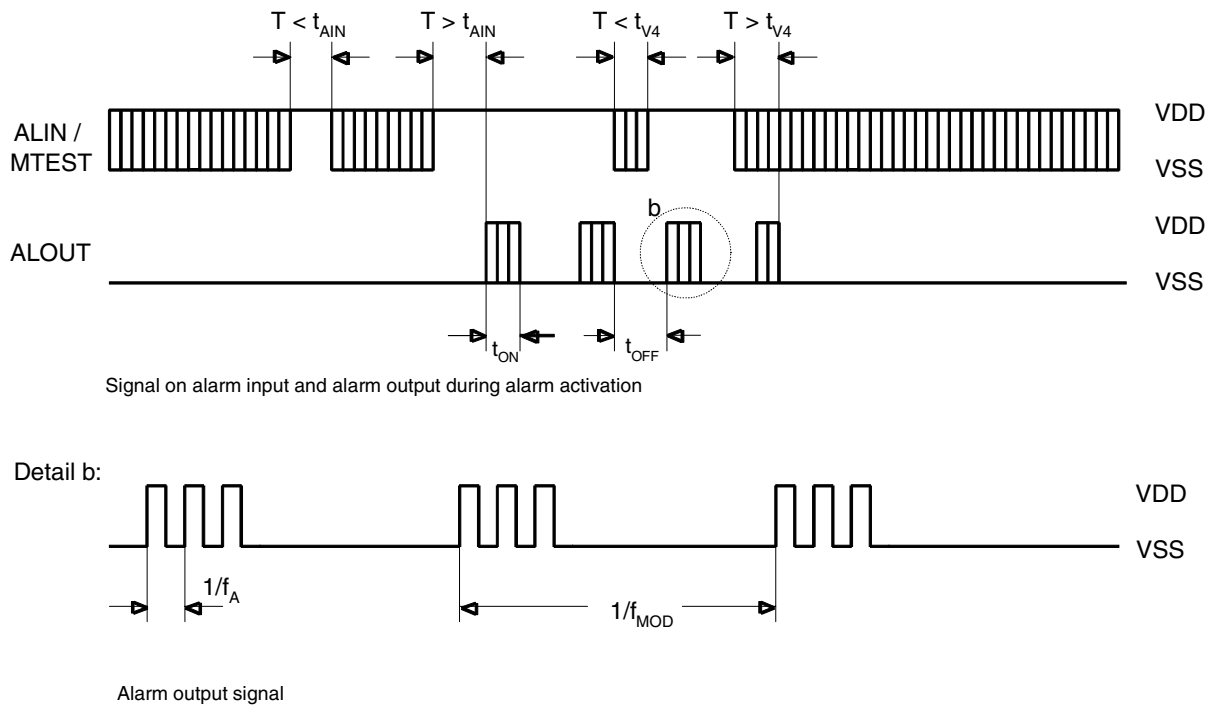
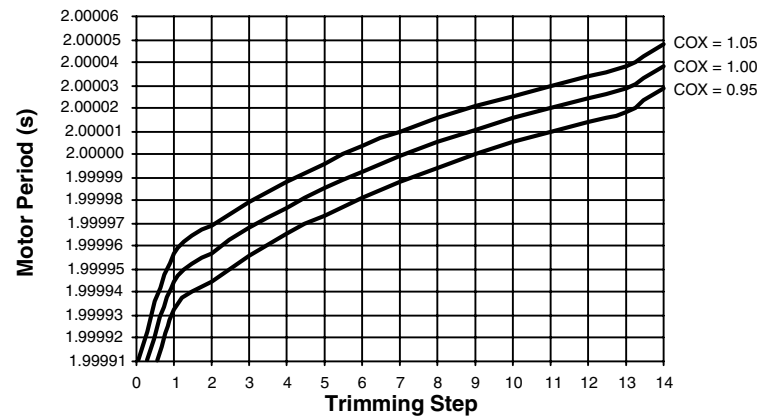

Figure 5. Typical Trimming Curve Characteristic for T_M of 2 s



C_{OX} means frequency deviation due to production process variations.

Trimming inputs SC1 ... SC4 are binary weighted, i.e.,

SC1 ... SC4 = 0 corresponds to trimming step 0

SC1 ... SC4 = 1 corresponds to trimming step 15

LSB = SC1



Ordering Information

Table 1. Option List e1467D

Option	Motor			Alarm					Load Cap. pF	Integrated Capacitance	
	Cycle (T _M) s	Pulse (t _M) ms	Test (T _{MT}) ms	Frequency Hz	Modulation Frequency Hz	On/off Time s	Driver Type	Activation Polarity		C _{OSCIN} ⁽¹⁾ pF	C _{OSCOUT} ⁽¹⁾ pF
-B	2	23.4	250	2048	8	0.5/0.5	NPN	V _{SS}	10	17	12
-D	2	31.25	250	2048	8	0.5/0.5	NPN	V _{DD}	10	17	12
-V2	0.5	23.4	250	2048	8	0.5/0.5	NPN	V _{SS}	12.5	20	16
E2	2	46.9	250	2048	8	1/3	NPN	V _{SS}	12.5	20	16

Note: 1. On-chip stray capacitance included

Option	Pad Designation												
	Pad 1	Pad 2	Pad 3	Pad 4	Pad 5	Pad 6	Pad 7	Pad 8	Pad 9	Pad 10	Pad 11	Pad 12	Pad 13
-B	OSCIN	V _{DD}	ALOUT	MOT2	MOT1	MOT1	ALIN/MTEST	V _{SS}	OSCOUT	SC4	SC3	SC2	SC1
-D	OSCIN	OSCOUT	ALOUT	MOT2	MOT1	MOT1	ALIN/MTEST	V _{SS}	V _{DD}	SC4	SC3	SC2	SC1
-V2	OSCIN	V _{DD}	ALOUT	MOT2	MOT1	MOT1	ALIN/MTEST	V _{SS}	OSCOUT	SC4	SC3	SC2	SC1
-D	OSCIN	OSCOUT	ALOUT	MOT2	MOT1	ALIN/TEST	MOT1	V _{SS}	V _{DD}	SC4	SC3	SC2	SC1



Atmel Corporation

2325 Orchard Parkway
San Jose, CA 95131
Tel: 1(408) 441-0311
Fax: 1(408) 487-2600

Regional Headquarters

Europe

Atmel Sarl
Route des Arsenaux 41
Case Postale 80
CH-1705 Fribourg
Switzerland
Tel: (41) 26-426-5555
Fax: (41) 26-426-5500

Asia

Room 1219
Chinachem Golden Plaza
77 Mody Road Tsimshatsui
East Kowloon
Hong Kong
Tel: (852) 2721-9778
Fax: (852) 2722-1369

Japan

9F, Tonetsu Shinkawa Bldg.
1-24-8 Shinkawa
Chuo-ku, Tokyo 104-0033
Japan
Tel: (81) 3-3523-3551
Fax: (81) 3-3523-7581

Atmel Operations

Memory

2325 Orchard Parkway
San Jose, CA 95131
Tel: 1(408) 441-0311
Fax: 1(408) 436-4314

Microcontrollers

2325 Orchard Parkway
San Jose, CA 95131
Tel: 1(408) 441-0311
Fax: 1(408) 436-4314

La Chantrerie
BP 70602
44306 Nantes Cedex 3, France
Tel: (33) 2-40-18-18-18
Fax: (33) 2-40-18-19-60

ASIC/ASSP/Smart Cards

Zone Industrielle
13106 Rousset Cedex, France
Tel: (33) 4-42-53-60-00
Fax: (33) 4-42-53-60-01

1150 East Cheyenne Mtn. Blvd.
Colorado Springs, CO 80906
Tel: 1(719) 576-3300
Fax: 1(719) 540-1759

Scottish Enterprise Technology Park
Maxwell Building
East Kilbride G75 0QR, Scotland
Tel: (44) 1355-803-000
Fax: (44) 1355-242-743

RF/Automotive

Theresienstrasse 2
Postfach 3535
74025 Heilbronn, Germany
Tel: (49) 71-31-67-0
Fax: (49) 71-31-67-2340

1150 East Cheyenne Mtn. Blvd.
Colorado Springs, CO 80906
Tel: 1(719) 576-3300
Fax: 1(719) 540-1759

Biometrics/Imaging/Hi-Rel MPU/ High Speed Converters/RF Datacom

Avenue de Rochepleine
BP 123
38521 Saint-Egreve Cedex, France
Tel: (33) 4-76-58-30-00
Fax: (33) 4-76-58-34-80

e-mail

literature@atmel.com

Web Site

<http://www.atmel.com>

Disclaimer: Atmel Corporation makes no warranty for the use of its products, other than those expressly contained in the Company's standard warranty which is detailed in Atmel's Terms and Conditions located on the Company's web site. The Company assumes no responsibility for any errors which may appear in this document, reserves the right to change devices or specifications detailed herein at any time without notice, and does not make any commitment to update the information contained herein. No licenses to patents or other intellectual property of Atmel are granted by the Company in connection with the sale of Atmel products, expressly or by implication. Atmel's products are not authorized for use as critical components in life support devices or systems.

© Atmel Corporation 2003. All rights reserved.

Atmel® and combinations thereof are the registered trademarks of Atmel Corporation or its subsidiaries.

Other terms and product names may be the trademarks of others.



Printed on recycled paper.