

THIS DRAWING IS UNPUBLISHED. RELEASED FOR PUBLICATION. COPYRIGHT BY TYCO ELECTRONICS CORPORATION. ALL RIGHTS RESERVED.

PART NUMBER	REV	FIRST USED
567456-1	E	122500-1
567456-2	E	565435-5
567456-3	D	354500-1

OBSOLETE

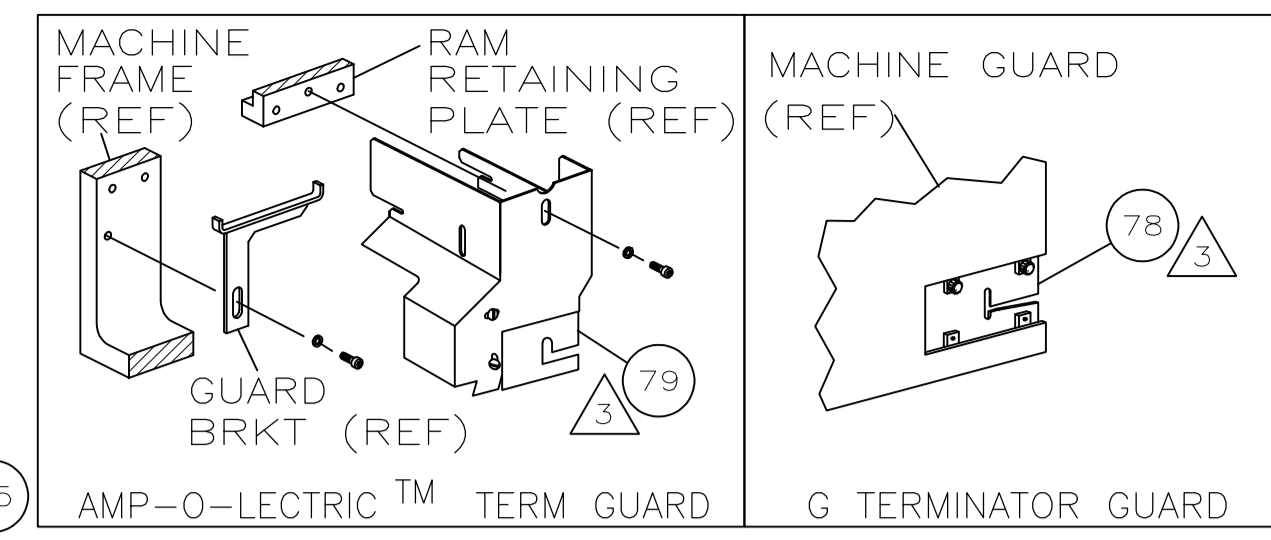

TERMINAL NAME: RECEPTACLE, TWIST LOCK

FEED	CRIMP DATA (AMP TERMINAL)
.760 FEED	
.810 FEED	
	PAD LTR
	CRIMP HEIGHT
	WIRE SIZE
	A .076 ±.002 [1.93 ±0.05mm] 16
	B .070 ±.002 [1.78 ±0.05mm] 18
	C .067 ±.002 [1.70 ±0.05mm] 20
	D NOT USED
	CRIMP SIZE TYPE RANGE
	WIRE .120 [3.05mm] F 20-16
	INSUL - -
WIRE STRIP LENGTH	TERM APPL SPEC FEED APPL INSTRUCTION SET UP GAGE LAYOUT
.172-.203	NONE .760 .810 408-8040 458637-1 SIM 1035

LOC	DIST	REVISIONS			
F	LTR	DESCRIPTION	DATE	DN	APVD
A	66	E	ECR-08-001499	1-2008	MY GB

-1	LEADMAKER	AIRFEED
-2	BENCH MODEL K	AIRFEED
-3	BENCH MODEL G	AIRFEED

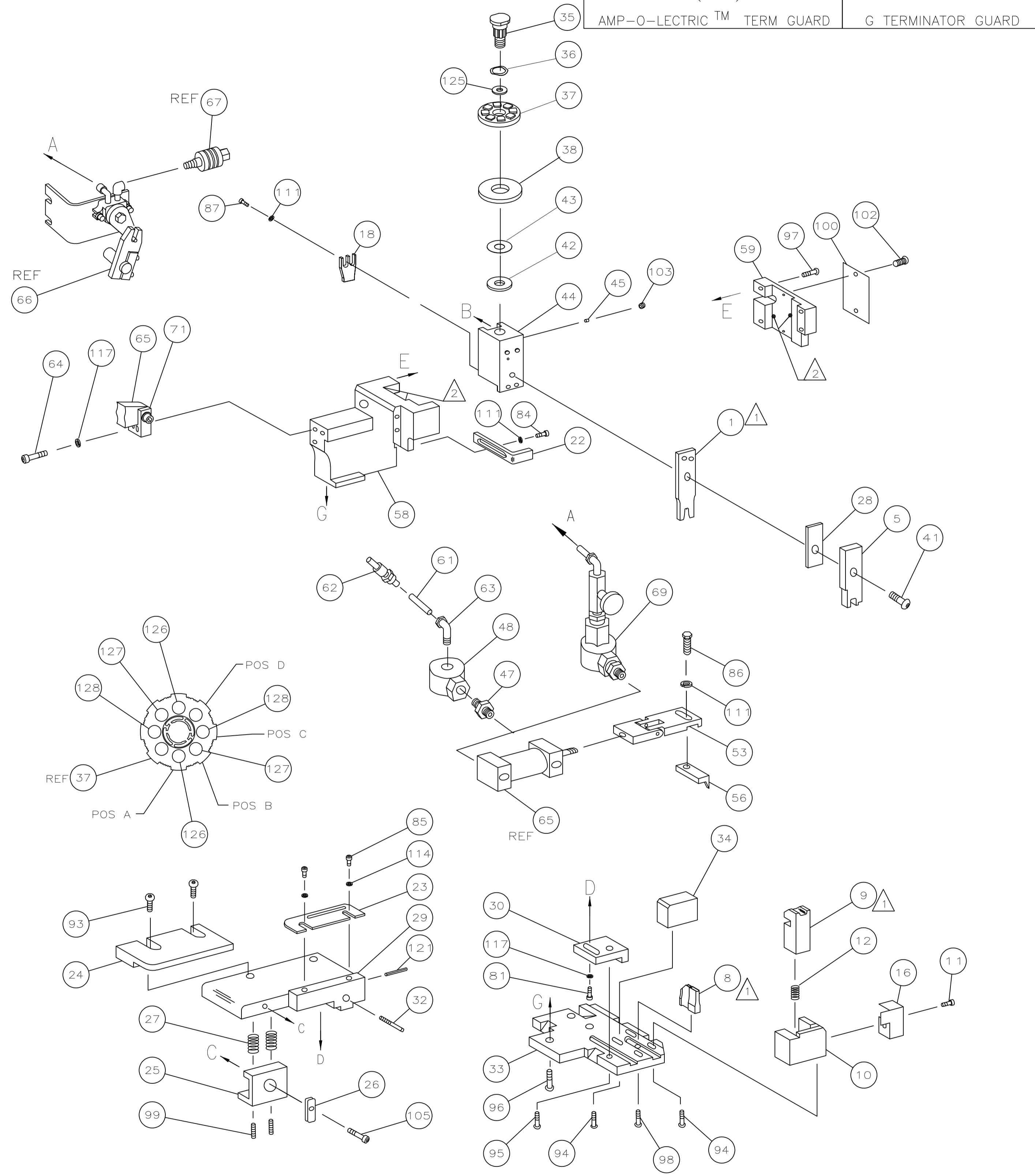

QTY REQD PER ASSY	PART NO	DESCRIPTION	ITEM NO		
2	2	2	9-354778-7	PIN, WIRE DISC (.2980)C	128
2	2	2	9-354778-1	PIN, WIRE DISC (.2950)B	127
2	2	2	7-354778-7	PIN, WIRE DISC (.2880)A	126
1	1	1	986950-1	WASHER, FLAT PRECISION	125
1	1	1	217238-1	GENERAL INSTRUCTION PACKAGE	124
1	1	1	4088040	SF APPL INST 408-8040	123
1	1	1	4-21028-0	PIN,SLT SPR(Ø.093x.75)ST GDE PL	122
3	3	3	21024-5	WASHER, LOCK(#10)ADJ BLOCK	117
2	2	2	21024-2	WASHER,LOCK(#4)FRONT STP GUIDE	114
4	4	4	21024-4	WASHER,LOCK(#8)STRIPPER	111
1	1	1	22353-8	SCR,SHLD(Ø.187x.25)DRAG LEVER	105
1	1	1	21009-2	SCR,SKT SET(1/4-20x.25 LW)RAM	103
2	2	2	21017-2	SCR,DRIVE(#2x.19)ID PLATE	102
1	1	1	461264-1	PLATE, IDENTIFICATION	100
2	2	2	5-21006-6	SCR,SET(10-32x.75)DRAG	99
1	1	1	22733-8	SCR,BHC(8-32x.38 LW)ANVIL	98
4	4	4	2-21002-9	SCR,BHC(10-32x.75)CAP	97
3	3	3	2-22733-8	SCR,BHC(1/4-20x.62)HSG	96
1	1	1	2-21002-7	SCR,BHC(10-32x.50)SG ADJ BLK	95
4	4	4	2-21002-2	SCR,BHC(8-32x.50)TERM H DWN	94
2	2	2	2-21002-3	SCR,BHC(8-32x.62)R STP GDE	93
2	2	2	7-21000-6	SCR,SHC(8-32x.312)DEP-HOLD	87
1	1	1	2-22603-1	SCR,HEX HD(8-32x.38)FEED FINGER	86
2	2	2	1-21000-3	SCR,SHC(4-40x.25)F ST GUIDE	85
1	1	1	2-21000-7	SCR,SHC(8-32x.50)STRIPPER	84
1	1	1	3-21000-4	SCR,SHC(10-32x.38)SG ADJ BL	81
REF	-	-	462992-7	GUARD ASSY	79
REF	-	-	679532-1	INSERT, GUARD	78
1	1	1	459610-3	MOUNT, FEED BRACKET	71

QTY REQD PER ASSY	PART NO	DESCRIPTION	ITEM NO		
1	1	1	692655-5	AIR FEED VALVE ASSY	70
REF	-	-	24042-2	VALVE, SHUT OFF	68
REF	-	-	692655-6	AIR FEED VALVE ASSY	67
1	1	1	461065-1	AIR FEED ASSY (1 INCH)	66
2	2	2	3-21000-9	SCR,SHC(10-32x.75)AIR ASSY	64
1	1	1	980285-2	ELBOW, SWIVEL 1/8 NPT - 1/4 T	63
1	1	1	23238-1	QUICK DISCONNECT	62
21	00	-	21.00	TUBING, POLY-FLO Ø.25	61
1	1	1	454220-1	CAP, RAM	60
1	1	1	454485-1	HOUSING	59
1	1	1	1-694433-7	PAWL, FEED	58
1	1	1	461062-1	FEED FINGER ASSY	57
1	1	1	22374-7	VALVE, QUICK EXHAUST	56
1	1	1	22304-1	NIPPLE, HEX 1/8 NPT	55
1	1	1	690191-1	PLUG, NYLON	54
1	1	1	455673-1	RAM	53
1	1	1	690125-1	WASHER, LAMINATED	52
1	1	1	690124-9	WASHER, RAM	51
1	1	1	7-21002-9	BOLT, CRIMPER(5/16x1.00)	50
1	1	1	690223-2	SPACER, INSULATION DISC	49
1	1	1	354777-1	WIRE DISC, PLASTIC	48
1	1	1	22480-5	WASHER, SPRING	47
1	1	1	690212-1	POST, RAM	46
1	1	1	690786-3	SUPPORT, TERMINAL	45
1	1	1	455675-1	PLATE, BASE	44
1	1	1	690432-3	SCREW, ADJUSTMENT	43
1	1	1	455689-1	BLOCK, STRIP GUIDE ADJ	42
1	1	1	1-458144-3	PLATE, STRIP GUIDE	41
1	1	1	1-455888-7	SPACER, FRONT SHEAR DEP	40
2	2	2	1-22284-0	SPRING, DRAG	39
1	1	1	240793-1	LEVER, DRAG RELEASE	38
1	1	1	240792-1	DRAG, TERMINAL	37
1	1	1	5-690440-7	GUIDE, STRIP (REAR)	36
1	1	1	690438-1	GUIDE, STRIP (FRONT)	35
1	1	1	690472-2	STRIPPER	34
1	1	1	1-690518-7	HOLDER, TERMINAL	33
1	1	1	318563-1	GUARD, CHIP, FRONT	32
1	1	1	3-22280-3	SPRING, SHEAR	31
1	1	1	690461-1	STOP, SHEAR	30
1	1	1	690459-1	HOLDER, SHEAR (FRONT)	29
1	1	1	454276-1	SHEAR, FLOAT (FRONT)	28
1	1	1	9-690512-8	ANVIL	27
1	1	1	1-455889-4	DEPRESSOR, SHEAR (FRONT)	26
1	1	1	456409-3	CRIMPER, WIRE	25

- 1 RECOMMENDED SPARE PARTS.
- 2 GREASE LIGHTLY.
- 3 GUARD MUST BE IN PLACE WHEN OPERATING APPLICATOR IN A BENCH MACHINE.
- 4 SEE DRAWING FOR COMPONENTS
- 5 CUT TO LENGTH AT ASSY
- 6 REAR STRIP GUIDE & FEED STROKE ADJUSTMENT REQUIRED WHEN SWITCHING TERMINALS.

THIS DRAWING IS A CONTROLLED DOCUMENT.

DIMENSIONS: INCHES	TOLERANCES UNLESS OTHERWISE SPECIFIED:	0 PLC ± .005	1 PLC ± .003	2 PLC ± .002	3 PLC ± .001	4 PLC ± .0005	ANGLES ± .05
MATERIAL	FINISH	WEIGHT	SIZE	CAGE CODE	DRAWING NO	RESTRICTED TO	
			A1	00779	567456		

CUSTOMER DRAWING SCALE - SHEET 1 OF 1 REV E