

MATERIALS AND FINISHES:

BODY BRASS,
73251-4430,-4431,-4432
FINISH GOLD (10 μ-IN MIN) OVER NICKEL (100 μ-IN MIN)
OVER COPPER (50 μ-IN MIN)
73251-4433
FINISH GOLD (1 μ-IN MIN) OVER NICKEL (100 μ-IN MIN)
OVER COPPER (50 μ-IN MIN)

CONTACT BERYLLIUM COPPER
73251-4430,-4431,-4432
FINISH GOLD (10 μ-IN MIN) OVER NICKEL (50 μ-IN MIN)
OVER COPPER (50 μ-IN MIN)
73251-4433
FINISH GOLD (5 μ-IN MIN) OVER NICKEL (100 μ-IN MIN)
OVER COPPER (50 μ-IN MIN)

INSULATOR TEFLON

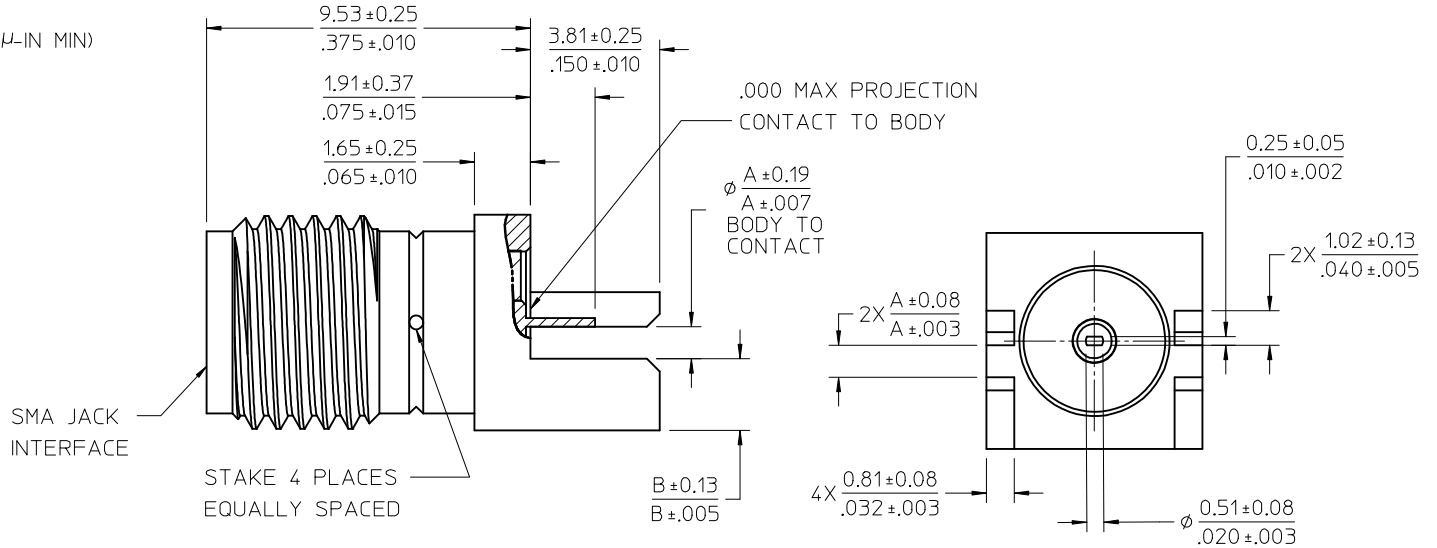
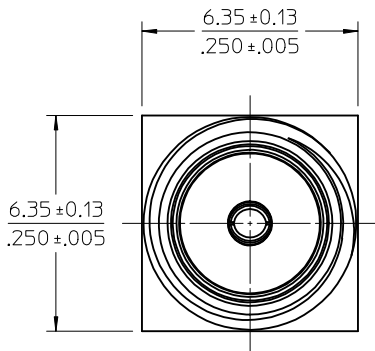

CONTACT RETENTION:
AXIAL 26.7 N(6 LB) MIN
TORQUE 2.82 N-cm(4 IN-OZ) MIN

UL File Number E107635

73251-4433	.048	1.22	.072	1.83
73251-4432	.068	1.73	.052	1.32
73251-4431	.048	1.22	.072	1.83
73251-4430	.037	0.94	.083	2.11
PART NO.	IN	MM	IN	MM
	DIM A		DIM B	

PS-89675-3460	INTERFACE
SPECIFICATION	DESCRIPTION

CHGADD NEW P/N 73251-4433 PDR17022390 EC NO: URF2017-0306 2017/02/14 DRWN:YCHENG CHKD: APPR:YCHENG 2017/02/27 A1	QUALITY SYMBOLS ▽=0 ▽=0	GENERAL TOLERANCES (UNLESS SPECIFIED) mm INCH 4 PLACES ± --- ± --- 3 PLACES ± --- ± --- 2 PLACES ± --- ± --- 1 PLACE ± --- ± --- ANGULAR ± 2°	DIMENSION STYLE MM/IN	SCALE DESIGN UNITS METRIC	THIRD ANGLE PROJECTION	DRAWN BY JLEE02	DATE 2011/03/07	TITLE SMA JACK, PCB END LAUNCH TAB CONTACT, EWR-4636 SMA-J/PCB
						CHECKED BY SSS	DATE 2011/03/07	
DRAFT WHERE APPLICABLE MUST REMAIN WITHIN DIMENSIONS			APPROVED BY JWIENER	DATE 2011/04/11	MOLEX INCORPORATED		DOCUMENT NO. SD-73251-443	SHEET NO. 1 OF 1
THIS DRAWING CONTAINS INFORMATION THAT IS PROPRIETARY TO MOLEX INCORPORATED AND SHOULD NOT BE USED WITHOUT WRITTEN PERMISSION								