







LOC		DIST		REVISIONS			
P	LTN	DESCRIPTION	DATE	DMN	APVD		
D		REVISED PER ECO-12-017092	27SEP2012	KH	DO		

- MATERIAL: COPPER ALLOY
-  SILVER PLATE .000200 MIN THK. OVER NICKEL PLATE .000050 MIN THK. TARNISH RESISTANT COATING OVER ALL
-  GOLD PLATE .000030 MIN THK. OVER NICKEL PLATE .000050 MINIMUM THK.
- PART NUMBER CHANGES AND OR DESIGN CHANGES AFFECTING ITEM INTERCHANGEABILITY REQUIRE TYCO ELECTRONICS APPROVAL AND AUTHORIZATION BY REVISION TO THIS DRAWING.

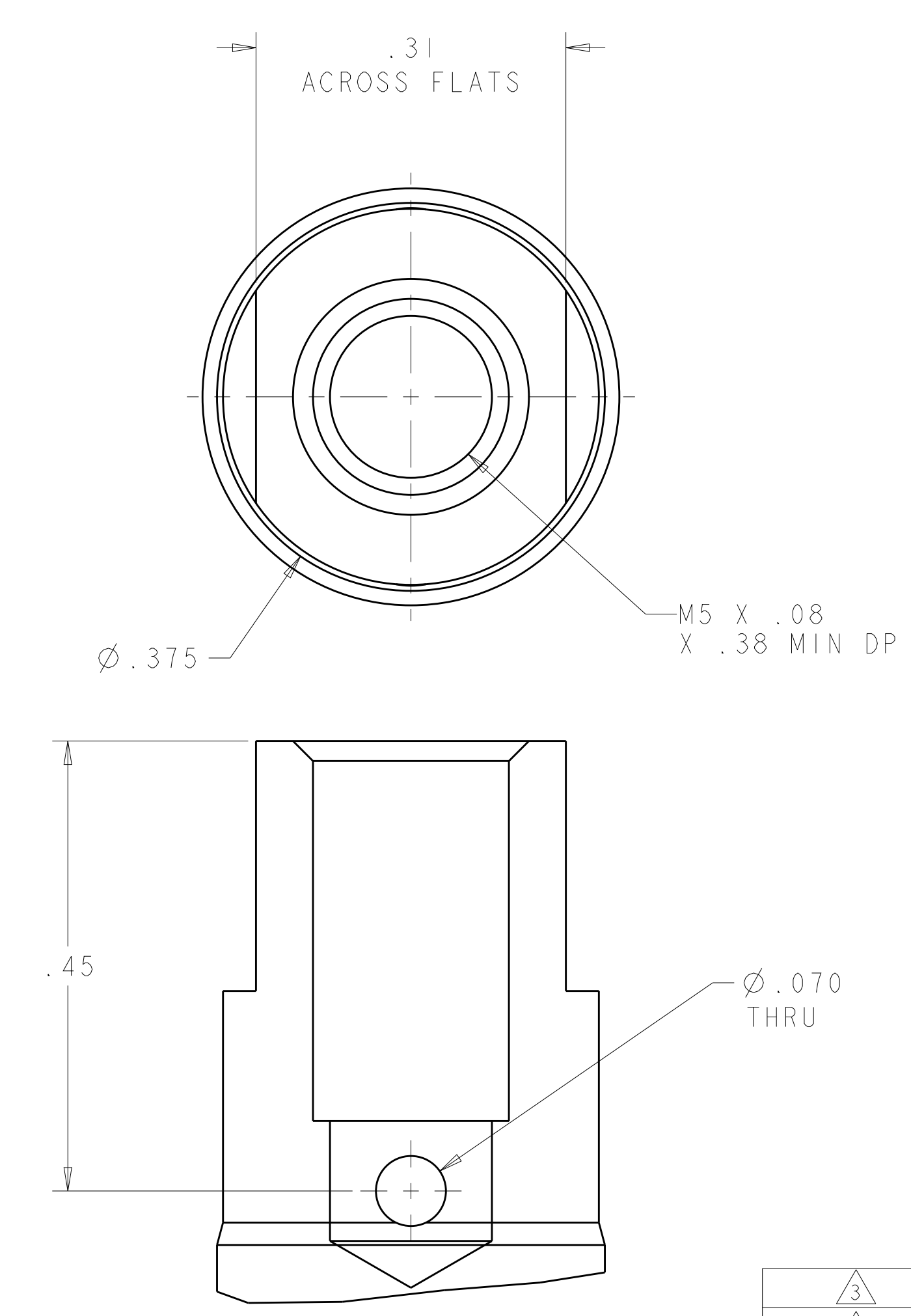
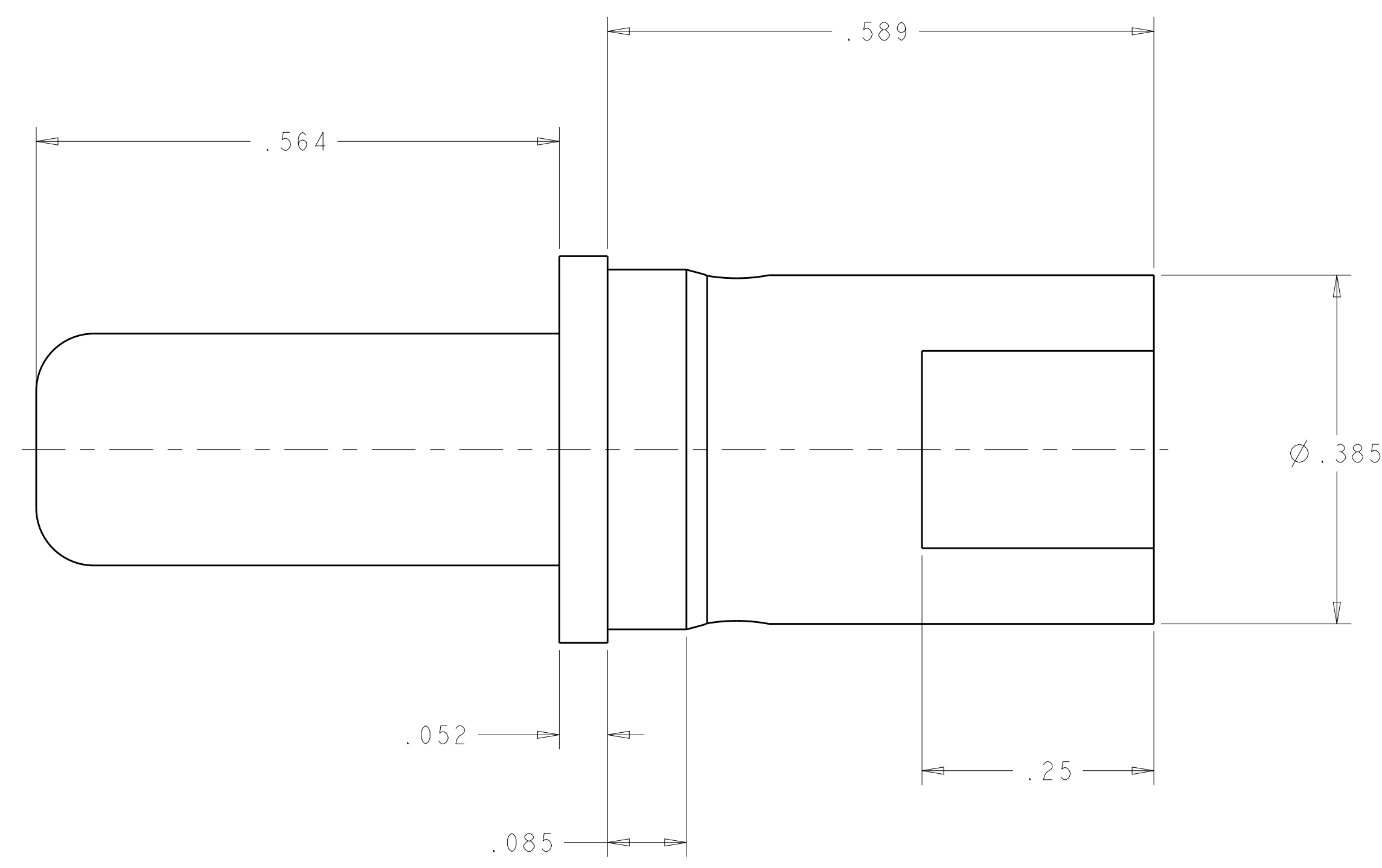
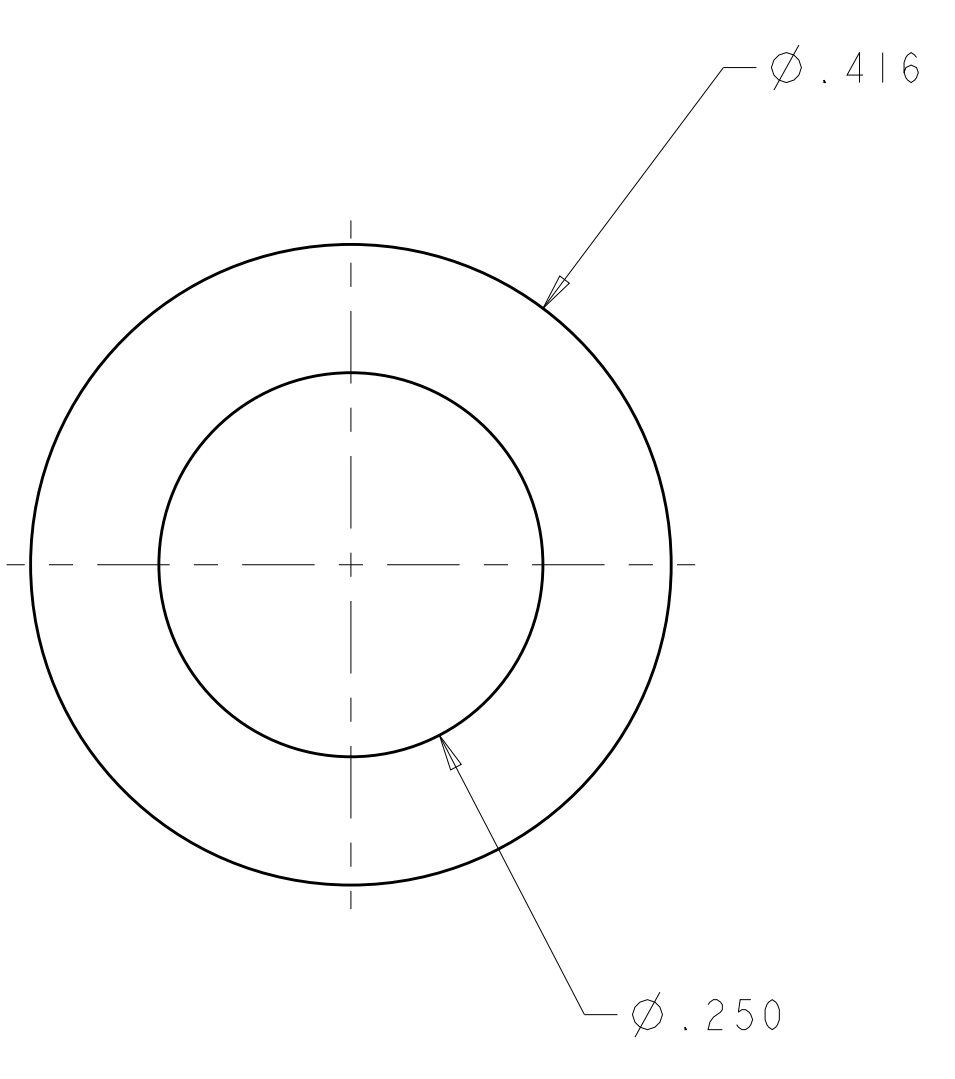

	1766283-2
	1766283-1
FINISH	PART NO

THIS DRAWING IS A CONTROLLED DOCUMENT.		DMN: HM VAN SCOY 26MAR2008	TE Connectivity	
DIMENSIONS: INCHES		CHK: D. DEFIBAUGH 26MAR2008		
TOLERANCES UNLESS OTHERWISE SPECIFIED:		APVD: D. DEFIBAUGH 26MAR2008		
0 PLC ± .01	1 PLC ± .01	PRODUCT SPEC	CONTACT, PIN, .250 DIA, M5 X .08 INT. THD. TAPPED DRAWER, DOMINO	
2 PLC ± .003	3 PLC ± .003	APPLICATION SPEC	SIZE: A100779 C=1766283	
4 PLC ± .003	ANGLES ± .5°	FINISH	RESTRICTED TO	
MATERIAL	FINISH	WEIGHT	SCALE 4:1 SHEET 1 OF 1 REV D	
CUSTOMER DRAWING				