

REVISIONS					
P	LTR	DESCRIPTION	DATE	DWN	APVD
N		REVISED PER ECO-20-013571	17FEB2021	SR	JB

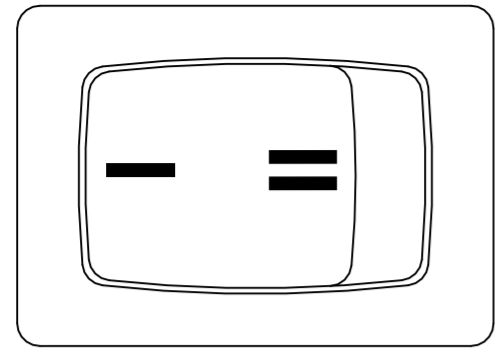

PANEL CUT OUT

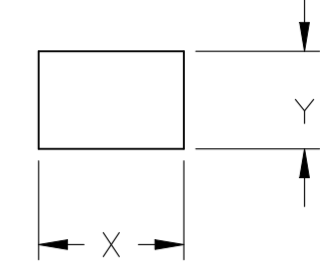

2.00-3.00	19.8-0.1	13.0+0.1
1.25-2.00	19.4-0.1	13.0+0.1
0.75-1.25	19.2-0.1	13.0+0.1
PANEL THICKNESS	X	Y

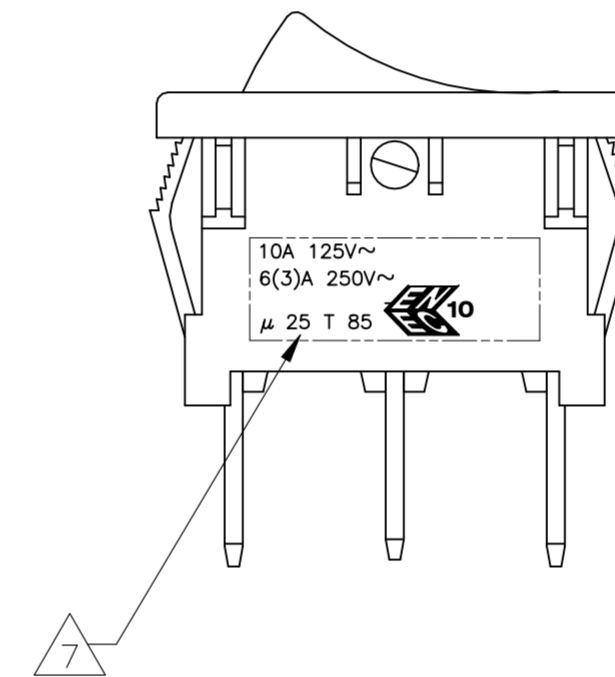
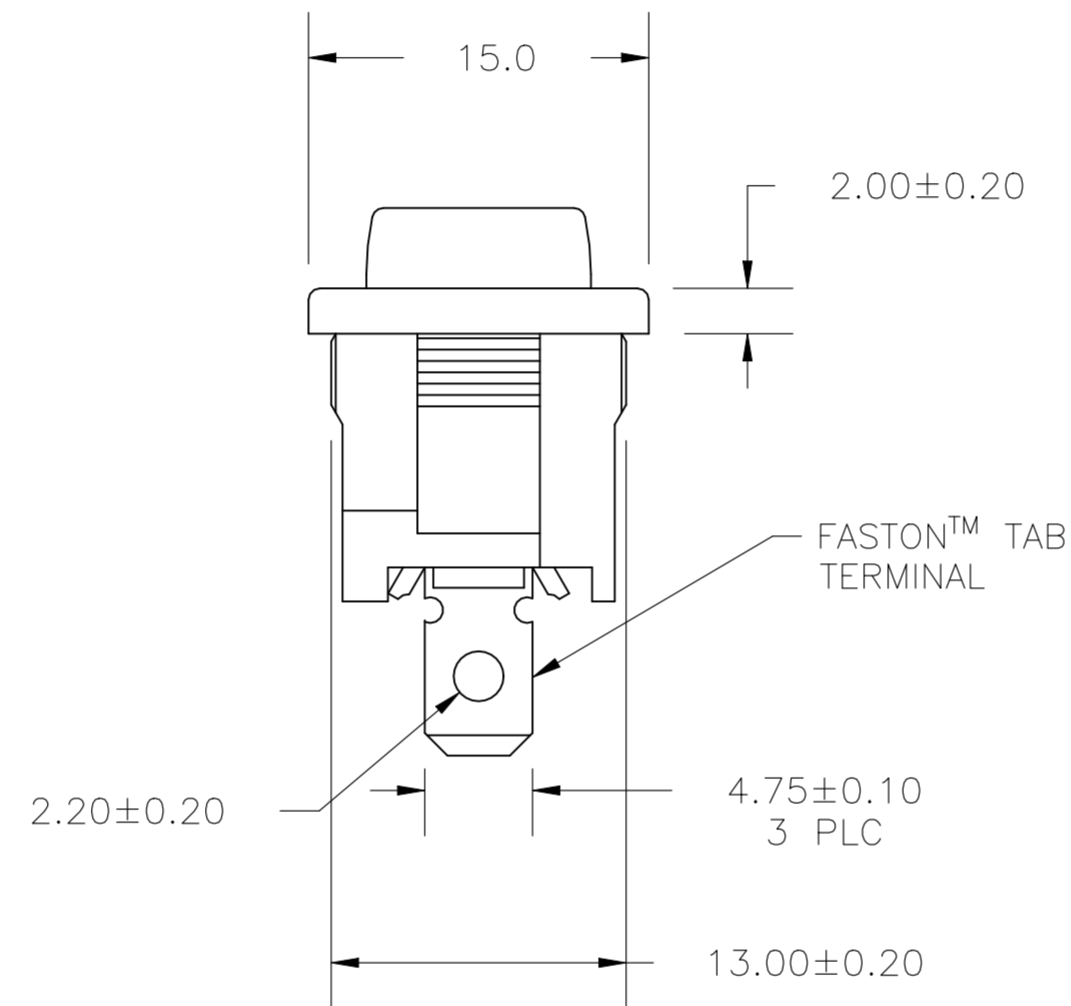
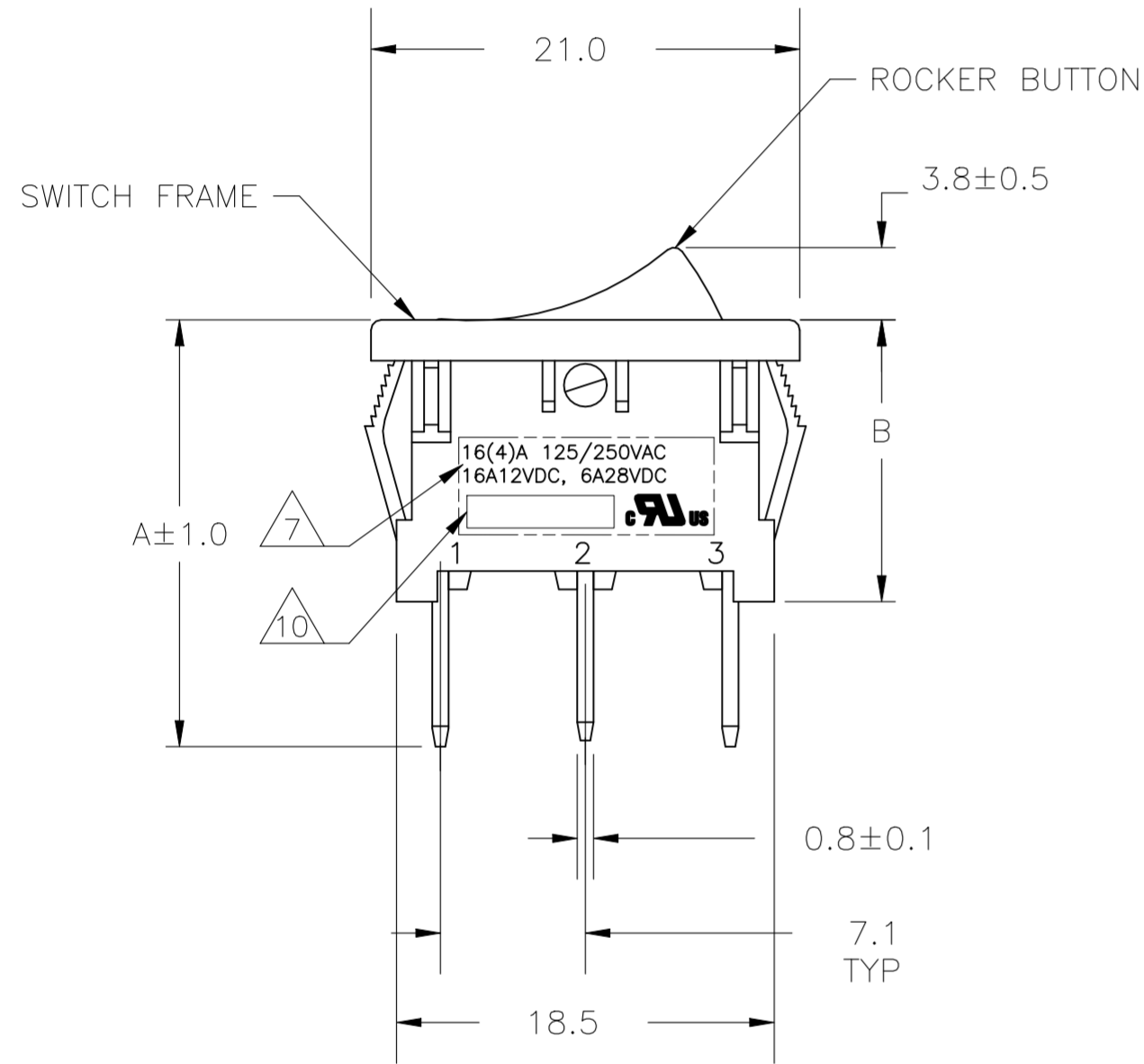

SWITCH FUNCTION D1
CIRCUIT DIAGRAM

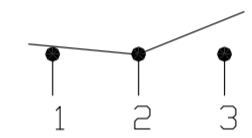

SWITCH FUNCTION D2
CIRCUIT DIAGRAM

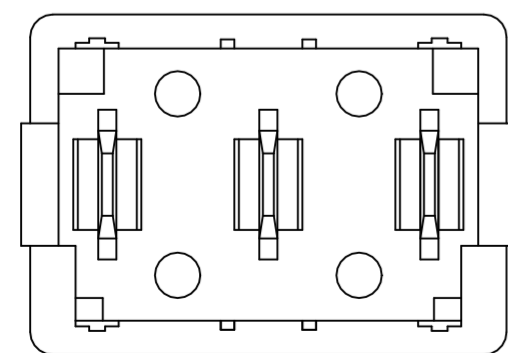
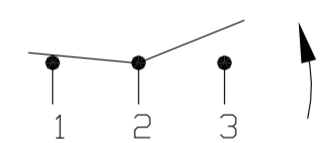

OBSOLETE — 1571079-5 — SHOWN
(TWO ROCKER BUTTON POSITIONS)

THIS DRAWING IS A CONTROLLED DOCUMENT.		DWN M.BINNER	25FEB2002	TE Connectivity Ltd.	
DIMENSIONS: mm		CHK J.MOSIER	APVD -		
TOLERANCES UNLESS OTHERWISE SPECIFIED:		PRODUCT SPEC NOT APPLICABLE		SIZE A2	CAGE CODE 00779
0 PLC ± - 1 PLC ± 0.30 2 PLC ± 0.05 3 PLC ± - 4 PLC ± - ANGLES ± -		APPLICATION SPEC NOT APPLICABLE		DRAWING NO C=1571079	RESTRICTED TO -
MATERIAL 1	FINISH 2	WEIGHT 0	CUSTOMER DRAWING	SCALE 3:1	SHEET 1 of 3
				REV N	

REVISIONS					
P	LTR	DESCRIPTION	DATE	DWN	APVD
-	-	SEE SHEET 1	-	-	-

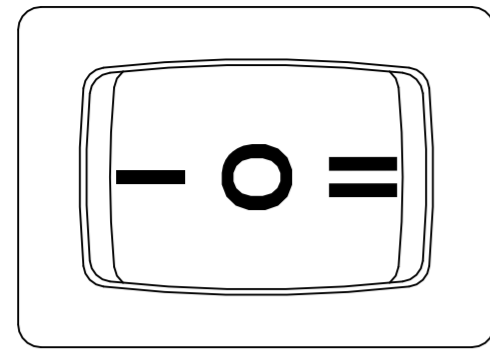

PANEL CUT OUT

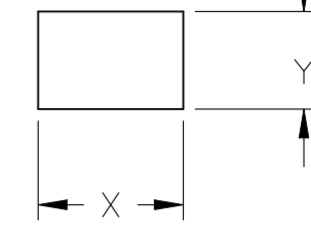

2.00-3.00	19.8-0.1	13.0+0.1
1.25-2.00	19.4-0.1	13.0+0.1
0.75-1.25	19.2-0.1	13.0+0.1
PANEL THICKNESS	X	Y

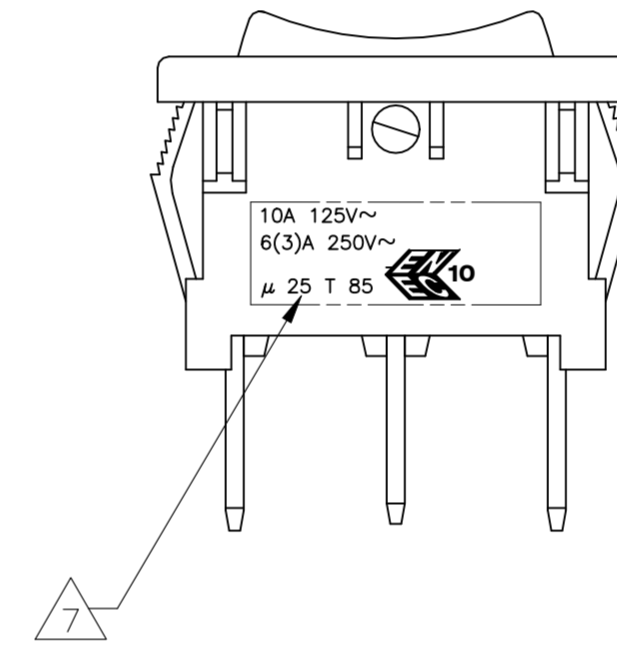
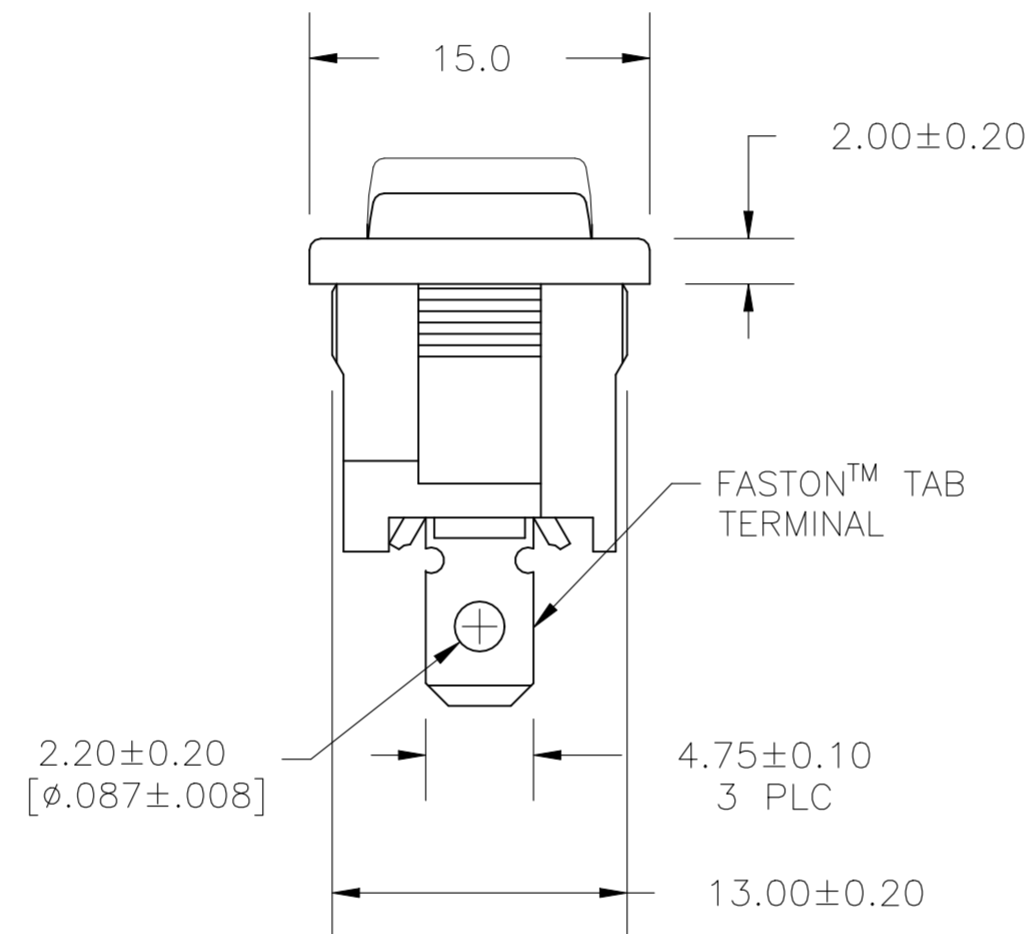
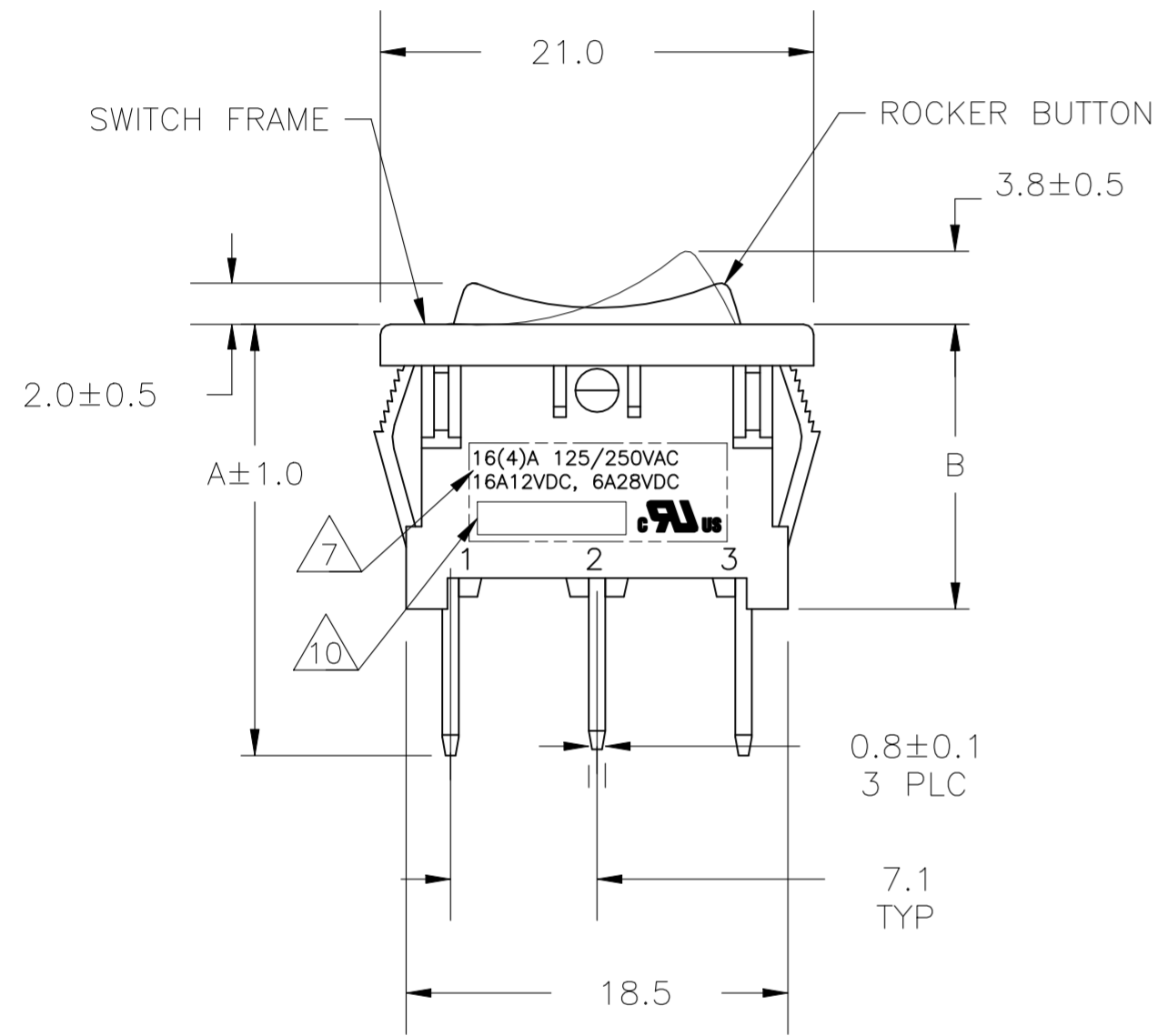

SWITCH FUNCTION D3
CIRCUIT DIAGRAM

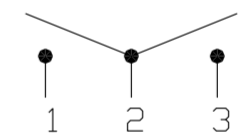

SWITCH FUNCTION D4
CIRCUIT DIAGRAM

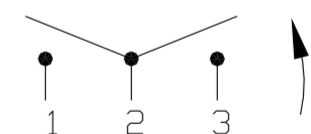

SWITCH FUNCTION D5
CIRCUIT DIAGRAM

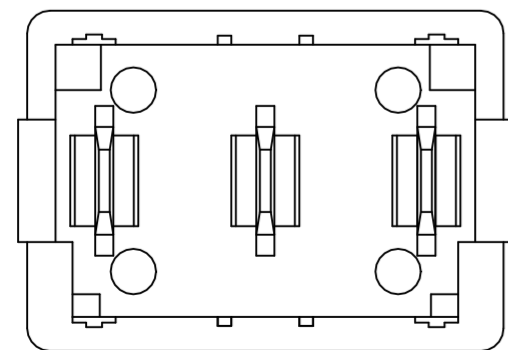
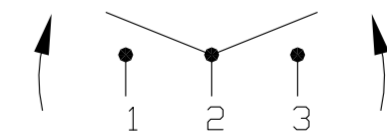

1-1571079-4 SHOWN
(THREE ROCKER BUTTON POSITIONS)

THIS DRAWING IS A CONTROLLED DOCUMENT.		DWN M.BINNER	25FEB2002	TE Connectivity Ltd.	
DIMENSIONS: mm		CHK J.MOSIER	-		
TOLERANCES UNLESS OTHERWISE SPECIFIED:		APVD -	-	NAME POWER ROCKER SWITCH 13.0mmX19.2mm PANEL SIZE SPDT, 3 TERMINALS, NON-ILLUMINATED	
0 PLC ± -		PRODUCT SPEC	NOT APPLICABLE	SIZE	A2
1 PLC ± 0.30		APPLICATION SPEC	NOT APPLICABLE	CAGE CODE	00779
2 PLC ± 0.05		WEIGHT	-	DRAWING NO	C=1571079
3 PLC ± -		MATERIAL	-	RESTRICTED TO	-
4 PLC ± -		FINISH	-	SCALE	3:1
ANGLES ± -		CUSTOMER DRAWING		SHEET	2 of 3
FINISH		CUSTOMER DRAWING		REV	N

REVISIONS				
P	LTR	DESCRIPTION	DATE	APVD
-	-	SEE SHEET 1	-	-

ALCOSWITCH PART NUMBER

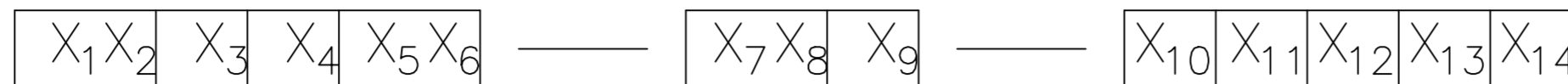

SWITCH TYPE: X₁X₂ = PR - POWER ROCKER

NOMINAL PANEL CUT OUT SIZE: X₃ = A - 13.0x19.2

NUMBER OF POLES: X₄ = S - SINGLE

SWITCH FUNCTION: X₅X₆ = D1 - ON-ON WITH OPAQUE, SINGLE-COLOR ROCKER BUTTON
D2 - ON-(ON) WITH OPAQUE, SINGLE-COLOR ROCKER BUTTON
D3 - ON-OFF-ON WITH OPAQUE, SINGLE-COLOR ROCKER BUTTON
D4 - ON-OFF-(ON) WITH OPAQUE, SINGLE-COLOR ROCKER BUTTON
D5 - (ON)-OFF-(ON), WITH OPAQUE, SINGLE-COLOR ROCKER BUTTON

CURRENT RATING: X₇X₈ = 16 - 6

TERMINAL TYPE: X₉ = E - FASTON™ TAB
L - SOLDER LUG

FRAME COLOR: X₁₀ = B - BLACK
W - WHITE

ROCKER COLOR: X₁₁ = B - BLACK
G - GREEN
R - RED
W - WHITE

SECONDARY ROCKER COLOR: X₁₂ = ∅ - NOT APPLICABLE
B - BLACK
G - GREEN
R - RED
W - WHITE

LEGEND TEXT PATTERN: X₁₃ =

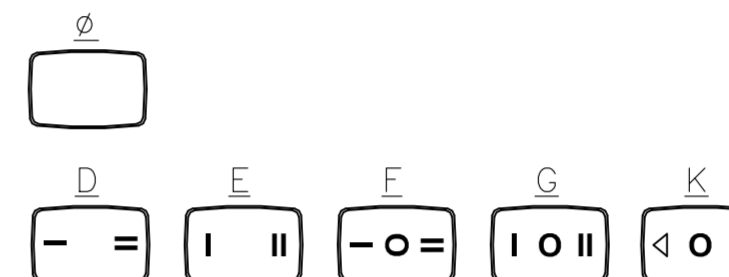

LEGEND TEXT COLOR: X₁₄ = ∅ - NOT APPLICABLE
G - GREEN
R - RED
B - BLACK
W - WHITE

1 MATERIALS:
 ROCKER BUTTON & HOUSING FRAME: NYLON 66, UL 94 V-2.
 TERMINAL, ACTIVE CONTACTOR: COPPER ALLOY PER ASTM B152/B152M
 PLUNGER: COPPER ALLOY PER ASTM B036
 PHENOLIC, UL94V1(SWITCH FUNCTION D5 ONLY)
 SPRING: STEEL WIRE PER ASTM A228/A228M
 CONTACT: SILVER-TIN OXIDE

6 UL: 16(4)A 125/250VAC / 16A12VDC 6A28VDC
 ENEC: 10A 125V~, 6(3)A 250V~, μ25T85

7 ELECTRICAL RATINGS, APPROVED AGENCY LOGOS, TERMINAL IDENTIFICATION NUMBERS, MOLDED APPROXIMATELY AS SHOWN ON THE SIDE.

8 COMPONENT RECOGNIZED TO US & CANADIAN STANDARDS, UL FILE NO. E46765.

9 NOTE REMOVED.

10 TE CONNECTIVITY LOGO LOCATED APPROXIMATELY AS SHOWN PER TEC 202-36

2 FINISH:
 TERMINAL, ACTIVE CONTACTOR: 1.0μm MIN SILVER
 COPPER ALLOY PLUNGER: 3.0μm MIN NICKEL

3 ELECTRICAL SPECIFICATIONS:
 CURRENT AND VOLTAGE: **6**
 CONTACT RESISTANCE (INITIAL): <100mΩ (5V, 1A DC)
 DIELECTRIC STRENGTH (INITIAL): >1000 VAC, 1 MINUTE
 INSULATION RESISTANCE (INITIAL): >100MΩ MIN (500VDC BETWEEN OPEN CONTACTS)
 INRUSH CURRENT: 50A / 3msec (CAPACITIVE LOAD)
 ELECTRICAL LIFE ENDURANCE: >6000 OPERATIONS, VOLTAGE DROP: <100mV
 TEMPERATURE RISE AT TERMINALS: <30°C, 6000 OPERATIONS (AMBIENT CONDITIONS: 25±2°C AND 65±5%R.H)

4 MECHANICAL SPECIFICATIONS:
 ACTUATING FORCE: 150g MIN, 650g MAX
 OPERATING LIFE ENDURANCE: >100,000 OPERATIONS
 TERMINAL RETENTION STRENGTH: >2.5kg- SOLDER LUG
 >6.8kg- FASTON TAB

5 ENVIRONMENTAL SPECIFICATIONS:
 AMBIENT TEMPERATURE: -20°C TO +85°C
 HUMIDITY: MAX 85%
 SALT SPRAY: NO REMAKABLE RUST IN METAL PARTS. (5%SALT / 35°C 24HRS)
 SHOCK: NO MECHANICAL DEFECT OR DAMAGE. (100g / 10MSEC/ X,Y,Z 3 TIMES)
 VIBRATION: NO MECHANICAL DEFECT OR DAMAGE. (10-55Hz /1.5mm/ X,Y,Z 2HRS)

	16.5	23.5	2	PRASD5-16F-BB0KW	1-1571079-6
OBSOLETE	16.5	23.5	2	PRASD4-16F-BB0GW	1-1571079-5
	16.5	23.5	2	PRASD4-16F-BB0FW	1-1571079-4
OBSOLETE	16.5	23.5	2	PRASD4-16F-BB000	1-1571079-3
	13.8	20.9	1	PRASD2-16F-BB0EW	1-1571079-2
	13.8	20.9	1	PRASD2-16F-BB0DW	1-1571079-1
	13.8	20.9	1	PRASD2-16F-BB000	1-1571079-0
	16.5	23.5	2	PRASD3-16F-BB0GW	1571079-9
OBSOLETE	16.5	23.5	2	PRASD3-16F-BB0FW	1571079-8
	16.5	23.5	2	PRASD3-16F-BB000	1571079-7
OBSOLETE	13.8	20.9	1	PRASD1-16F-BB0EW	1571079-6
OBSOLETE	13.8	20.9	1	PRASD1-16F-BB0DW	1571079-5
	13.8	20.9	1	PRASD1-16F-BB000	1571079-4
	B	A	SHEET REF.	ALCOSWITCH PART NUMBER	PART NUMBER

THIS DRAWING IS A CONTROLLED DOCUMENT. DWN M.BINNER 25FEB2002
 CHK J.MOSIER
 APVD -
 NAME -
 PRODUCT SPEC -
 APPLICATION SPEC -
 NOT APPLICABLE
 NOT APPLICABLE
 NOT APPLICABLE

TE Connectivity Ltd.
TE
 POWER ROCKER SWITCH 13.0mmX19.2mm
 PANEL SIZE SPDT, 3 TERMINALS, NON-ILLUMINATED

SIZE A2 CAGE CODE 00779 DRAWING NO. C=1571079 RESTRICTED TO -
 WEIGHT -
 CUSTOMER DRAWING SCALE 3:1 SHEET 3 OF 3 REV N