

REVISIONS

REV	ECO	DESCRIPTION	DATE	BY	APPR
A1	-	RELEASE NEW DRAWING	29/MAR/22	MILO	TOMMY

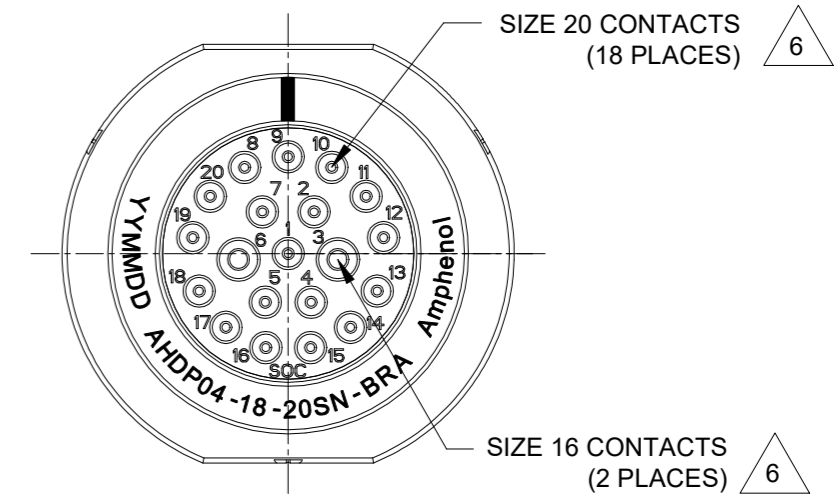
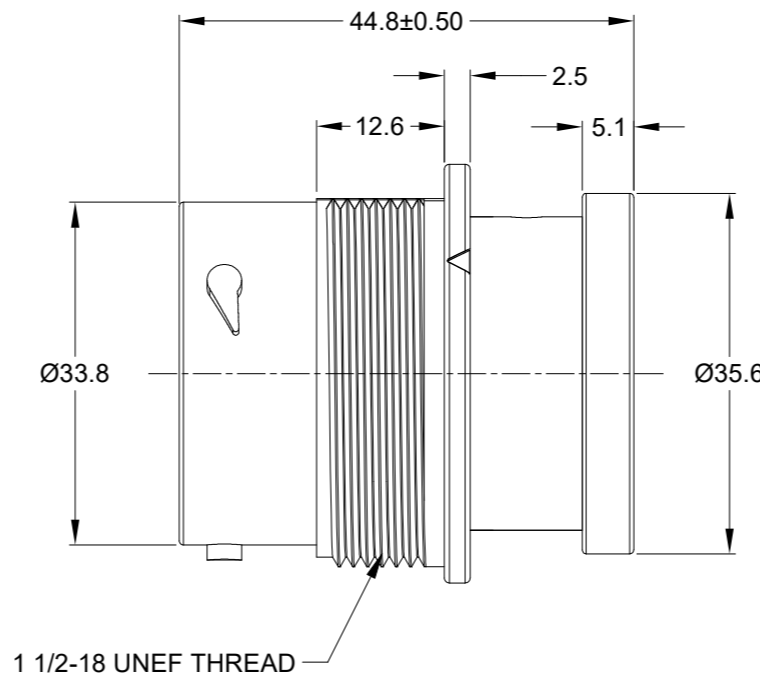
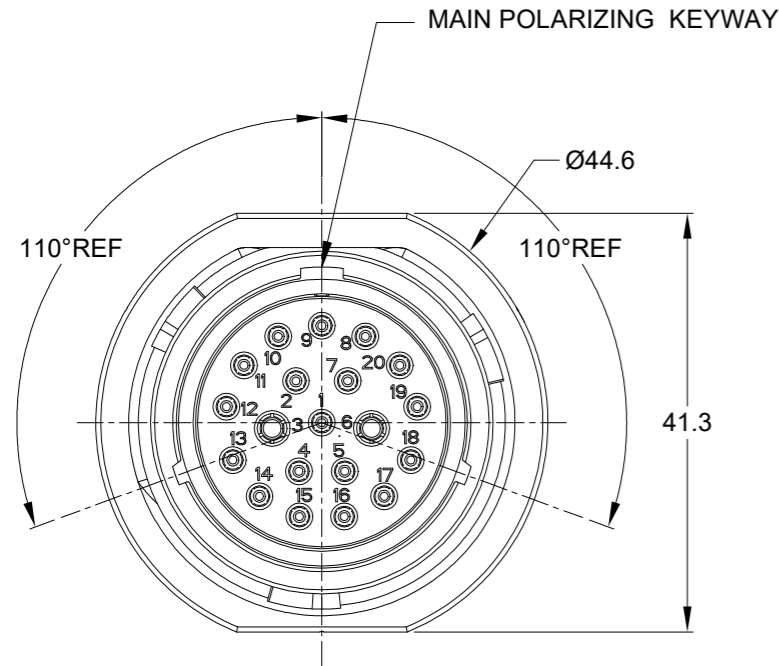

NOTES: UNLESS OTHERWISE SPECIFIED

- MATERIAL:
HOUSING: THERMOPLASTIC; BLACK
SEAL: SILICONE RUBBER
- MODIFICATIONS: BACKSHELL RING ADAPTER (BRA);
STANDARD DIA. WIRE SEAL;
- SPECIFICATIONS:
3.1 OPERATING TEMPERATURE: -55°C TO +125°C.
3.2 DIELECTRIC WITHSTANDING VOLTAGE: LESS THAN 2 MILLIAMPS CURRENT LEAKAGE @ 1500 VOLTS AC.
3.3 INSULATION RESISTANCE: 1000 MEGOHM MIN @ 25°C.
3.4 MOISTURE RESISTANCE:
IP68(IM OF WATER FOR A PERIOD OF 24 HOURS, MATED CONDITION);
IP69K(MATED CONDITION).
3.5 MATING CYCLE DURABILITY: 100 CYCLES
3.6 RoHS COMPLIANT
- MATING PART: AHDP06-18-20P* (* = SEAL TYPE)
- ALL DIMENSIONS ARE FOR REFERENCE USE ONLY.

△ CONTACT SIZE AND WIRE RANGE:

CONTACT SIZE	MIN. INSUL O.D.	MAX. INSUL O.D.	TYPICAL WIRE RANGE	CURRENT RATING
20	1.02 mm (.040in)	2.41 mm (.095 in)	16-22 AWG (1.5-0.5mm ²)	7.5 AMPS
16	2.54 mm (.100in)	3.40mm (.134 in)	14-20 AWG (2.0-0.5mm ²)	13 AMPS

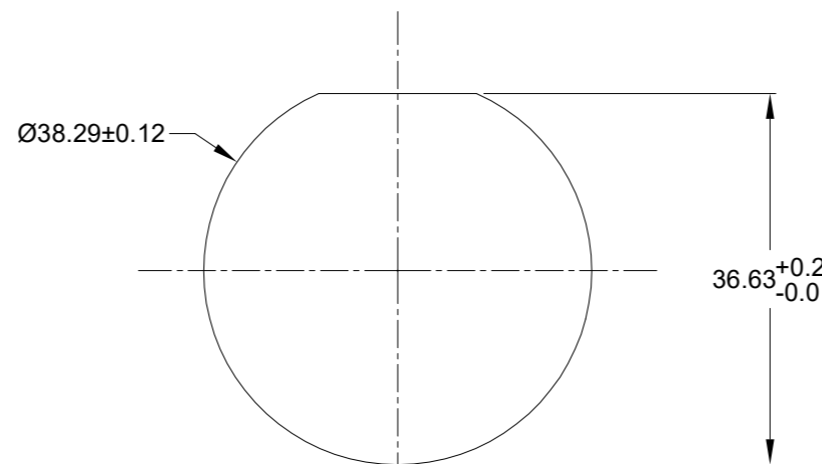

RECOMMENDED PANEL MOUNTING HOLE

RECOMMENDED PANEL THICKNESS: 1.6 TO 4.7MM

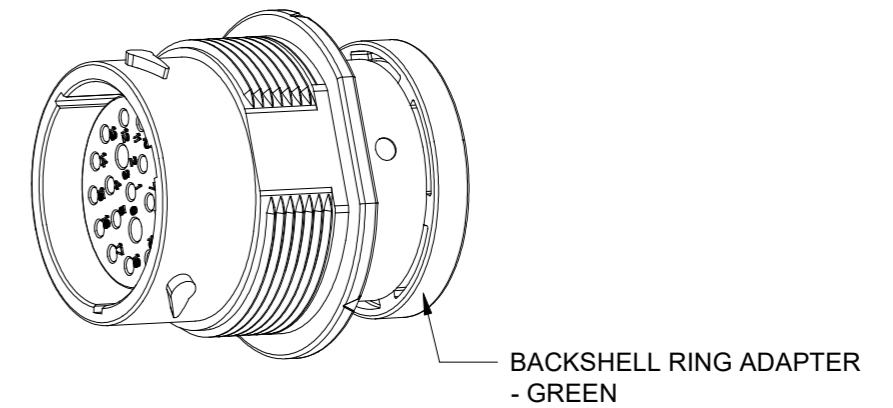

QUANTITY	AHDP04-18-20SN-BRA	DESCRIPTION	ITEM

MATERIALS LIST			
SIGNATURES	DATE		
DRAWN: MILO	29/MAR/22	<h1>Amphenol</h1> <p>Sine Systems - www.amphenol-sine.com 44724 Morley Drive Clinton Township, MI 48036</p>	
CHECKED: SULLEN	30/MAR/22		
ENGINEER:			
APPROVAL: TOMMY	31/MAR/22	20POS, RECEPTACLE, SOCKET, SIZE 18, NORMAL SEAL, BRA, DURAMATE AHDP	
MATERIAL SPECIFICATIONS:	CUSTOMER:		
WEIGHT: 42.6g			
PROCESS SPECIFICATIONS:	THIS DRAWING IS SUPPLIED FOR INFORMATION ONLY. DESIGN FEATURES, SPECIFICATIONS AND PERFORMANCE DATA SHOWN HEREON ARE THE PROPERTY OF THE AMPHENOL CORPORATION. NO RIGHTS OF REPRODUCTION ARE IMPLIED. ALL DIMENSIONS ARE SUBJECT TO NORMAL MANUFACTURING VARIATIONS.		
NEXT ASSY:			

SIZE	TYPE	DWG NO.	REVISION
B	C-	AHDP04-18-20SN-BRA	A1

SCALE	SHEET	OF
NONE	1	1

TITLE: 20POS, RECEPTACLE, SOCKET, SIZE 18, NORMAL SEAL, BRA, DURAMATE AHDP
DWG NO: AHDP04-18-20SN-BRA
REV: A1
SH: 1
OF: 1