

C30902EH and C30921EH Avalanche Photodiodes

Low Noise Reach-Through APD for low light level detection



Excelitas' C30902EH Avalanche Photodiodes are high speed, large area Silicon Reach-Through APDs that provide high responsivity at low noise. They are especially designed for low light applications that require typical gains larger than 100 and are offered within several TO-18 package configurations as flat glass, ball lens, light pipe and 905 nm filter.

Key Features

- Spectral response 400 nm – 1100 nm
- Low Dark Current
- Low Noise at Room Temperature
- High quantum efficiency of 84% at 800 nm
- Large active area with diameter of 500 μm
- RoHS compliant

Applications

- LiDAR / ToF measurements
- Small-signal fluorescence
- Optical time-domain reflectometer (OTDR)
- Laser scanning

All specifications are referring to an ambient temperature of $T_A = 22\text{ }^\circ\text{C}$, $\lambda = 800\text{ nm}$ and a gain of $M = 150$ unless otherwise specified.

Table 1: Key parameters

Parameter	Symbol	Minimum	Typical	Maximum	Unit
Breakdown Voltage	V_{BD}	185	225	260	V
Spectral Range	$\Delta\lambda$	400		1100	nm
Peak Responsivity	λ_{peak}		800		nm
Quantum Efficiency ¹	QE		84		%

Note 1: Quantum Efficiency is not a directly measurable quantity. The above specified typical parameter is linked to the typical responsivity by $QE = \frac{1240R}{\lambda M}$

C30902EH and C30921EH Avalanche Photodiodes

Low Noise Reach-Through APD for low light level detection

Table 2: Ordering Information

Parameter	C30902EH	C30902EH-2	C30902BH	C30921EH
Reach-Through APD			X	
Geiger Mode SPAD ¹				
Ball Lens			X	
Flat Glass Window	X	X		X
Active Area Shape			Circular	
Useful Area			0.2 mm ²	
Useful Diameter			0.5 mm	
905 nm Filter		X		
TO-18 package			X	
Light Pipe				X

Note 1: Please refer to the C30902SH datasheet for photon counting applications in the Geiger Mode.

Table 3: Absolute Maximum Ratings

Parameter	Symbol	Condition	Value	Units
Forward Current	I_F	RMS	5	mA
		Single Peak, 1 s	50	
Total Power dissipation	P_{tot}		60	mW
Reverse Current	I_R	RMS	0.2	mA
		Single Peak, 1s	1	
Storage Temperature	T_S		-60 ... 100	°C
Operating Temperature	T_{Op}		-40 ... 85	

Note 1: Stresses above those listed under “Absolute Maximum Ratings” may cause permanent damage to the device.

Note 2: Exposure to absolute maximum rating conditions for extended periods may affect device reliability.

C30902EH and C30921EH Avalanche Photodiodes

Low Noise Reach-Through APD for low light level detection

Table 4: Electrical Specifications

Parameter	Symbol	Minimum	Typical	Maximum	Units
Recommended Operating Gain	M		150		
Responsivity	R	70	80		A/W
Rise Time / Fall Time ¹	t _r / t _f		0.4		ns
Bandwidth	f _{3dB}		800		MHz
Temperature Coefficient of V _{BD}	ΔV/ΔT	0.5	0.7	0.9	V/°C
Capacitance	C		1.5	1.8	pF
Dark Current ²	i _D		7	10	nA
Dark Noise ³	i _N		0.1	0.25	pA/√Hz
Noise Equivalent Power ⁴	NEP		1.23		fW/√Hz

Note 1: As estimated by $t_{r/f} = \frac{0.35}{f_{3dB}}$

Note 2: Surface (i_{DS}) and bulk (i_{DB}) dark current are contributing to the total dark current by $i_D = i_{DS} + i_{DB}M$.

Note 3: Due to the natural fluctuations of amplified charge carriers the APD will also generate noise when not illuminated. Since the noise characteristics and hence the signal-to-noise ratio (SNR) are depending on the bandwidth (B) and used wavelength (λ) inside the final system the illuminated noise

$$i_{ill} = \sqrt{2qB[i_{DS} + (i_{DB}M^2 + R_0(\lambda)M^2P)F]}$$

needs to be considered. Hence the SNR defines as: $SNR = \frac{i_P^2}{i_{ill}^2} = \frac{(PR_0(\lambda)M)^2}{i_{ill}^2}$ with P the incident optical power in W, R₀(λ) the intrinsic (M = 1) responsivity in A/W, q the charge carrier and F the excess noise factor (ENF).

It is not recommended to use approximations like $F = M^x$ as this method gives erroneously results versus actual measurements of an APD, particularly when operated at gains that are differing from the specified gain in the datasheet. The ENF at a certain gain is depending on the k-factor k_{eff}, a material property of the APD, which for the C30902SH series is k_{eff} = 0.02.

For more information see also :

Philippe Bérard, Martin Couture, and Richard J. Seymour "Excess noise factor of front and back-illuminated silicon avalanche photodiode", Proc. SPIE 11388, Image Sensing Technologies: Materials, Devices, Systems, and Applications VII, 113880P (23 April 2020)

$$F(M, k_{eff}) = k_{eff}M + (2 - \frac{1}{M})(1 - k_{eff})$$

Note 4: The NEP is specified in dark conditions as $NEP = \frac{i_N}{R(\lambda)}$

C30902EH and C30921EH Avalanche Photodiodes

Low Noise Reach-Through APD for low light level detection

Table 5: Optical Specifications C30902EH-2

Parameter	Symbol	Minimum	Typical	Maximum	Unit
Spectral Range	$\Delta\lambda_{905}$	860		960	nm
Responsivity ¹	R_{905}	55	66		A/W
Peak Responsivity	$\lambda_{peak,905}$		905		nm
Quantum Efficiency ¹	QE_{905}		60		%

Note 1: At $\lambda = 905$ nm

Table 6: Aperture Specifications

Parameter	C30902EH	C30902BH	C30902EH-2	C30921EH	Units
Field of view α	90	90	55	33	°
Field of view α'	114	114	78		°

Figure 1: Field of view definition

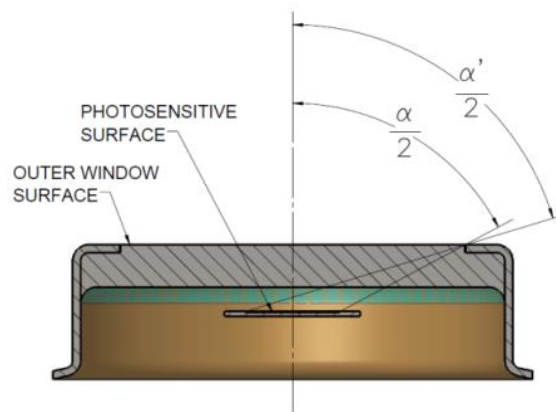

VS-383

C30902EH and C30921EH Avalanche Photodiodes

Low Noise Reach-Through APD for low light level detection

Figure 2: TO-18 Dimensions C30902EH

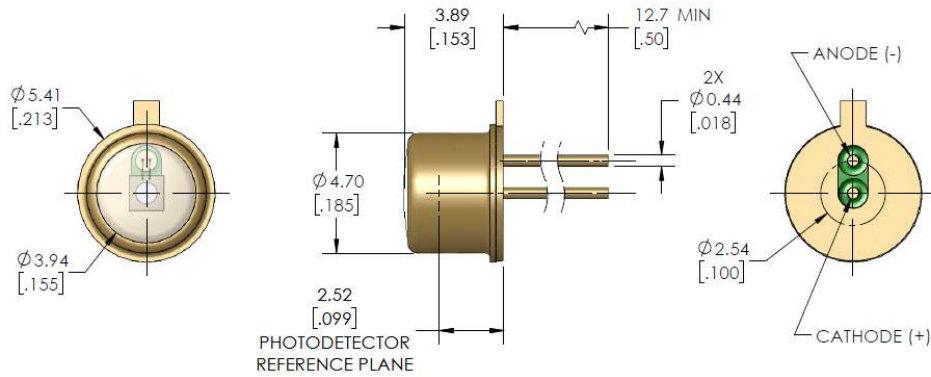

DIMENSIONS ARE IN MILLIMETERS [INCHES]
AND ARE FOR REFERENCE ONLY

Figure 3: TO-18 Dimensions C30902EH-2

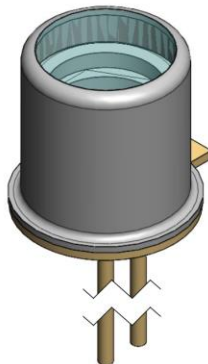
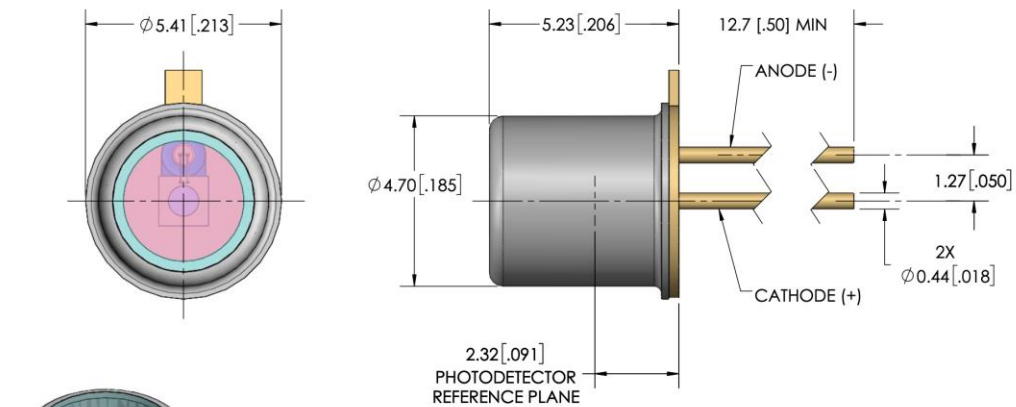

DIMENSIONS ARE IN MILLIMETERS [INCHES]
AND ARE FOR REFERENCE ONLY

C30902EH and C30921EH Avalanche Photodiodes

Low Noise Reach-Through APD for low light level detection

Figure 4: TO-18 Dimensions C30902BH

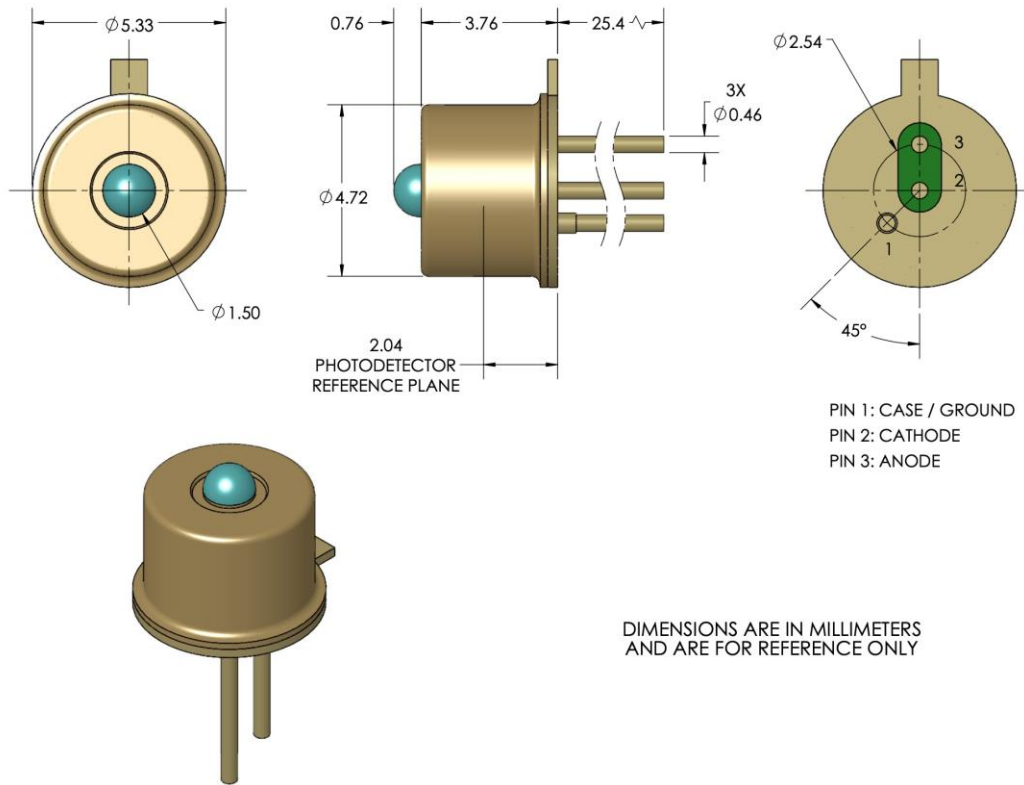
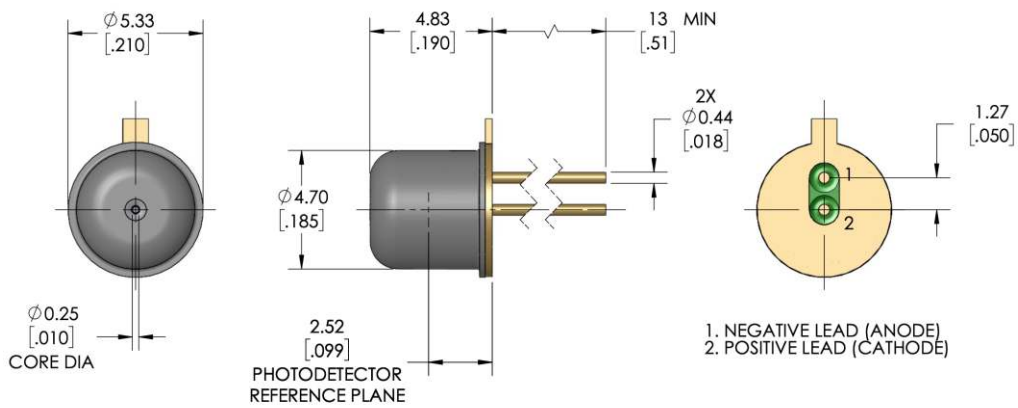

Figure 5: TO-18 Dimensions C30921EH



C30902EH and C30921EH Avalanche Photodiodes

Low Noise Reach-Through APD for low light level detection

Figure 6: Typical Responsivity

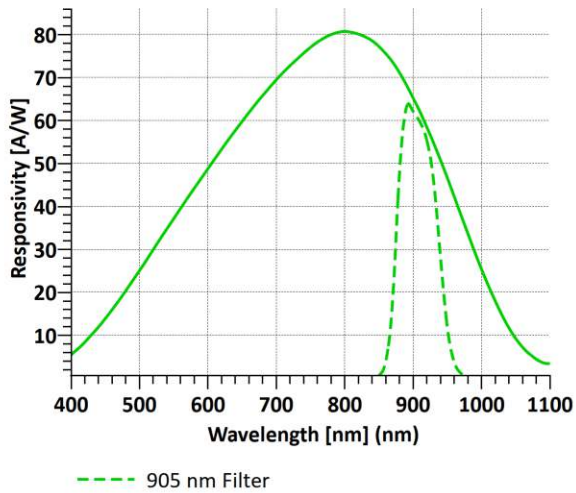

Figure 7: Typical Quantum Efficiency

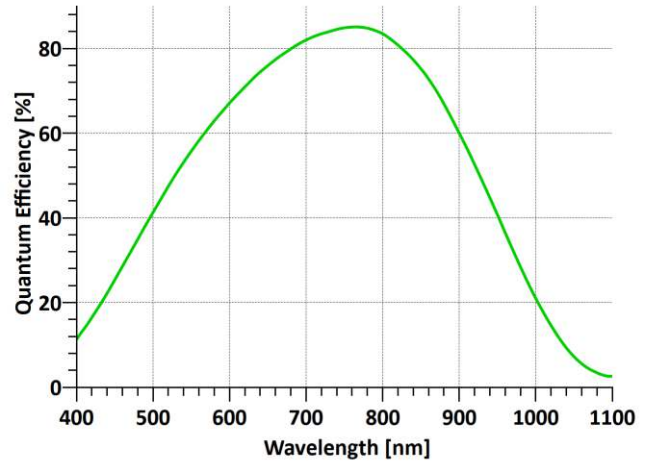

Figure 8: Typical Gain and Dark Current

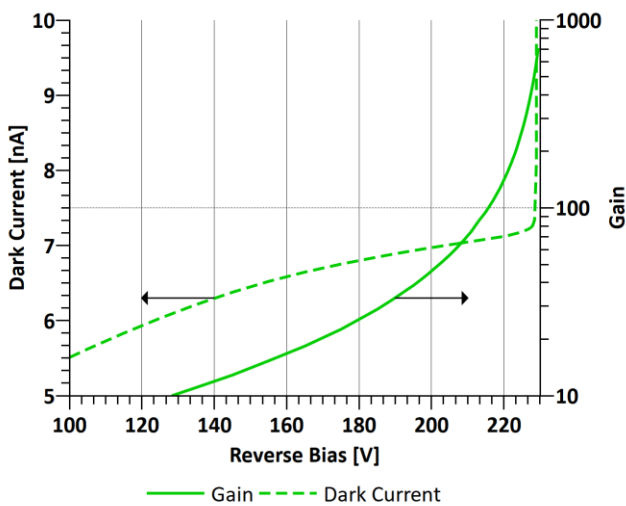

Figure 9: Typical Capacitance

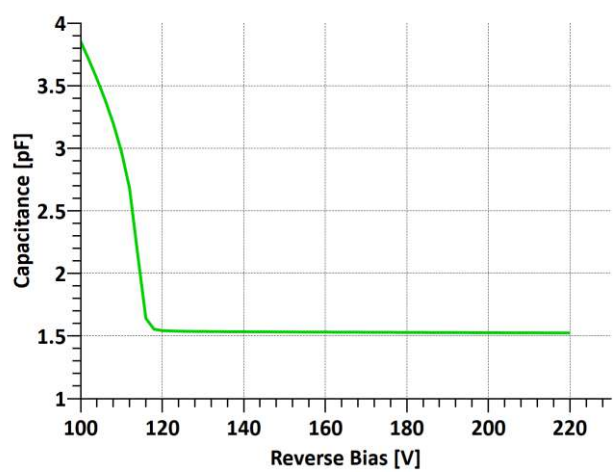
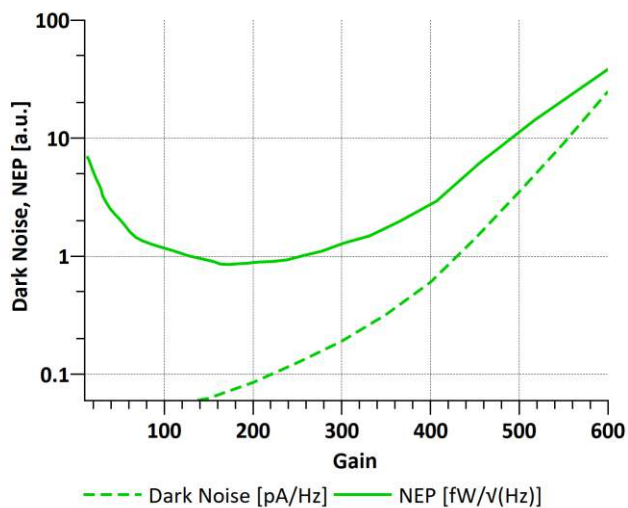

Figure 10: Typical Noise Parameter vs. Gain



C30902EH and C30921EH Avalanche Photodiodes

Low Noise Reach-Through APD for low light level detection

Information

Excelitas Technologies' C30902EH series of avalanche photodiodes is fabricated with a double-diffused "reach-through" structure. This structure provides high responsivity between 400 nm and 1000 nm as well as extremely fast rise and fall times at all wavelengths. The responsivity of the device is independent of a modulation frequency up to about 800 MHz. The detector chip is hermetically-sealed behind a flat glass window in a modified TO-18 package. The useful diameter of the photosensitive surface is 0.5 mm.

The C30921EH is packaged in a lightpipe TO-18 which allows efficient coupling of light to the detector from either a focused spot or an optical fiber up to 0.25 mm in diameter. The hermetically-sealed TO-18 package allows fibers to be mated to the end of the lightpipe to minimize signal losses without fear of endangering detector stability. The C30902EH-2, with hermetic TO-18 package with inline 905nm passband filter and the C30902BH, with hermetic ball lens, complete the C30902EH series.

The family of the C30902 APD series features also an Single Photon capable APD (SPAD) that can be operated in Geiger Mode and linear mode at substantial higher gains. Please refer to our C30902SH Datasheet for further information.

Testing methods

Excelitas verifies the electro optical specifications on every device. Hence, a specific voltage, V_{OP} , is supplied with each device. When the photodiode is operated at this voltage (at 22 °C), it will meet the electrical specifications shown above. The voltage will be lower as the breakdown voltage V_{BD} .

Visual inspection during fabrication is performed as per our quality standard and failed diodes are removed. Excelitas Technologies is certified to meet ISO-9001 and our products are designed to meet MIL-STR-883 and/or MIL-STD-750 specifications.

The following parameters are part of Excelitas testing procedures

- Operating Voltage
- Breakdown Voltage
- Dark Current
- Responsivity @ 830 nm
- Dark Noise

Packaging and shipping

The C3902EH series APDs are shipped in ESD safe plastic trays.

C30902EH and C30921EH Avalanche Photodiodes

Low Noise Reach-Through APD for low light level detection

Storage and handling

Excelitas highly recommends to follow the below notes:

- Keep APDs in a ESD controlled environment until final assembly.
- Keep the trays closed until final assembly.
- Remove APDs from tray by using a non-metallic, ESD safe tweezer.

RoHS Compliance

This series of APD diodes are designed and built to be fully compliant with the European Union Directive on restrictions of the use of certain hazardous substances in electrical and electronic equipment.



Warranty

A standard 12-month warranty following shipment applies.

About Excelitas Technologies

Excelitas Technologies is a global technology leader focused on delivering innovative, customized solutions to meet the lighting, detection and other high-performance technology needs of OEM customers.

Excelitas has a long and rich history of serving our OEM customer base with optoelectronic sensors and modules for more than 45 years beginning with PerkinElmer, EG&G, and RCA. The constant throughout has been our innovation and commitment to delivering the highest quality solutions to our customers worldwide.

From aerospace and defense to analytical instrumentation, clinical diagnostics, medical, industrial, and safety and security applications, Excelitas Technologies is committed to enabling our customers' success in their specialty end-markets. Excelitas Technologies has approximately 7,000 employees in North America, Europe and Asia, serving customers across the world.

Excelitas Technologies

22001 Dumberry Road
Vaudreuil-Dorion, Quebec
Canada J7V 8P7
Telephone: (+1) 450.424.3300
Toll-free: (+1) 800.775.6786
Fax: (+1) 450.424.3345

Excelitas Technologies

GmbH & Co. KG
Wenzel-Jaksch-Str. 31
D-65199 Wiesbaden
Germany
Telephone: (+49) 611 492 430
Fax: (+49) 611 492 165

Excelitas Technologies Singapore, Pte. Ltd.

8 Tractor Road
Singapore 627969
Telephone: (+65) 6775 2022 (Main number)
Telephone: (+65) 6770 4366 (Customer Service)
Fax: (+65) 6778-1752



Contact us at <http://www.excelitas.com/contact>

For a complete listing of our global offices, visit www.excelitas.com/locations

© 2022 Excelitas Technologies Corp. All rights reserved. The Excelitas logo and design are registered trademarks of Excelitas Technologies Corp. All other trademarks not owned by Excelitas Technologies or its subsidiaries that are depicted herein are the property of their respective owners. Excelitas reserves the right to change this document at any time without notice and disclaims liability for editorial, pictorial or typographical errors.