

FCI PART NUMBER	DESCRIPTION	NOTES
10127773-XXXXLF	CONTROLLER TO CONTROLLER CONFIGURATION	SEE TABLE 1

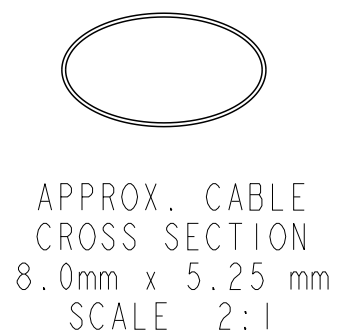
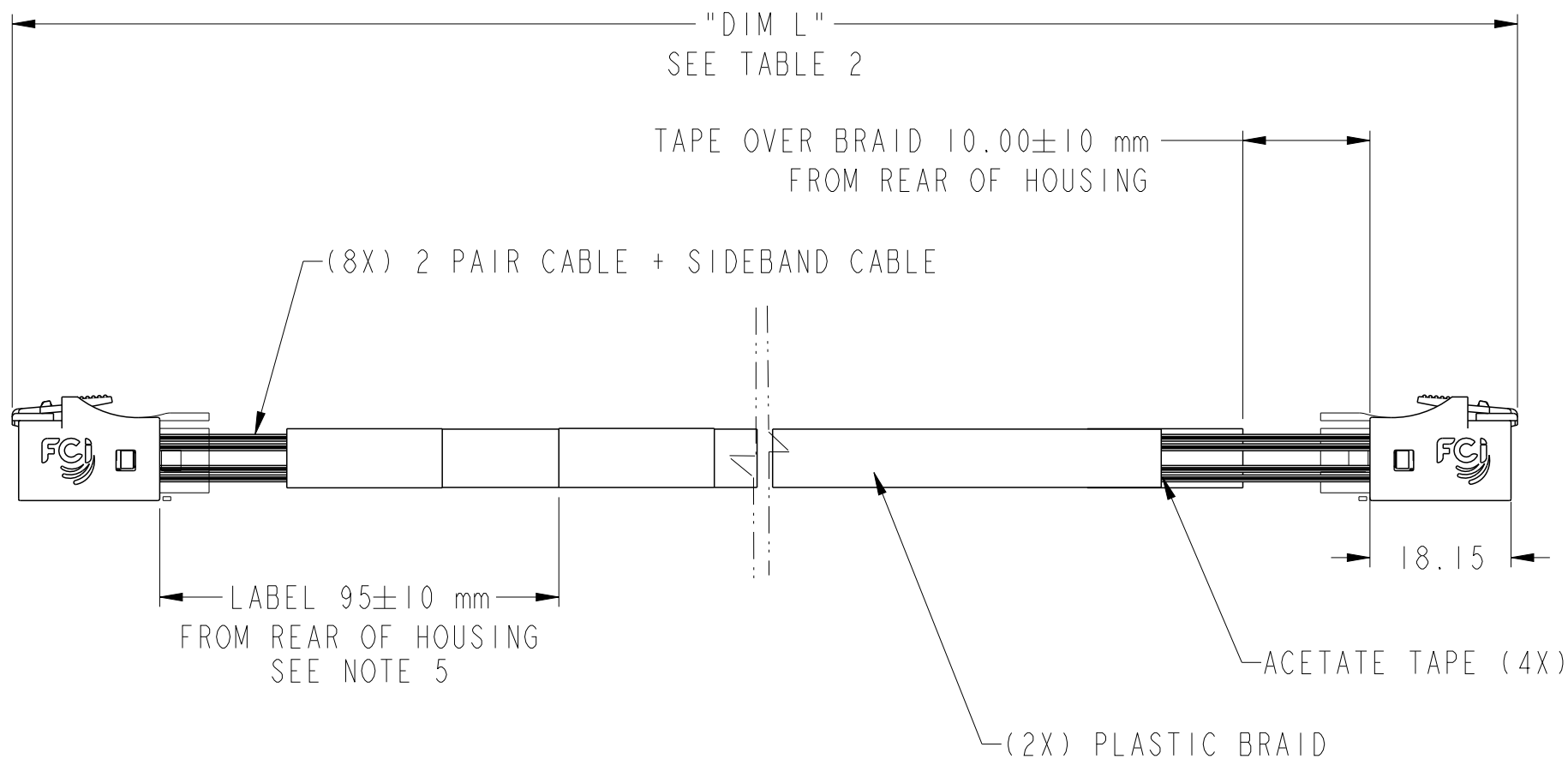
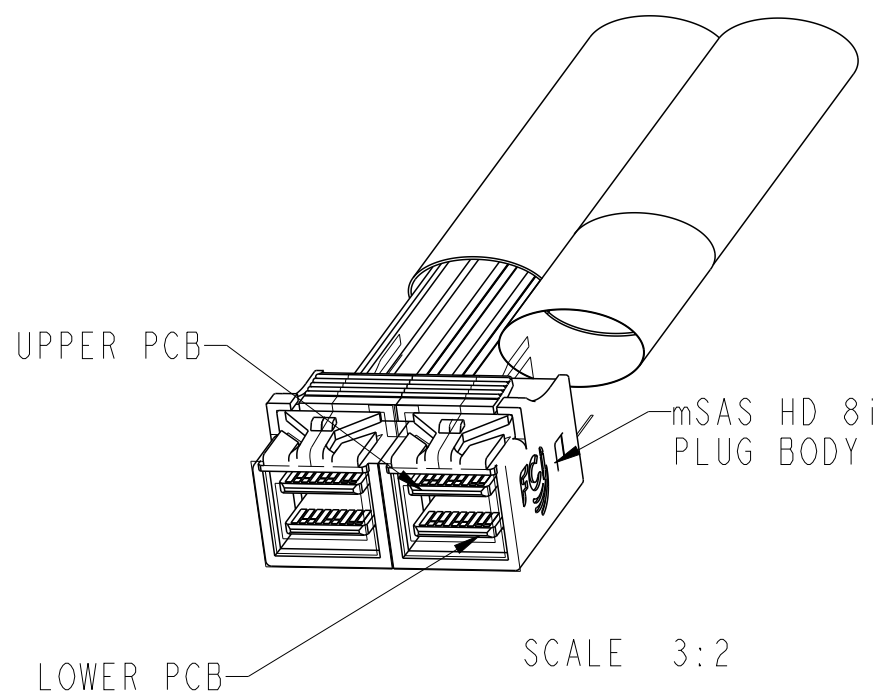

spec ref	-	dr	Jason Gu	2013/10/24	projection	mm	size	A3	scale	1:1	
tolerance std	ISO 406 ISO 1101	eng	Jason Gu	2013/10/30			ecn no	-	rel level	Released	
TOLERANCES UNLESS OTHERWISE SPECIFIED		chr	-	2013/10/30							product family
surface	ISO 1302	linear	0.X	±0.3		title mSAS HD INTERNAL (8i) CABLE ASSEMBLY- 6 Gb/s	dwg no 10127773	rev A	Product - Customer Drw		
		angular	0°	±2°					cat. no.	-	sheet 1 of 4
									www.fci.com		

FCI PART NUMBER	DESCRIPTION	NOTES
10127773-XXXXLF	CONTROLLER TO CONTROLLER CONFIGURATION	SEE TABLE 1

TABLE 1 - CABLE PART NUMBER LIST			
PART NUMBER	"DIM L" CABLE LENGTH (METERS)	AWG	NOTES
10127773-2030LF	0.3	30	CONTROLLER TO CONTROLLER WIRING CONFIGURATION (SHEET 2) ----- (SEE SHEET 3 FOR ALL NOTES)
10127773-2040LF	0.4	30	
10127773-2050LF	0.5	30	
10127773-2060LF	0.6	30	
10127773-2070LF	0.7	30	
10127773-2080LF	0.8	30	
10127773-2090LF	0.9	30	
10127773-2100LF	1.0	30	

NOTE:
1. ALL CABLE PERFORMANCE COMPLIANT SAS2.1
2. CABLE MORE THAN 1M COULD NOT MEET INSERTION LOSS -6dB MAX.

spec ref	-	dr	Jason Gu	2013/10/24	projection	mm	size	A3	scale	1:1
tolerance std	ISO 406 ISO 1101	eng	Jason Gu	2013/10/30			ecn no	-	rel level	Released
TOLERANCES UNLESS OTHERWISE SPECIFIED		chr	-	-			product family	-	rel level	Released
surface	<input checked="" type="checkbox"/> linear <input type="checkbox"/> angular	0.X	±0.3		mSAS HD INTERNAL (8i) CABLE ASSEMBLY- 6 Gb/s	dwg no 10127773	rev A	Product - Customer Drw		
ISO 1302	0.XX	±0.10	cat. no.					-	sheet 2 of 4	
	0.XXX	±0.005								
	angular	0°	±2°	www.fci.com						



Copyright FCI.

FCI PART NUMBER	DESCRIPTION	NOTES
10127773-XXXXLF	CONTROLLER TO CONTROLLER CONFIGURATION	SEE TABLE 1

P1-(A) TO P2-(A)
P1-(B) TO P2-(B)

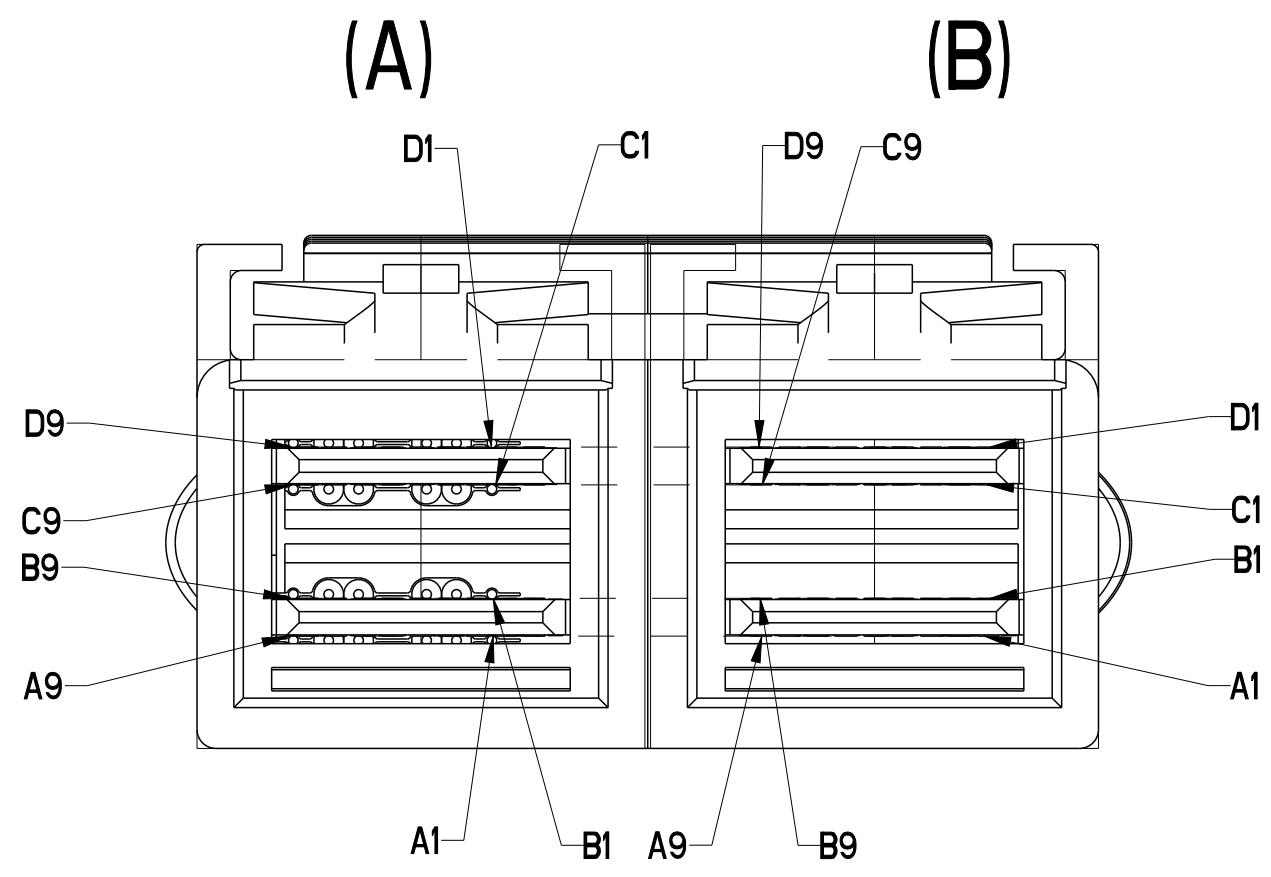

SCALE 5:1

LEGEND	
	HIGH-SPEED SERIAL DIFFERENTIAL PAIRS
	SIGNAL RETURN
	SIDEBAND SIGNAL

WIRING LIST (CONTROLLER TO CONTROLLER)				
END P1 A/B (CONTROLLER)			END P2 A/B (CONTROLLER)	
POSITION	SYMBOL		POSITION	SYMBOL
D9	GROUND	-----	B9	GROUND
D8	Tx2-		B8	Rx2-
D7	Tx2+		B7	Rx2+
D6	GROUND	-----	B6	GROUND
D5	Tx0-		B5	Rx0-
D4	Tx0+		B4	Rx0+
D3	GROUND	-----	B3	GROUND
D2	SIDEBAND 6		B2	SIDEBAND 1
D1	SIDEBAND 5		C2	SIDEBAND 2
C1	SIDEBAND 4		B1	SIDEBAND 3
C2	SIDEBAND 2		D1	SIDEBAND 5
C3	GROUND	-----	A3	GROUND
C4	Tx1+		A4	Rx1+
C5	Tx1-		A5	Rx1-
C6	GROUND	-----	A6	GROUND
C7	Tx3+		A7	Rx3+
C8	Tx3-		A8	Rx3-
C9	GROUND	-----	A9	GROUND
B9	GROUND	-----	D9	GROUND
B8	Rx2-		D8	Tx2-
B7	Rx2+		D7	Tx2+
B6	GROUND	-----	D6	GROUND
B5	Rx0-		D5	Tx0-
B4	Rx0+		D4	Tx0+
B3	GROUND	-----	D3	GROUND
B2	SIDEBAND 1		D2	SIDEBAND 6
B1	SIDEBAND 3		C1	SIDEBAND 4
A1	SIDEBAND 7		A2	SIDEBAND 0
A2	SIDEBAND 0		A1	SIDEBAND 7
A3	GROUND	-----	C3	GROUND
A4	Rx1+		C4	Tx1+
A5	Rx1-		C5	Tx1-
A6	GROUND	-----	C6	GROUND
A7	Rx3+		C7	Tx3+
A8	Rx3-		C8	Tx3-
A9	GROUND	-----	C9	GROUND

spec ref	-	dr	Jason Gu	2013/10/24	projection	mm	size	A3	scale	2:1
tolerance std	ISO 406 ISO 1101	eng	Jason Gu	2013/10/30		← →	ecn no	-	rel level	Released
TOLERANCES UNLESS OTHERWISE SPECIFIED		chr	-	-						
surface	ISO 1302	appr	Roger Cheng	2013/10/30	product family	-	rel level	Released		
	linear	0.X	±0.3		title	mSAS HD INTERNAL (8i)	dwg no	10127773	rev	A
		0.XX	±0.10							
	angular	0°	±2°							
				www.fci.com	cat. no.	-	Product - Customer Drw	sheet 3 of 4		



Copyright FCI.

NOTES:

- 1. MATERIAL:
HOUSINGS: MODIFIED POLYPHENYLENE ETHER
PADDLE CARD: PRINTED CIRCUIT SUBSTRATE
HEAT SHRINK TUBE: POLYOLEFIN
EPOXY LOCTITE
- 2. THIS PRODUCT MEETS THE RESTRICTION OF HAZARDOUS SUBSTANCES IN ELECTRICAL AND ELECTRONIC EQUIPMENT (RoHS) DIRECTIVE (2002/95/EC)
- 3. THIS DIMENSION IS A FINISHED PRODUCT LENGTH.
- 4. UNLESS OTHERWISE SPECIFIED ASSEMBLED LENGTH TOLERANCE IS TO BE:
"DIM L" < 1 METER = ±15mm
"DIM L" 1 METER TO 10 METERS = ± 2% OF "DIM L"
- 5. UNLESS OTHERWISE SPECIFIED LABEL POSITION IS TO BE 95mm FROM REAR OF PI CONNECTOR.
LABEL DETAILS:
FCI CHINA
FCI P/N
REVISION
SN: CNYYWWGN * * * #####
(the first * present cable length, eg:03--0.3m, 04--0.4m...)
(the 2nd * present cable wire guage, eg:2--30awg)
(the 3th * present L--lead free or H--halongen free .)
(the ##### present serial number, eg: 0001, 0002...)

FONT SHALL BE CLEARLY VISIBLE AND BLACK IN COLOR.

- 6. ALL CABLE ASSEMBLIES SHALL BE 100% TESTED FOR CONTINUITY AS DEFINED IN WIRING LIST.
- 7. ALL CABLE ASSEMBLIES SHALL BE 100% HI-POT TESTED BH APPLYING 300V DC FOR A MINUMUM OF 10ms.
- 8. IMPEDANCE: 100Ω DIFFERENTIAL.
- 9. OTHER TESTING PERFORMED AS REQUIRED BY PRODUCT SPECIFICATION: GS-12-650.
- 10. PACKAGE AND LABEL CABLE ASSEMBLIES PER GS-14-1272.
- 11. A "△" SYMBOL WILL BE NEXT TO ANY DIMENSION, VIEW, OR NOTE WHICH HAS BEEN MODIFIED WITH THE CURRENT DRAWING REVISION. THE CURRENT REVISION WILL BE SHOWN IN THE SYMBOL.
- 12. "HLF" PRODUCT NUMBERS DESIGNATE THE USE OF HALOGEN FREE RAW CABLE.
- 13. HALOGEN FREE RAW CABLE CAN BE USED AS A SUBSTITUTE ON NON-HF PRODUCT NUMBERS.
- 14. PART NUMBER/SUPPLIER SUBSTITUTION IS NOT ALLOWED.
- 15. THIS PRODUCT CONFORMS TO THE MECHANICAL DIMENSIONING AND ELECTRICAL REQUIREMENTS OF THE SFF-8643 SPECIFICATION.
- 16. THIS PRODUCT CONFORMS TO THE SAS 2.1 SPECIFICATION.



Copyright FCI.

spec ref	-	dr	Jason Gu	2013/10/24	projection	mm	size	A3	scale	2:1
tolerance std	ISO 406 ISO 1101	eng	Jason Gu	2013/10/30		← →	ecn no		-	
TOLERANCES UNLESS OTHERWISE SPECIFIED		chr	-	-			rel level		Released	
surface	ISO 1302	appr	Roger Cheng	2013/10/30	product family	-	dwg no	10127773	rev	A
	linear	0.X	±0.3		mSAS HD INTERNAL (8i)					
		0.XX	±0.10		CABLE ASSEMBLY- 6 Gb/s					
		0.XXX	±0.005							
	angular	0°	±2°	www.fci.com	cat. no.	-	Product - Customer Drw		sheet 4 of 4	