

# TSL257

## High-Sensitivity Light-to-Voltage Converter

### General Description

The TSL257 is a high-sensitivity low-noise light-to-voltage optical converter that combines a photodiode and a transimpedance amplifier on a single monolithic CMOS integrated circuit. Output voltage is directly proportional to light intensity (irradiance) on the photodiode. The TSL257 has a transimpedance gain of 320M $\Omega$ . The device has improved offset voltage stability and low power consumption and is supplied in a 3-lead clear plastic sidelooker package with an integral lens. When supplied in the lead (Pb) free package, the device is RoHS compliant.

*Ordering Information and Content Guide appear at end of datasheet.*

### Key Benefits & Features

The benefits and features of TSL257, High-Sensitivity Light-to-Voltage Converter are listed below:

**Figure 1:**  
Added Value of Using TSL257

Benefits	Features
<ul style="list-style-type: none"> <li>Enables Extremely Fast Response to Change</li> </ul>	<ul style="list-style-type: none"> <li>Single Photo-Diode and Trans Impedance Architecture</li> </ul>
<ul style="list-style-type: none"> <li>Enables Fast Response to Visible Light in Range of 400nm to 700nm Wavelengths</li> </ul>	<ul style="list-style-type: none"> <li>160<math>\mu</math>s Output Rise-Time Response</li> </ul>
<ul style="list-style-type: none"> <li>Provides for High Sensitivity to Detect a Small Change in Light</li> </ul>	<ul style="list-style-type: none"> <li>High Irradiance Responsivity: Typically 1.68V/(<math>\mu</math>W/cm<sup>2</sup>) at <math>\lambda_p = 645</math>nm</li> </ul>
<ul style="list-style-type: none"> <li>Provides Additional Sensitivity Advantages</li> </ul>	<ul style="list-style-type: none"> <li>2x Gain Lens</li> </ul>
<ul style="list-style-type: none"> <li>Provides Full Dynamic Range</li> </ul>	<ul style="list-style-type: none"> <li>Rail-To-Rail Output Swing</li> </ul>

- Converts Light Intensity to Output Voltage
- Monolithic Silicon IC Containing Photodiode, Operational Amplifier, and Feedback Components
- High Sensitivity
- Single Voltage Supply Operation (2.7V to 5.5V)
- Low Noise (200 $\mu$ Vrms Typ to 1kHz)
- High Power-Supply Rejection (35dB at 1kHz)
- Compact 3-Leaded Plastic Package
- RoHS Compliant (-LF Package Only)

## Functional Block Diagram

The functional blocks of this device are shown below:

**Figure 2:**  
TSL257 Block Diagram

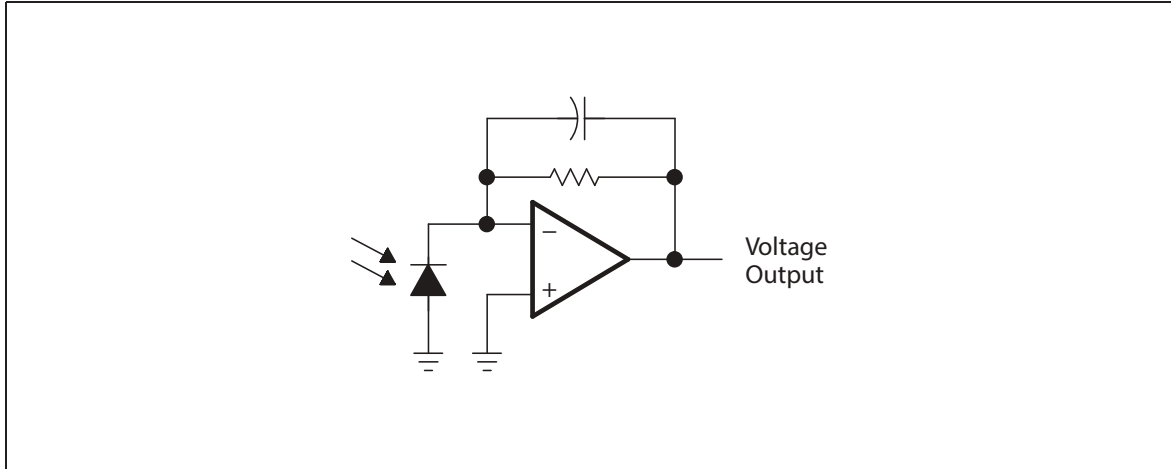

## Pin Assignment

The TSL257 pin assignments are described below.

**Figure 3:**  
Pin Diagram of Package S Sidelooker (Front View)

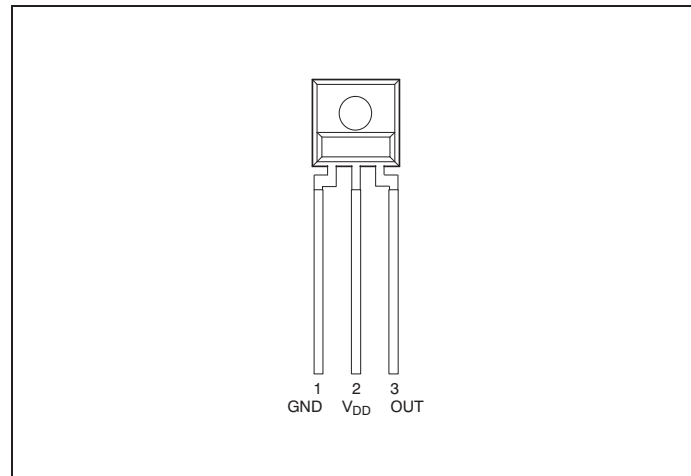

**Figure 4:**  
Pin Diagram of Package SM Surface Mount Sidelooker (Front View)

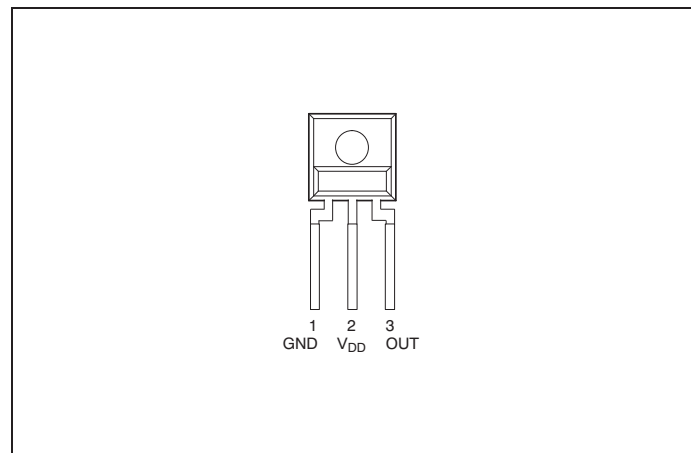

**Figure 5:**  
Terminal Functions

Terminal		Description
No.	Name	
1	GND	Ground (substrate). All voltages are referenced to GND.
2	V <sub>DD</sub>	Supply voltage
3	OUT	Output voltage

## Absolute Maximum Ratings

Stresses beyond those listed under [Absolute Maximum Ratings](#) may cause permanent damage to the device. These are stress ratings only. Functional operation of the device at these or any other conditions beyond those indicated under [Operating Conditions](#) is not implied. Exposure to absolute maximum rating conditions for extended periods may affect device reliability.

**Figure 6:**  
**Absolute Maximum Ratings over Operating Free-Air Temperature Range (unless otherwise noted)**

Symbol	Parameter	Min	Max	Unit
$V_{DD}$	Supply voltage <sup>(1)</sup>		6	V
$I_O$	Output current		±10	mA
	Duration of short-circuit current at (or below) 25°C		5	s
$T_A$	Operating free-air temperature range	-25	85	°C
$T_{STRG}$	Storage temperature range	-25	85	°C
	Lead temperature 1.6mm (1/16 inch) from case for 10 seconds (S Package)		260	°C
	Reflow solder, in accordance with J-STD-020C or J-STD-020D (SM Package)		260	°C

**Note(s):**

1. All voltages are with respect to GND.

## Electrical Characteristics

All limits are guaranteed. The parameters with min and max values are guaranteed with production tests or SQC (Statistical Quality Control) methods.

### Operating Conditions

All defined tolerances for external components in this specification need to be assured over the whole operation condition range and also over lifetime.

**Figure 7:**  
Recommended Operating Conditions

Symbol	Parameter	Min	Nom	Max	Unit
$V_{DD}$	Supply voltage	2.7		5.5	V
$T_A$	Operating free-air temperature range	0		70	°C

**Figure 8:**  
Electrical Characteristics at  $V_{DD} = 5V$ ,  $T_A = 25^\circ C$ ,  $\lambda_p = 470nm$ ,  $R_L = 10k\Omega$  (unless otherwise noted) <sup>(1) (2)</sup>

Symbol	Parameter	Test Conditions	Min	Typ	Max	Unit
$V_D$	Dark voltage	$E_e = 0$	0		15	mV
$V_{OM}$	Maximum output voltage swing	$V_{DD} = 4.5V$ , No Load		4.49		V
		$V_{DD} = 4.5V$ , $R_L = 10k\Omega$	4	4.2		
$V_O$	Output voltage	$E_e = 1.54\mu W/cm^2$ , $\lambda_p = 470nm$ <sup>(4)</sup>	1.6	2	2.4	V
$\alpha_{VD}$	Temperature coefficient of dark voltage ( $V_D$ )	$T_A = 0^\circ C$ to $70^\circ C$		-15		$\mu V/^\circ C$
$N_e$	Irradiance responsivity	$\lambda_p = 428nm$ <sup>(3), (7)</sup>		1.18		V/ $(\mu W/cm^2)$
		$\lambda_p = 470nm$ <sup>(4), (7)</sup>		1.30		
		$\lambda_p = 565nm$ <sup>(5), (7)</sup>		1.58		
		$\lambda_p = 645nm$ <sup>(6), (7)</sup>		1.68		

Symbol	Parameter	Test Conditions	Min	Typ	Max	Unit
PSRR	Power supply rejection ratio	$f_{ac} = 100\text{Hz}$ <sup>(8)</sup>		55		dB
		$f_{ac} = 1\text{kHz}$ <sup>(8)</sup>		35		dB
$I_{DD}$	Supply current	$E_e = 1.54\mu\text{W}/\text{cm}^2$ , $\lambda_p = 470\text{nm}$ <sup>(4)</sup>		1.9	3.5	mA

**Note(s):**

1. Measured with  $R_L = 10\text{k}\Omega$  between output and ground.
2. Optical measurements are made using small-angle incident radiation from a light-emitting diode (LED) optical source.
3. The input irradiance is supplied by a GaN/SiC light-emitting diode with the following characteristics: peak wavelength  $\lambda_p = 428\text{nm}$ , spectral halfwidth  $\Delta\lambda_{1/2} = 65\text{nm}$ .
4. The input irradiance is supplied by an InGaN light-emitting diode with the following characteristics: peak wavelength  $\lambda_p = 470\text{nm}$ , spectral halfwidth  $\Delta\lambda_{1/2} = 35\text{nm}$ .
5. The input irradiance is supplied by a GaP light-emitting diode with the following characteristics: peak wavelength  $\lambda_p = 565\text{nm}$ , spectral halfwidth  $\Delta\lambda_{1/2} = 28\text{nm}$ .
6. The input irradiance is supplied by an AlGaAs light-emitting diode with the following characteristics: peak wavelength  $\lambda_p = 645\text{nm}$ , spectral halfwidth  $\Delta\lambda_{1/2} = 25\text{nm}$ .
7. Irradiance responsivity is characterized over the range  $V_O = 0.1\text{V}$  to  $4.5\text{V}$ . The best-fit straight line of Output Voltage  $V_O$  versus Irradiance  $E_e$  over this range will typically have a positive extrapolated  $V_O$  value for  $E_e = 0$ .
8. Power supply rejection ratio PSRR is defined as  $20 \log (\Delta V_{DD}(f)/\Delta V_O(f))$  with  $V_{DD}(f = 0) = 5\text{V}$  and  $V_O(f = 0) = 2\text{V}$ .

**Figure 9:**  
**Switching Characteristics at  $V_{DD} = 5V$ ,  $T_A = 25^\circ C$ ,  $\lambda_p = 470nm$ ,  $R_L = 10k\Omega$  (unless otherwise noted)**

Symbol	Parameter	Test Conditions	Min	Typ	Max	Unit
$t_r$	Output pulse rise time, 10% to 90% of final value	See note (1) and Figure 10		160	250	$\mu s$
$t_f$	Output pulse fall time, 10% to 90% of final value	See note (1) and Figure 10		150	250	$\mu s$
$t_s$	Output settling time to 1% of final value	See note (1) and Figure 10		330		$\mu s$
	Integrated noise voltage	$f = dc$ to 1kHz, $E_e = 0$		200		$\mu V_{rms}$
$V_n$	Output noise voltage, rms	$f = 10Hz$ , $E_e = 0$		6		$\frac{\mu V}{\sqrt{Hz}}$ (rms)
		$f = 100Hz$ , $E_e = 0$		6		
		$f = 1kHz$ , $E_e = 0$		7		

**Note(s):**

1. Switching characteristics apply over the range  $V_O = 0.1V$  to 4.5V.

## Parameter Measurement Information

Figure 10:  
Switching Times

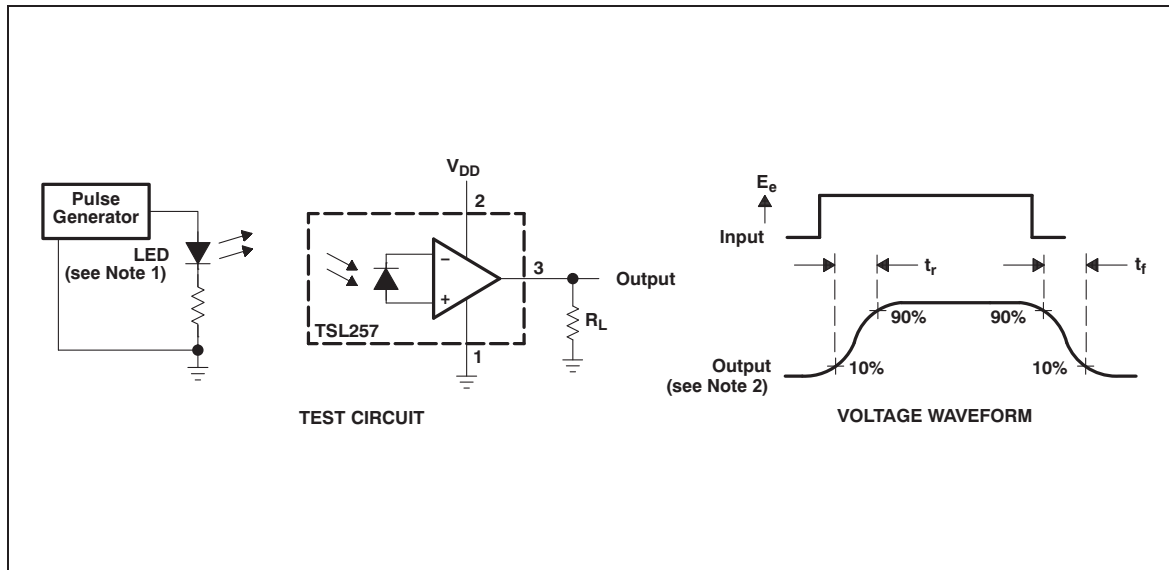

**Note(s):**

1. The input irradiance is supplied by a pulsed InGaN light-emitting diode with the following characteristics:  $\lambda_p = 470\text{nm}$ ,  $t_r < 1\mu\text{s}$ ,  $t_f < 1\mu\text{s}$ .
2. The output waveform is monitored on an oscilloscope with the following characteristics:  $t_r < 100\text{ns}$ ,  $Z_i \geq 1\text{M}\Omega$ ,  $C_i \leq 20\text{pF}$ .



## Typical Operating Characteristics

Figure 11:  
Photodiode Spectral Responsivity

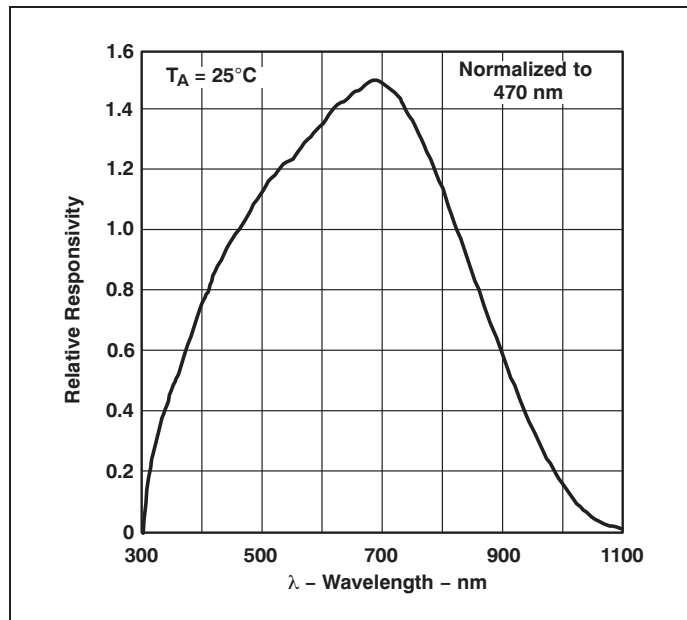
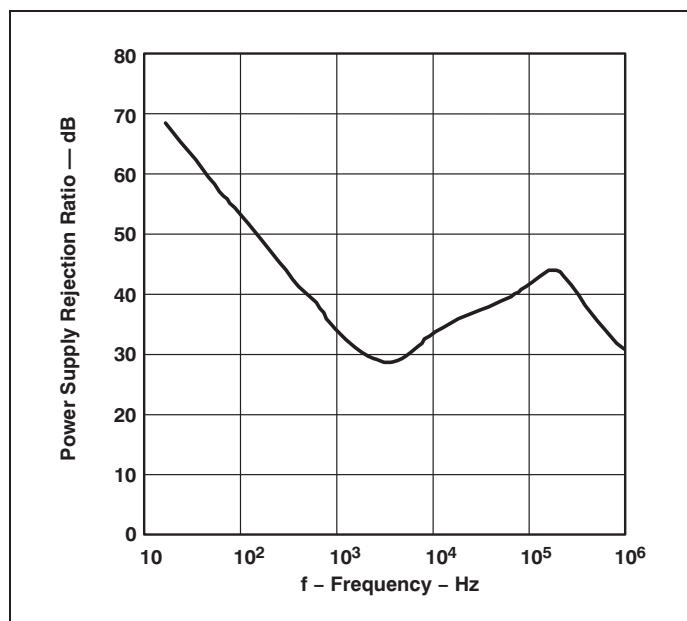
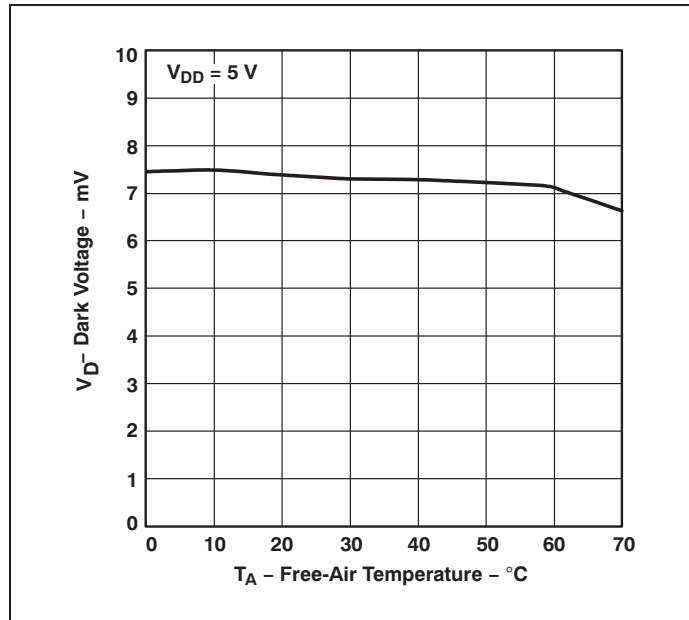

Figure 12:  
Power Supply Rejection Ratio vs. Frequency



**Figure 13:**  
Dark Voltage vs. Free-Air Temperature



**Figure 14:**  
Normalized Response vs. Angular Displacement

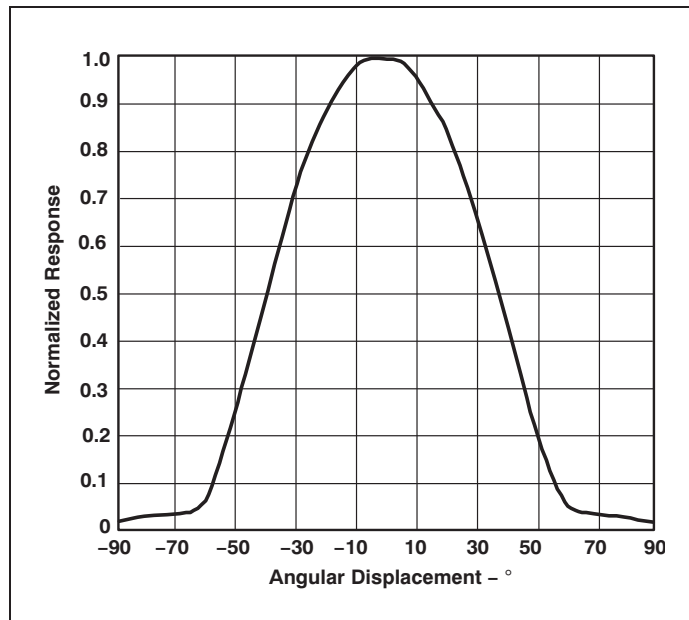

## Application Information

### PCB Pad Layout

Suggested PCB pad layout guidelines for the SM surface mount package are shown in [Figure 15](#).

**Figure 15:**  
**Suggested SM Package PCB Layout**

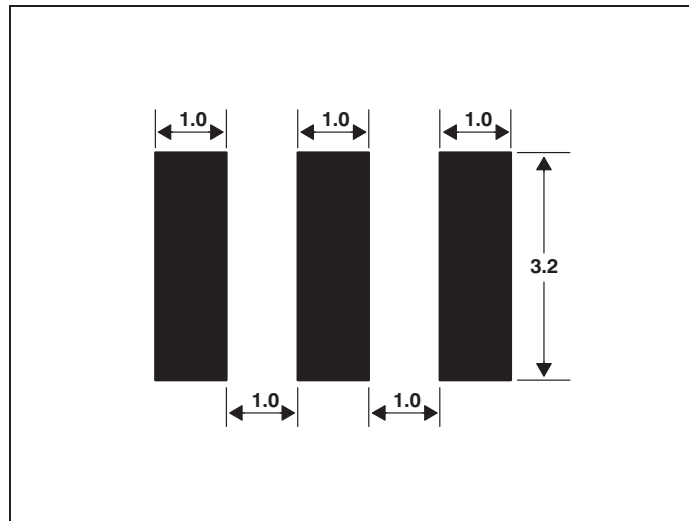

**Note(s):**

1. All linear dimensions are in millimeters.
2. This drawing is subject to change without notice.

**Package Mechanical Data**

The device is supplied in a clear plastic three-lead sidelooker through-hole package (S).

**Plastic Single-In-Line Side-Looker Package**

**Figure 16:**  
Package S - Plastic Single-In-Line Side-Looker Package Configuration

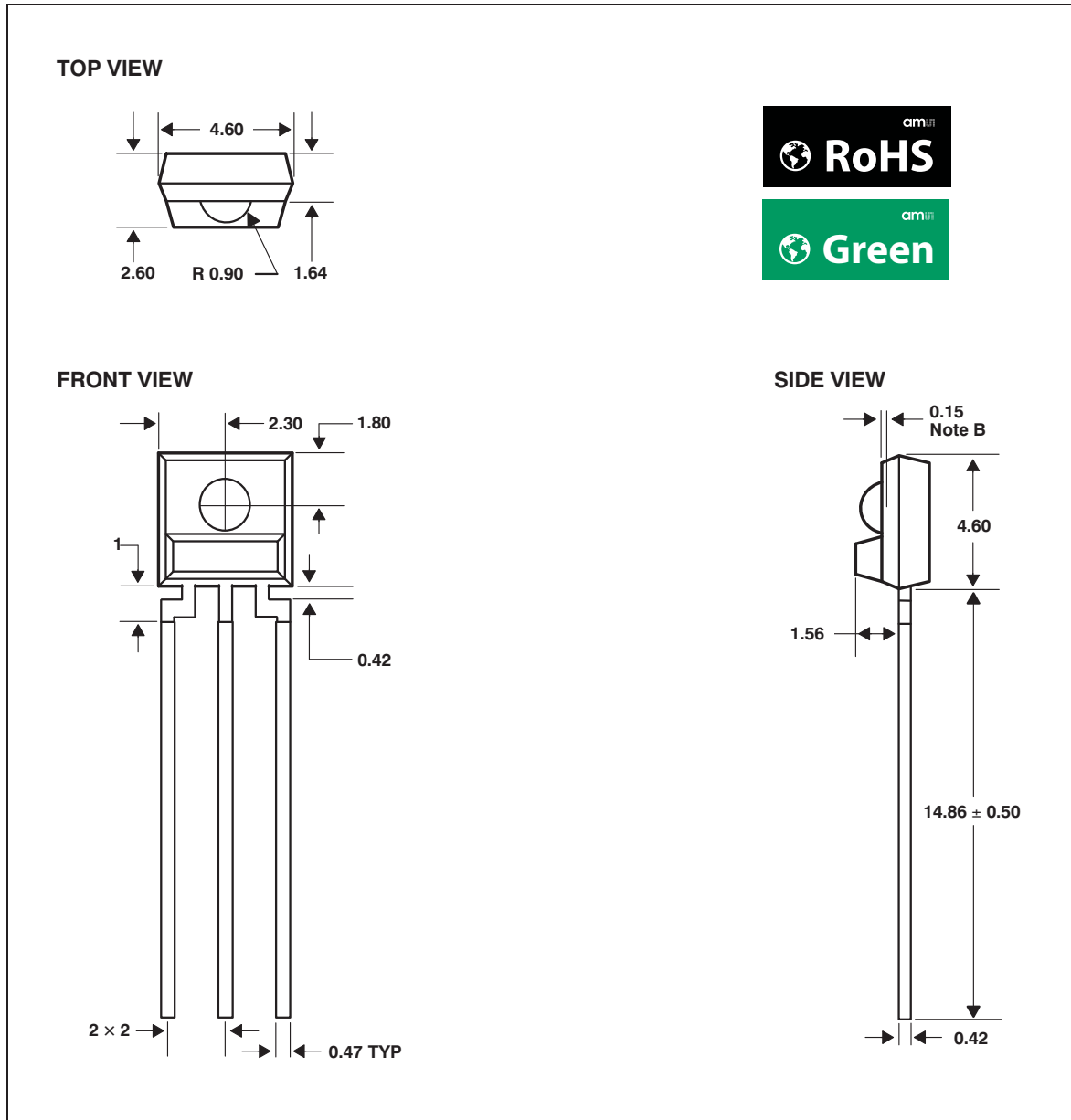

**Note(s):**

1. All linear dimensions are in millimeters; tolerance is  $\pm 0.25\text{mm}$  unless otherwise stated.
2. Dimension is to center of lens arc, which is located below the package face.
3. The integrated photodiode active area is round with a typical diameter of 0.75mm and is typically located in the center of the lens and 0.97mm below the top of the lens surface.
4. Index of refraction of clear plastic is 1.55.
5. Lead finish for TSL257-LF: solder dipped, 100% Sn.
6. This drawing is subject to change without notice.

## Plastic Surface Mount Side-Looker Package

Figure 17:  
Package SM - Plastic Surface Mount Side-Looker Package Configuration

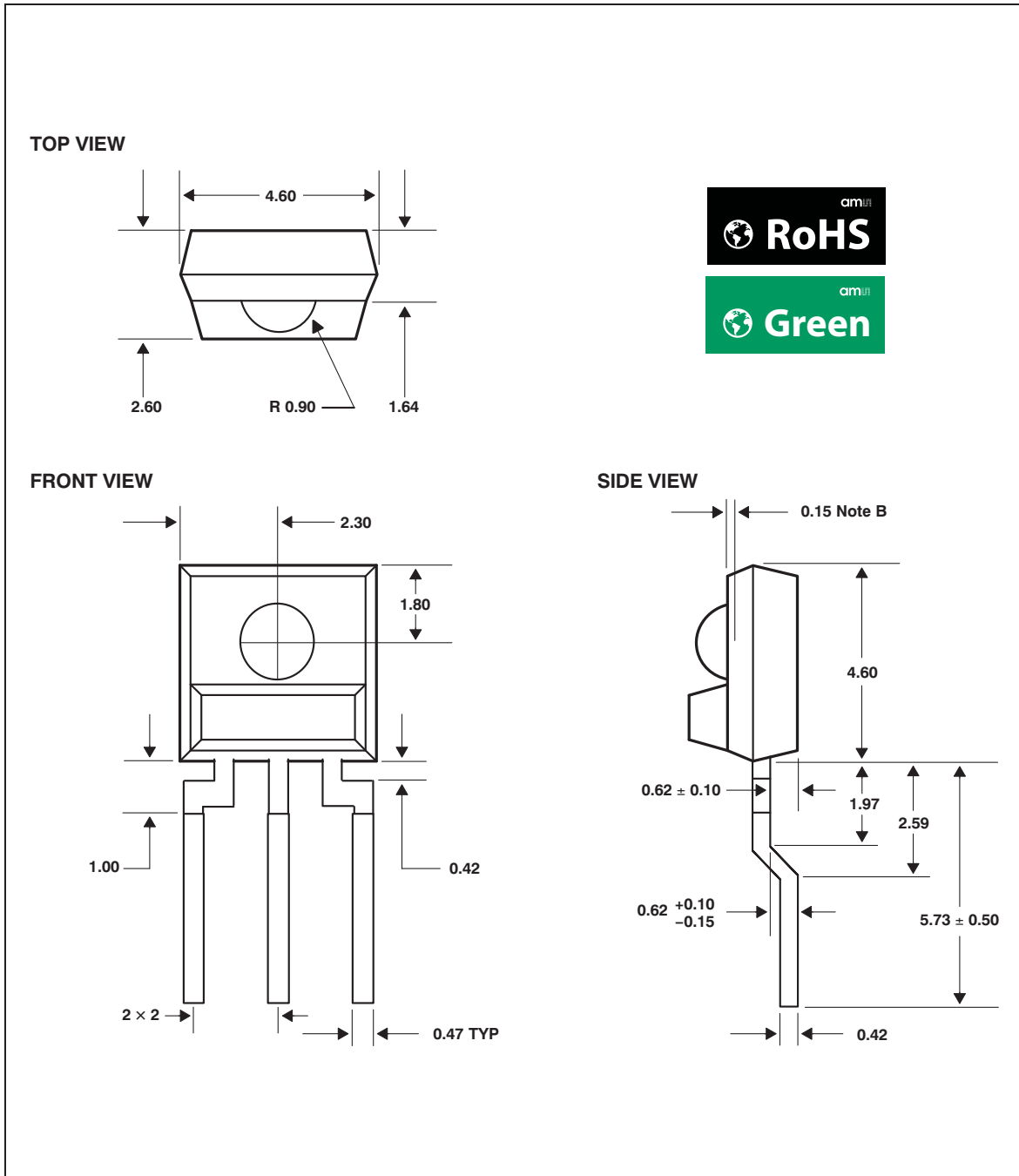

**Note(s):**

1. All linear dimensions are in millimeters; tolerance is  $\pm 0.25\text{mm}$  unless otherwise stated.
2. Dimension is to center of lens arc, which is located below the package face.
3. The integrated photodiode active area is typically located in the center of the lens and  $0.97\text{mm}$  below the top of the lens surface.
4. Index of refraction of clear plastic is 1.55.
5. Lead finish for TSL257SM-LF: solder dipped, 100% Sn.
6. This drawing is subject to change without notice.

## Ordering & Contact Information

Figure 18:  
Ordering Information

Ordering Code	Device	T <sub>A</sub>	Package-Leads	Package Designator
TSL257-LF	TSL257	0°C to 70°C	3-lead Sidelooker - Lead (Pb) Free	S
TSL257SM-LF	TSL257	0°C to 70°C	3-lead Surface-Mount Sidelooker - Lead (Pb) Free	SM

Buy our products or get free samples online at:

[www.ams.com/ICdirect](http://www.ams.com/ICdirect)

Technical Support is available at:

[www.ams.com/Technical-Support](http://www.ams.com/Technical-Support)

Provide feedback about this document at:

[www.ams.com/Document-Feedback](http://www.ams.com/Document-Feedback)

For further information and requests, e-mail us at:

[ams\\_sales@ams.com](mailto:ams_sales@ams.com)

For sales offices, distributors and representatives, please visit:

[www.ams.com/contact](http://www.ams.com/contact)

### Headquarters

ams AG  
Tobelbader Strasse 30  
8141 Premstaetten  
Austria, Europe

Tel: +43 (0) 3136 500 0

Website: [www.ams.com](http://www.ams.com)

## RoHS Compliant & ams Green Statement

**RoHS:** The term RoHS compliant means that ams AG products fully comply with current RoHS directives. Our semiconductor products do not contain any chemicals for all 6 substance categories, including the requirement that lead not exceed 0.1% by weight in homogeneous materials. Where designed to be soldered at high temperatures, RoHS compliant products are suitable for use in specified lead-free processes.

**ams Green (RoHS compliant and no Sb/Br):** ams Green defines that in addition to RoHS compliance, our products are free of Bromine (Br) and Antimony (Sb) based flame retardants (Br or Sb do not exceed 0.1% by weight in homogeneous material).

**Important Information:** The information provided in this statement represents ams AG knowledge and belief as of the date that it is provided. ams AG bases its knowledge and belief on information provided by third parties, and makes no representation or warranty as to the accuracy of such information. Efforts are underway to better integrate information from third parties. ams AG has taken and continues to take reasonable steps to provide representative and accurate information but may not have conducted destructive testing or chemical analysis on incoming materials and chemicals. ams AG and ams AG suppliers consider certain information to be proprietary, and thus CAS numbers and other limited information may not be available for release.

## Copyrights & Disclaimer

Copyright ams AG, Tobelbader Strasse 30, 8141 Premstaetten, Austria-Europe. Trademarks Registered. All rights reserved. The material herein may not be reproduced, adapted, merged, translated, stored, or used without the prior written consent of the copyright owner.

Devices sold by ams AG are covered by the warranty and patent indemnification provisions appearing in its General Terms of Trade. ams AG makes no warranty, express, statutory, implied, or by description regarding the information set forth herein. ams AG reserves the right to change specifications and prices at any time and without notice. Therefore, prior to designing this product into a system, it is necessary to check with ams AG for current information. This product is intended for use in commercial applications. Applications requiring extended temperature range, unusual environmental requirements, or high reliability applications, such as military, medical life-support or life-sustaining equipment are specifically not recommended without additional processing by ams AG for each application. This product is provided by ams AG "AS IS" and any express or implied warranties, including, but not limited to the implied warranties of merchantability and fitness for a particular purpose are disclaimed.

ams AG shall not be liable to recipient or any third party for any damages, including but not limited to personal injury, property damage, loss of profits, loss of use, interruption of business or indirect, special, incidental or consequential damages, of any kind, in connection with or arising out of the furnishing, performance or use of the technical data herein. No obligation or liability to recipient or any third party shall arise or flow out of ams AG rendering of technical or other services.



## Document Status

Document Status	Product Status	Definition
Product Preview	Pre-Development	Information in this datasheet is based on product ideas in the planning phase of development. All specifications are design goals without any warranty and are subject to change without notice
Preliminary Datasheet	Pre-Production	Information in this datasheet is based on products in the design, validation or qualification phase of development. The performance and parameters shown in this document are preliminary without any warranty and are subject to change without notice
Datasheet	Production	Information in this datasheet is based on products in ramp-up to full production or full production which conform to specifications in accordance with the terms of ams AG standard warranty as given in the General Terms of Trade
Datasheet (discontinued)	Discontinued	Information in this datasheet is based on products which conform to specifications in accordance with the terms of ams AG standard warranty as given in the General Terms of Trade, but these products have been superseded and should not be used for new designs

## Revision Information

Changes from 023E (2007-Sep) to current revision 1-00 (2016-Jul-25)	Page
Content of TAOS datasheet was converted to the latest <b>ams</b> design	
Added Figure 1	1
Updated note under Figure 16	12
Updated Figure 18	14

**Note(s):**

1. Page and figure numbers for the previous version may differ from page and figure numbers in the current revision.
2. Correction of typographical errors is not explicitly mentioned.

## Content Guide

- 1 General Description**
  - 1 Key Benefits & Features
  - 2 Functional Block Diagram
  
- 3 Pin Assignment**
- 4 Absolute Maximum Ratings**
  
- 5 Electrical Characteristics**
  - 5 Operating Conditions
  
- 8 Parameter Measurement Information**
- 9 Typical Operating Characteristics**
  
- 11 Application Information**
  - 11 PCB Pad Layout
  
- 12 Package Mechanical Data**
  - 12 Plastic Single-In-Line Side-Looker Package
  - 13 Plastic Surface Mount Side-Looker Package
  
- 14 Ordering & Contact Information**
- 15 RoHS Compliant & ams Green Statement**
- 16 Copyrights & Disclaimer**
- 17 Document Status**
- 18 Revision Information**