

100V Half-Bridge MOSFET Driver with Anti-Shoot-Through Protection

Features

- Drives High- and Low-Side N-Channel MOSFETs with Single Input
- Adaptive Anti-Shoot-Through Protection
- Low-Side Drive Disable Pin
- Bootstrap Supply Voltage to 118V DC
- Supply Voltage up to 16V
- TTL Input Thresholds
- On-Chip Bootstrap Diode
- Fast 30 ns Propagation Times
- Drives 1000 pF Load with 10 ns Rise and Fall Times
- Low Power Consumption
- Supply Undervoltage Protection
- 2.5Ω Pull-Up, 1.5Ω Pull-Down Output Resistance
- Space Saving SOIC-8L Package
- -40°C to +125°C Junction Temperature Range

Applications

- High Voltage Buck Converters
- Networking/Telecom Power Supplies
- Automotive Power Supplies
- Current-Fed Push-Pull Power Topologies
- Ultrasonic Drivers
- Avionic Power Supplies

General Description

The MIC4102 is a high frequency, 100V half-bridge MOSFET driver IC featuring internal anti-shoot-through protection. The low-side and high-side gate drivers are controlled by a single input signal to the PWM pin. The MIC4102 implements adaptive anti-shoot-through circuitry to optimize the switching transitions for maximum efficiency. The single input control also reduces system complexity and greatly simplifies the overall design.

The MIC4102 also features a low-side drive disable pin. This gives the MIC4102 the capability to operate in a non-synchronous buck mode. This feature allows the MIC4102 to start up into applications where a bias voltage may already be present without pulling the output voltage down.

Undervoltage protection on both the low-side and high-side supplies forces the outputs low. An on-chip bootstrap diode eliminates the discrete diode required with other driver ICs.

The MIC4102 is available in the SOIC-8L package with a junction operating range from -40°C to +125°C.

Typical Application Schematic

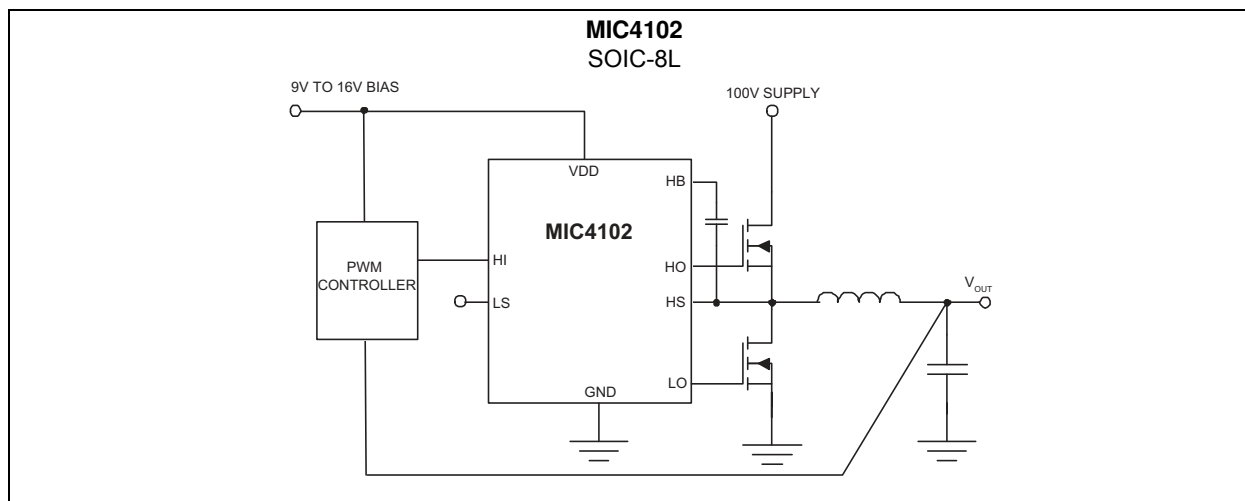

MIC4102

Functional Block Diagram

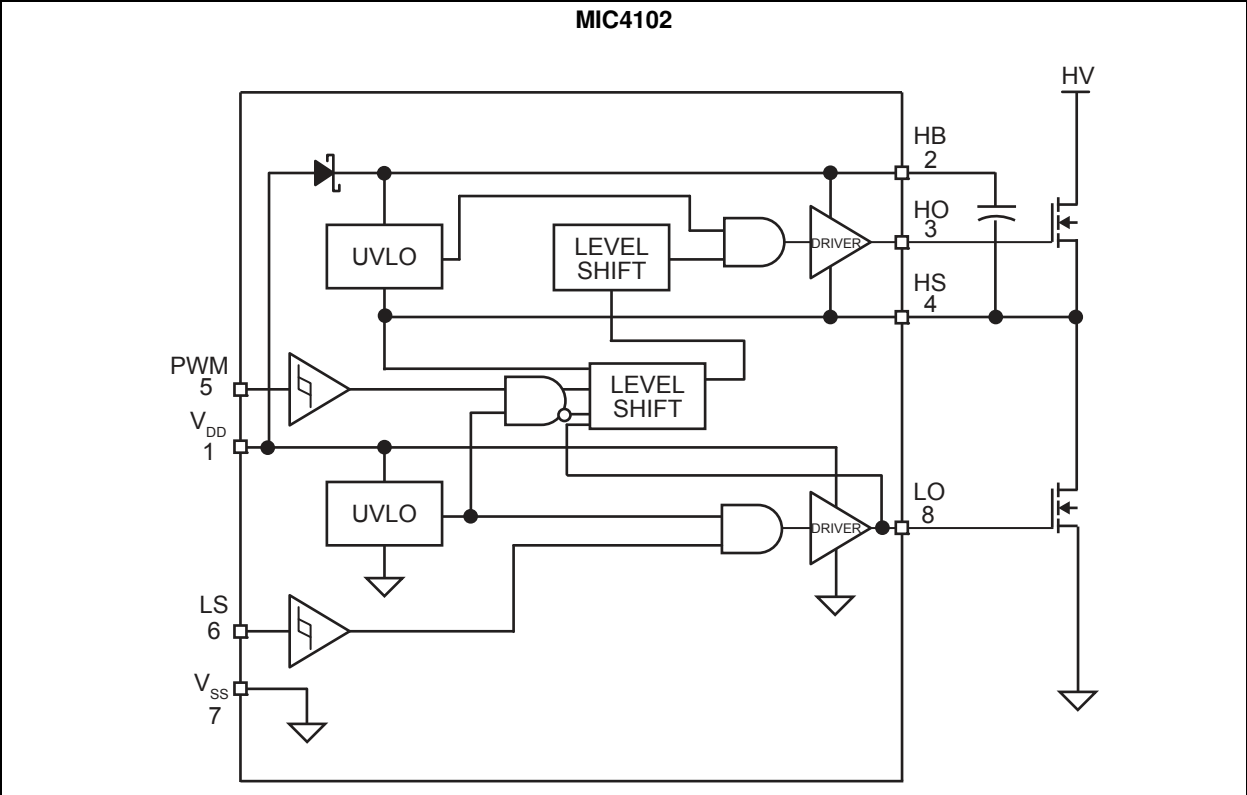

1.0 ELECTRICAL CHARACTERISTICS

Absolute Maximum Ratings †

Supply Voltage (V_{DD} , $V_{HB} - V_{HS}$)	-0.3V to +18V
Input Voltages (V_{PWM} , V_{LS}).....	-0.3V to $V_{DD} + 0.3V$
Voltage on LO (V_{LO}).....	-0.3V to $V_{DD} + 0.3V$
Voltage on HO (V_{HO}).....	$V_{HS} - 0.3V$ to $V_{HB} + 0.3V$
Voltage on HS (Continuous).....	-1V to +110V
Voltage on HB	+118V
Average Current in V_{DD} to HB Diode	100 mA
ESD Rating	Note 1

Operating Ratings ‡

Supply Voltage (V_{DD})	+9V to +16V
Voltage on HS	-1V to +100V
Voltage on HS (Repetitive Transient).....	-5V to +105V
HS Slew Rate	50 V/ns
Voltage on HB	$V_{HS} + 8V$ to $V_{HS} + 16V$
and	$V_{DD} - 1V$ to $V_{DD} + 100V$

† **Notice:** Stresses above those listed under “Absolute Maximum Ratings” may cause permanent damage to the device. This is a stress rating only and functional operation of the device at those or any other conditions above those indicated in the operational sections of this specification is not intended. Exposure to maximum rating conditions for extended periods may affect device reliability.

‡ **Notice:** The device is not guaranteed to function outside its operating ratings.

Note 1: Devices are ESD sensitive. Handling precautions are recommended. Human body model, 1.5 k Ω in series with 100 pF.

MIC4102

TABLE 1-1: ELECTRICAL CHARACTERISTICS

Electrical Characteristics: $V_{DD} = V_{HB} = 12V$; $V_{SS} = V_{HS} = 0V$; No load on LO or HO; $T_A = +25^\circ C$; unless noted. Bold values are valid for $-40^\circ C \leq T_J \leq +125^\circ C$. (Note 1).						
Parameters	Sym.	Min.	Typ.	Max.	Units	Conditions
Supply Current						
V_{DD} Quiescent Current	I_{DD}	—	150	450	μA	PWM = 0V
		—	—	600		
V_{DD} Operating Current	I_{DDO}	—	3	3.5	mA	f = 500 kHz
		—	—	4.0		
Total HB Quiescent Current	I_{HB}	—	25	150	μA	PWM = 0V
		—	—	200		
Total HB Operating Current	I_{HBO}	—	1.5	2.5	mA	f = 500 kHz
		—	—	3		
HB to V_{SS} Quiescent Current	I_{HBS}	—	0.05	1	μA	$V_{HS} = V_{HB} = 110V$
		—	—	30		
Input Pins (TTL)						
Low Level Input Voltage Threshold	V_{IL}	0.8	1.5	—	V	—
High Level Input Voltage Threshold	V_{IH}	—	1.5	2.2	V	—
Input Pull-Down Resistance	R_I	100	200	500	k Ω	—
Undervoltage Protection						
V_{DD} Rising Threshold	V_{DDR}	6.5	7.3	8.0	V	—
V_{DD} Threshold Hysteresis	V_{DDH}	—	0.5	—	V	—
HB Rising Threshold	V_{HBR}	6.0	7.0	8.0	V	—
HB Threshold Hysteresis	V_{HBH}	—	0.4	—	V	—
Bootstrap Diode						
Low-Current Forward Voltage	V_{DL}	—	0.4	0.55	V	$I_{VDD-HB} = 100 \mu A$
		—	—	0.70		
High-Current Forward Voltage	V_{DH}	—	0.7	0.8	V	$I_{VDD-HB} = 100 mA$
		—	—	1.0		
Dynamic Resistance	R_D	—	1.0	1.5	Ω	$I_{VDD-HB} = 100 mA$
		—	—	2.0		
LO Gate Driver						
Low Level Output Voltage	V_{OLL}	—	0.18	0.3	V	$I_{LO} = 160 mA$
		—	—	0.4		
High Level Output Voltage	V_{OHL}	—	0.25	0.3	V	$I_{LO} = -100 mA$, $V_{OHL} = V_{DD} - V_{LO}$
		—	—	0.45		
Peak Sink Current	I_{OHL}	—	3	—	A	$V_{LO} = 0V$
Peak Source Current	I_{OLL}	—	2	—	A	$V_{LO} = 12V$

Note 1: Specification for packaged product only.

2: All voltages relative to Pin 7, V_{SS} , unless otherwise specified.

3: Guaranteed by design. Not production tested.

TABLE 1-1: ELECTRICAL CHARACTERISTICS (CONTINUED)

Electrical Characteristics: $V_{DD} = V_{HB} = 12V$; $V_{SS} = V_{HS} = 0V$; No load on LO or HO; $T_A = +25^\circ C$; unless noted. Bold values are valid for $-40^\circ C \leq T_J \leq +125^\circ C$. (Note 1).						
Parameters	Sym.	Min.	Typ.	Max.	Units	Conditions
HO Gate Driver						
Low Level Output Voltage	V_{OLH}	—	0.22	0.3	V	$I_{HO} = 160 \text{ mA}$
		—	—	0.4		
High Level Output Voltage	V_{OHH}	—	0.25	0.3	V	$I_{HO} = -100 \text{ mA}$, $V_{OHH} = V_{HB} - V_{HO}$
		—	—	0.45		
Peak Sink Current	I_{OHH}	—	3	—	A	$V_{HO} = 0V$
Peak Source Current	I_{OLH}	—	2	—	A	$V_{HO} = 12V$
Switching Specifications (Anti-Shoot-Through Circuitry)						
Delay between PWM going high to LO going low	t_{LOOFF}	—	30	45	ns	—
		—	—	60		
Voltage threshold for LO MOSFET to be considered OFF	V_{LOOFF}	—	1.7	—	V	—
Delay between LO OFF to HO going High	t_{HOON}	—	30	50	ns	—
		—	—	60		
Delay between PWM going Low to HO going low	t_{HOOFF}	—	45	65	ns	—
		—	—	70		
Switch Node Voltage Threshold when HO turns off	V_{SWth}	1	2.5	4	V	—
Delay between HO MOSFET being considered off to LO turning ON	t_{LOON}	—	30	60	ns	—
		—	—	70		
Delay between LS going low and LO turning OFF	t_{LSOFF}	—	36	45	ns	$C_L = 1000 \text{ pF}$
		—	—	70		
Forced LO ON, if V_{LOTH} is not detected	t_{SWTO}	120	250	450	ns	—
Switching Specifications						
Either Output Rise Time (3V to 9V)	t_R	—	10	—	ns	$C_L = 1000 \text{ pF}$
Either Output Fall Time (3V to 9V)	t_F	—	6	—	ns	$C_L = 1000 \text{ pF}$
Either Output Rise Time (3V to 9V)	t_R	—	0.33	0.6	μs	$C_L = 0.1 \text{ }\mu F$
		—	—	0.8		
Either Output Fall Time (3V to 9V)	t_F	—	0.2	0.3	μs	$C_L = 0.1 \text{ }\mu F$
		—	—	0.4		
Minimum Input Pulse Width that changes the output with LS = 5V	t_{PW}	—	40	60	ns	$C_L = 0$, Note 3
Minimum Output Pulse Width on HO with min pulse width on PWM with LS = 5V	t_{PW}	—	15	—	ns	$C_L = 0$, Note 3

Note 1: Specification for packaged product only.

2: All voltages relative to Pin 7, V_{SS} , unless otherwise specified.

3: Guaranteed by design. Not production tested.

MIC4102

TABLE 1-1: ELECTRICAL CHARACTERISTICS (CONTINUED)

Electrical Characteristics: $V_{DD} = V_{HB} = 12V$; $V_{SS} = V_{HS} = 0V$; No load on LO or HO; $T_A = +25^\circ C$; unless noted. Bold values are valid for $-40^\circ C \leq T_J \leq +125^\circ C$. (Note 1).						
Parameters	Sym.	Min.	Typ.	Max.	Units	Conditions
Minimum Input Pulse Width that changes the output with LS = 0V	t_{PW}	—	13	20	ns	$C_L = 0$, Note 3
Minimum Output Pulse Width on HO with min pulse width on PWM with LS = 0V	—	—	20	—	—	$C_L = 0$, Note 3
Bootstrap Diode Turn-On or Turn-Off Time	t_{BS}	—	10	—	ns	—

- Note 1:** Specification for packaged product only.
2: All voltages relative to Pin 7, V_{SS} , unless otherwise specified.
3: Guaranteed by design. Not production tested.

TEMPERATURE SPECIFICATIONS

Parameters	Sym.	Min.	Typ.	Max.	Units	Conditions
Temperature Ranges						
Max. Junction Temperature Range	T_J	-55	—	+150	°C	Note 1
Storage Temperature Range	T_S	-60	—	+150	°C	—
Operating Junction Temperature Range	T_J	-40	—	+125	°C	—
Package Thermal Resistances						
Thermal Resistance, SOIC-8L	θ_{JA}	—	140	—	°C/W	—

Note 1: The maximum allowable power dissipation is a function of ambient temperature, the maximum allowable junction temperature and the thermal resistance from junction to air (i.e., T_A , T_J , θ_{JA}). Exceeding the maximum allowable power dissipation will cause the device operating junction temperature to exceed the maximum +125°C rating. Sustained junction temperatures above +125°C can impact the device reliability.

MIC4102

2.0 TYPICAL PERFORMANCE CURVES

Note: The graphs and tables provided following this note are a statistical summary based on a limited number of samples and are provided for informational purposes only. The performance characteristics listed herein are not tested or guaranteed. In some graphs or tables, the data presented may be outside the specified operating range (e.g., outside specified power supply range) and therefore outside the warranted range.

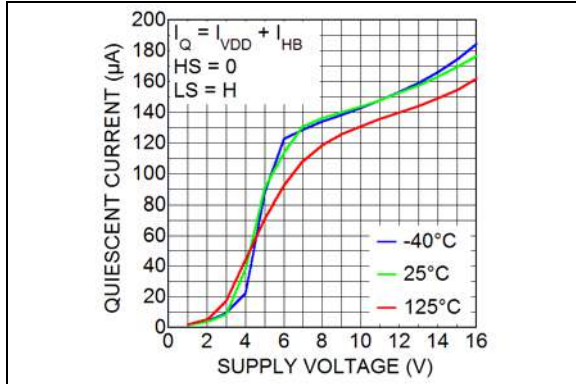

FIGURE 2-1: Quiescent Current vs. Supply Voltage.

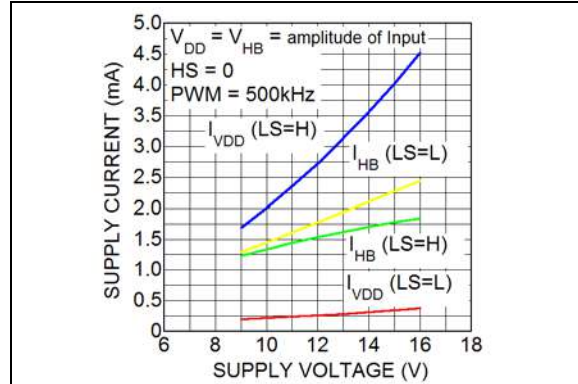

FIGURE 2-4: Supply Current vs. Supply Voltage vs. LS Level.

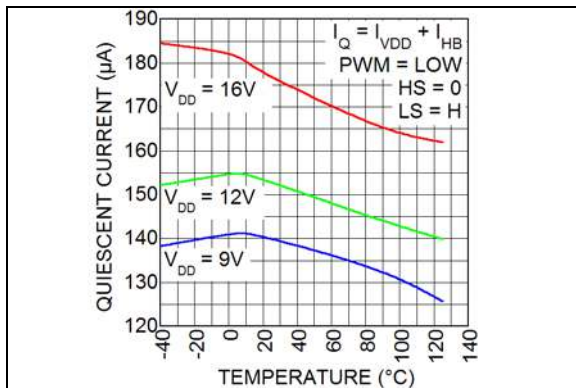

FIGURE 2-2: Quiescent Current vs. Temperature.

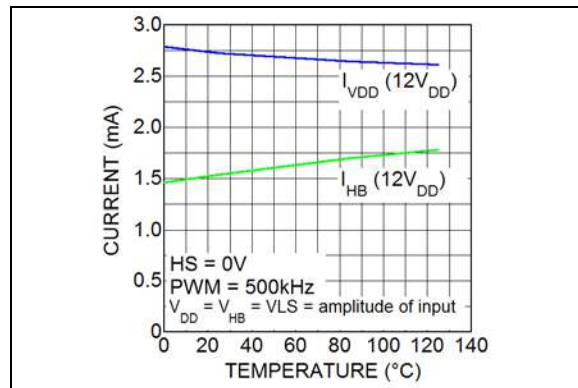

FIGURE 2-5: Operating Current vs. Temperature.

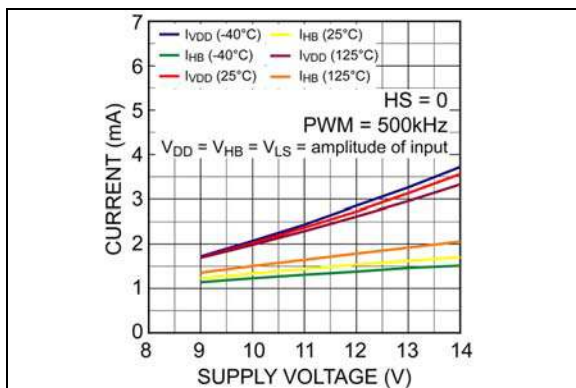

FIGURE 2-3: Operating Current vs. Supply Voltage.

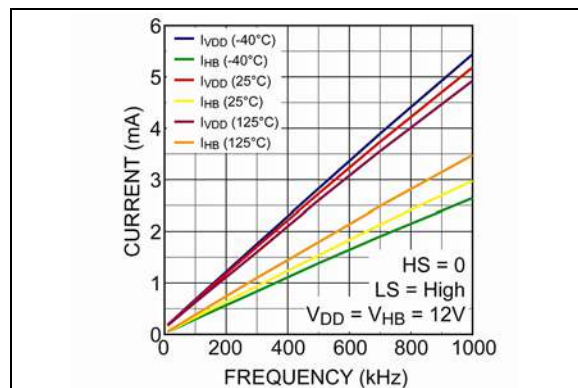

FIGURE 2-6: Supply Current vs. Frequency.

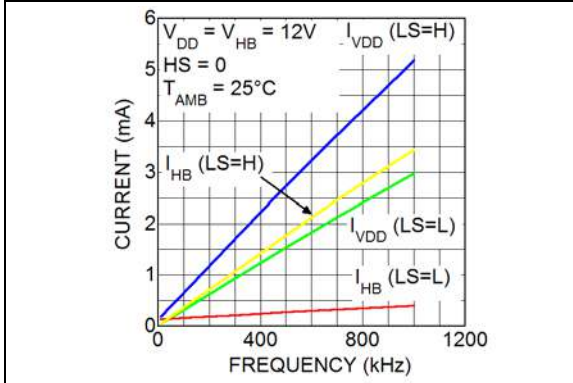

FIGURE 2-7: Supply Current vs. Frequency for Pin L and H.

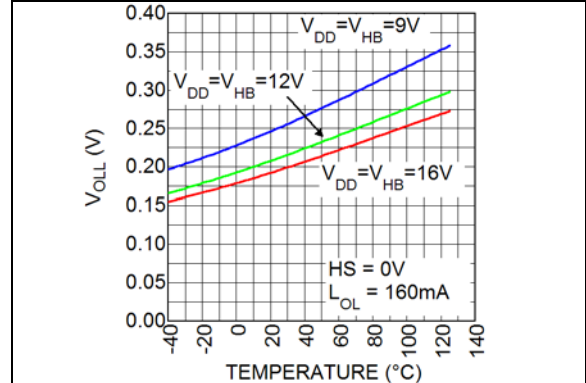

FIGURE 2-10: Low Level Output of Low-Side Driver vs. Temperature.

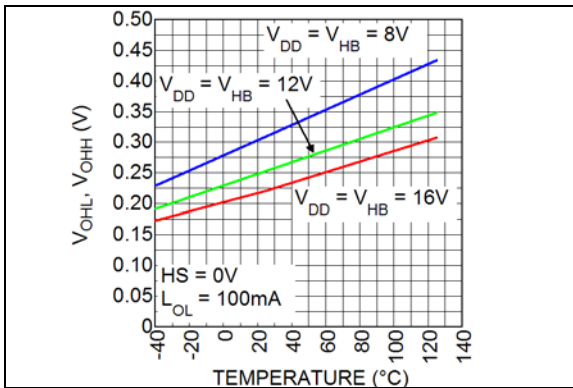

FIGURE 2-8: High Level Output Voltage vs. Temperature.

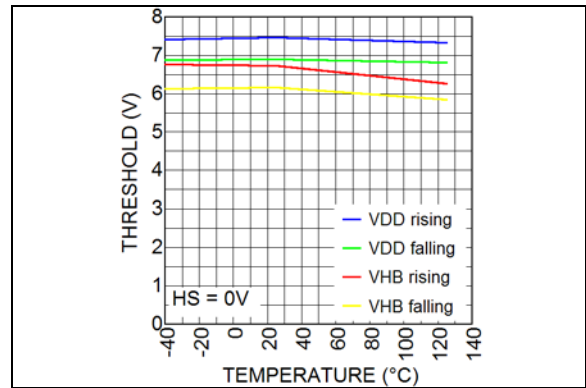

FIGURE 2-11: UVLO Thresholds vs. Temperature.

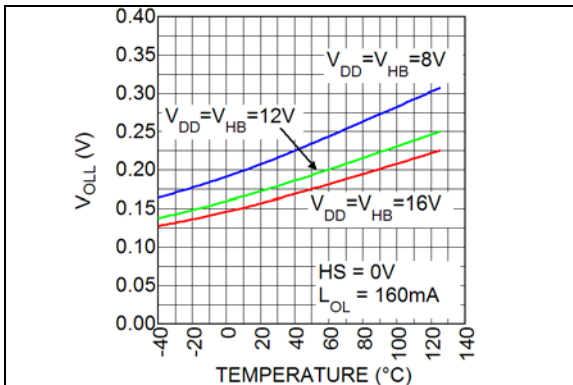

FIGURE 2-9: Low Level Output of Low-Side Driver vs. Temperature.

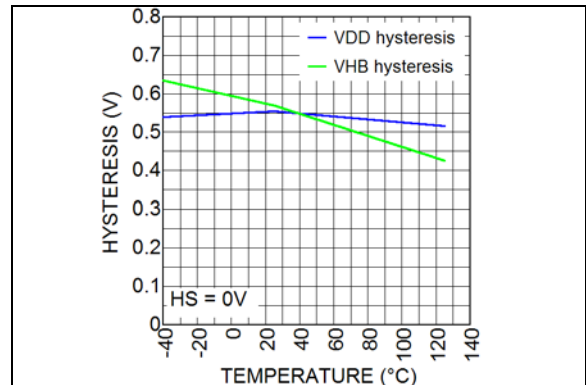

FIGURE 2-12: UVLO Hysteresis vs. Temperature.

MIC4102

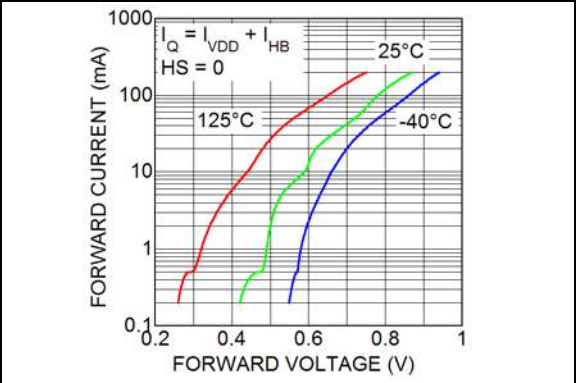

FIGURE 2-13: Bootstrap Diode I-V Characteristics.

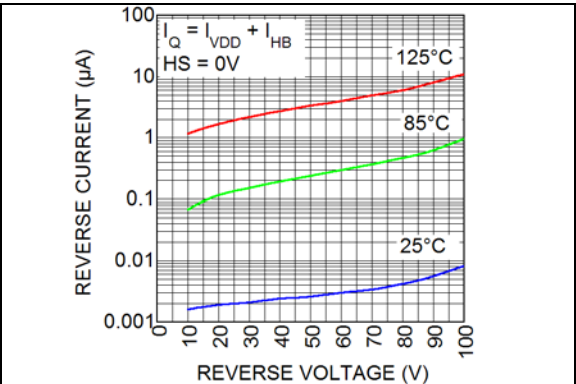

FIGURE 2-14: Bootstrap Diode Reverse Current.

3.0 PIN DESCRIPTIONS

The descriptions of the pins are listed in [Table 3-1](#).

Package Type

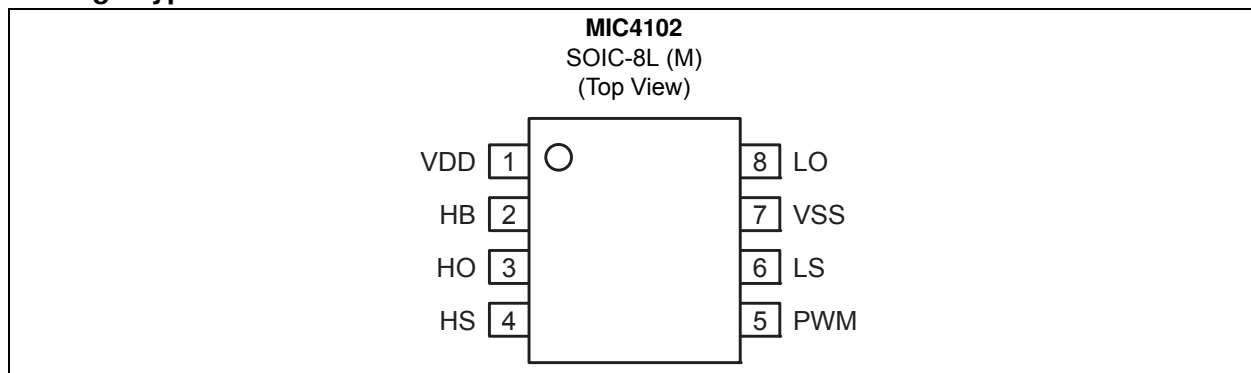

TABLE 3-1: PIN FUNCTION TABLE

Pin Number	Pin Name	Description
1	V _{DD}	Positive supply to lower gate drivers. Decouple this pin to V _{SS} (Pin 7). Bootstrap diode connected to HB (Pin 2).
2	HB	High-Side Bootstrap supply. External bootstrap capacitor is required. Connect positive side of bootstrap capacitor to this pin. Bootstrap diode is on-chip.
3	HO	High-Side Output. Connect to gate of high-side power MOSFET.
4	HS	High-Side Source connection. Connect to source of high-side power MOSFET. Connect negative side of bootstrap capacitor to this pin.
5	PWM	Control Input. PWM high signal makes high-side HO output high and low-side LO output low. PWM low signal makes high-side HO output low and low-side LO output high.
6	LS	Low-Side Disable. When pulled low, this control signal immediately terminates the low-side LO output drive. The low-side LO output drive will remain low until this signal is removed. HS drive is not affected by the LS signal. The logic table is below (see Table 3-2).
7	V _{SS}	Chip negative supply. Generally, this will be grounded.
8	LO	Low-Side Output. Connect to gate of low-side power MOSFET.

TABLE 3-2: LS PIN LOGIC TABLE

LS	PWM	LO	HO
0	0	0	0
0	1	0	1
1	0	1	0
1	1	0	1

MIC4102

4.0 TIMING DIAGRAM

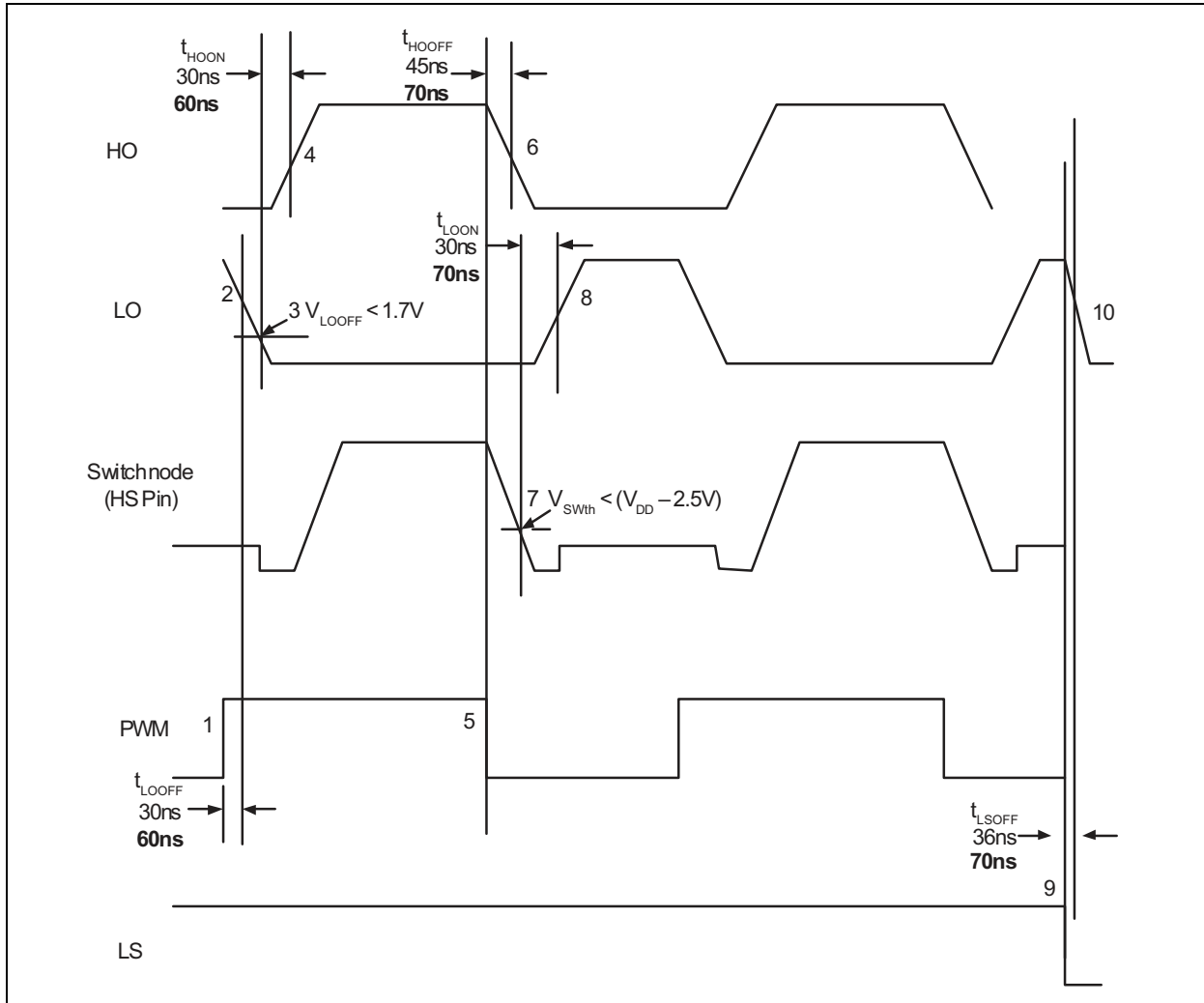

FIGURE 4-1: MIC4102 Timing Diagram.

TABLE 4-1: TIME POINTS AND ACTIONS FOR [Figure 4-1](#)

Time Point	Action
1-2	PWM signal goes high. This initiates the LO signal to go low. The delay between PWM high to $(V_{LO} - 10\%)$ is typically 30 ns (t_{LOFF}).
2-4	LO goes low. When LO reaches 1.7V (V_{LOOFF}) the low-side MOSFET is deemed to be off. The high-side output HO then goes high. The delay between 3 and 4 is typically 30 ns (T_{HOON}); this allows for large turn off delay times of MOSFETs.
5-7	PWM goes low; HO goes low, typically within 45 ns, t_{HOOF} . The switch node (HS pin) is then monitored; when the switch node is $V_{DD} - 2.5\text{V}$ (V_{SWTH}) the high-side MOSFET is deemed to be off and the LO output goes high within typically 30 ns (t_{LOON}). This is controlled by a one shot and remains high until PWM goes high. This is because it is possible to have the SW node oscillate, and could easily bounce through 10V level. If the LO high transition has not happened within 250 ns, it is forced to happen, unless the LS input is low.
8-10	If at any time after 7 has occurred and LS pin goes low, the LO output will turn off within 36 ns (V_{LSOFF}). HO will remain off. The LS pin overrides all shoot-through control logic. If LS is low at the start of the next cycle when PWM signal goes high then HO shall switch transition 1-4 as normal. (i.e. PWM signal equals HO output, LO = 0V).

5.0 FUNCTIONAL DESCRIPTION

The MIC4102 is a high voltage, non-inverting, synchronous MOSFET driver that uses a single PWM input signal to alternately drive both high-side and low-side N-Channel MOSFETs. The [Functional Block Diagram](#) of the MIC4102 is shown on page two.

The MIC4102 input is TTL-compatible. The high-side output buffer includes a high speed level-shifting circuit that is referenced to the HS pin. An internal diode is used as part of a bootstrap circuit to provide the drive voltage for the high-side output.

5.1 Startup and UVLO

The UVLO circuit forces both driver outputs low until the supply voltage exceeds the UVLO threshold. The low-side UVLO circuit monitors the voltage between the V_{DD} and V_{SS} pins. The high-side UVLO circuit monitors the voltage between the HB and HS pins. Hysteresis in the UVLO circuit prevents noise and finite circuit impedance from causing chatter during turn-on.

The V_{DD} pin voltage is supplied to the HS pin through the internal bootstrap diode. The HB pin voltage will always be a diode drop less than V_{DD} .

5.2 Input Stage

The MIC4102 utilizes a TTL-compatible input stage. The PWM input pin is referenced to the V_{SS} pin. The voltage state of the input signal does not change the quiescent current draw of the driver. The threshold level is independent of the V_{DD} supply voltage and there is no dependence between I_{VDD} and the input signal amplitude. This feature makes the MIC4102 an excellent level translator that will drive high threshold MOSFETs from a low voltage PWM IC.

5.3 Low-Side Driver

A block diagram of the low-side driver is shown in [Figure 5-1](#). The low-side driver is designed to drive a ground (V_{SS} pin) referenced N-channel MOSFET. Low driver impedances allow the external MOSFET to be turned on and off quickly. The rail-to-rail drive capability of the output ensures a low $R_{DS(ON)}$ from the external MOSFET.

A low level applied to PWM pin will cause the HO output to go low and the LO output to go high. The upper driver FET turns on and V_{DD} is applied to the gate of the external MOSFET. A high level on the PWM pin forces the LO output low by turning off the upper driver and turning on the lower driver which ground the gate of the external MOSFET.

Pulling the LS pin low disables the LO pin.

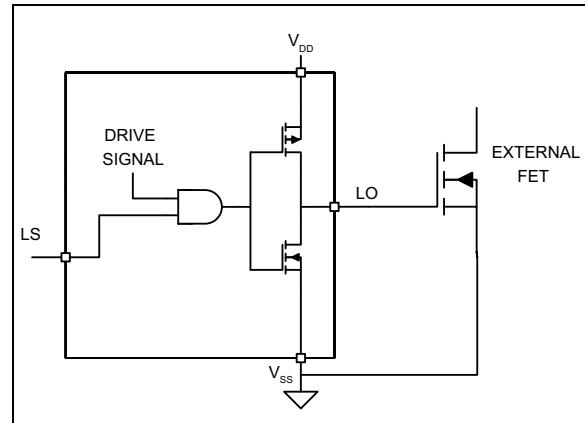

FIGURE 5-1: Low-Side Driver Block Diagram.

5.4 High-Side Driver and Bootstrap Circuit

A block diagram of the high-side driver and bootstrap circuit is shown in [Figure 5-2](#). This driver is designed to drive a floating N-channel MOSFET, whose source terminal is referenced to the HS pin.

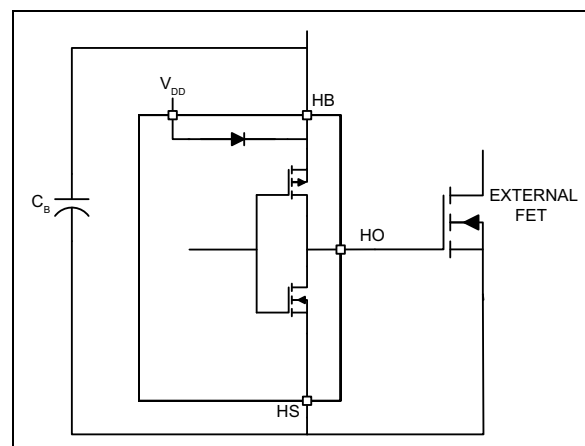

FIGURE 5-2: High-Side Driver Block Diagram.

A low-power, high-speed, level-shifting circuit isolates the low-side (V_{SS} pin) referenced circuitry from the high-side (HS pin) referenced driver. Power to the high-side driver and UVLO circuit is supplied by the bootstrap circuit while the voltage level of the HS pin is shifted high.

The bootstrap circuit consists of an internal diode and external capacitor, C_B . In a typical application, such as the synchronous buck converter shown in [Figure 5-3](#), the HS pin is at ground potential while the low-side MOSFET is on. The internal diode allows capacitor C_B to charge up to $V_{DD} - V_D$ during this time (where V_D is the forward voltage drop of the internal diode). After the low-side MOSFET is turned off and the HO pin turns on, the voltage across capacitor C_B is applied to the

MIC4102

gate of the upper external MOSFET. As the upper MOSFET turns on, voltage on the HS pin rises with the source of the high-side MOSFET until it reaches V_{IN} . As the HS and HB pin rise, the internal diode is reverse-biased, preventing capacitor C_B from discharging.

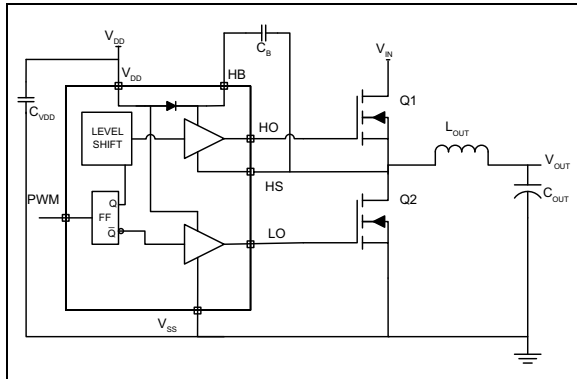

FIGURE 5-3: High-Side Driver and Bootstrap Circuit.

6.0 APPLICATION INFORMATION

6.1 Power Dissipation Considerations

Power dissipation in the driver can be separated into three areas:

- Internal diode dissipation in the bootstrap circuit
- Internal driver dissipation
- Quiescent current dissipation used to supply the internal logic and control functions.

6.2 Bootstrap Circuit Power Dissipation

Power dissipation of the internal bootstrap diode primarily comes from the average charging current of the C_B capacitor times the forward voltage drop of the diode. Secondary sources of diode power dissipation are the reverse leakage current and reverse recovery effects of the diode.

The average current drawn by repeated charging of the high-side MOSFET is calculated by:

EQUATION 6-1:

$$I_{F(AVE)} = Q_{gate} \times f_S$$

Where:

Q_{gate}	Total Gate Charge at V_{HB}
f_S	Gate Drive Switching Frequency

The average power dissipated by the forward voltage drop of the diode equals:

EQUATION 6-2:

$$P_{diode_{fwd}} = I_{F(AVE)} \times V_F$$

Where:

V_F	Diode Forward Voltage Drop
-------	----------------------------

The value of V_F should be taken at the peak current through the diode. However, this current is difficult to calculate because of differences in source impedances. The peak current can either be measured or the value of V_F at the average current can be used and will yield a good approximation of diode power dissipation.

The reverse leakage current of the internal bootstrap diode is typically 11 μA at a reverse voltage of 100V and 125°C. Power dissipation due to reverse leakage is typically much less than 1 mW and can be ignored.

Reverse recovery time is the time required for the injected minority carriers to be swept away from the depletion region during turn-off of the diode. Power dissipation due to reverse recovery can be calculated

by computing the average reverse current due to reverse recovery charge multiplied by the reverse voltage across the diode. The average reverse current and power dissipation due to reverse recovery can be estimated by:

EQUATION 6-3:

$$I_{RR(AVE)} = 2 \times I_{RRM} \times t_{rr} \times f_S$$

Where:

I_{RRM}	Peak Reverse Recovery Current
t_{rr}	Reverse Recovery Time

EQUATION 6-4:

$$P_{diode_{RR}} = I_{RR(AVE)} \times V_{REV}$$

The total diode power dissipation is:

EQUATION 6-5:

$$P_{diode_{total}} = P_{diode_{fwd}} + P_{diode_{RR}}$$

An optional external bootstrap diode may be used instead of the internal diode (Figure 6-1). An external diode may be useful if high gate charge MOSFETs are being driven and the power dissipation of the internal diode is contributing to excessive die temperatures. The voltage drop of the external diode must be less than the internal diode for this option to work. The reverse voltage across the diode will be equal to the input voltage minus the V_{DD} supply voltage. A 100V Schottky diode will work for most 72V input telecom applications. The equations above can be used to calculate power dissipation in the external diode. However, if the external diode has significant reverse leakage current, the power dissipated in that diode due to reverse leakage can be calculated as:

EQUATION 6-6:

$$P_{diode_{REV}} = I_R \times V_{REV} \times (1 - D)$$

Where:

I_R	Reverse Current Flow at V_{REV} & T_J
V_{REV}	Diode Reverse Voltage
D	Duty Cycle = t_{ON}/f_S
f_S	Switching Freq. of Power Supply

MIC4102

The on-time is the time the high-side switch is conducting. In most power supply topologies, the diode is reverse-biased during the switching cycle off-time.

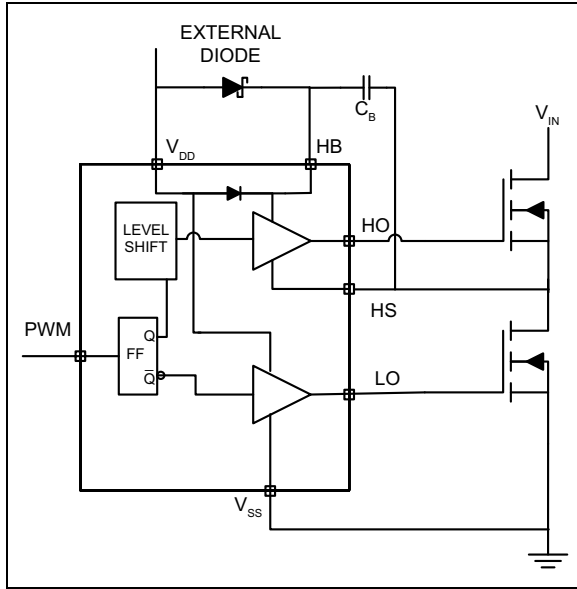

FIGURE 6-1: Optional Bootstrap Diode.

6.3 Gate Drive Power Dissipation

Power dissipation in the output driver stage is mainly caused by charging and discharging the gate to source and gate to drain capacitance of the external MOSFET. Figure 6-2 shows a simplified equivalent circuit of the MIC4102 driving an external high-side MOSFET.

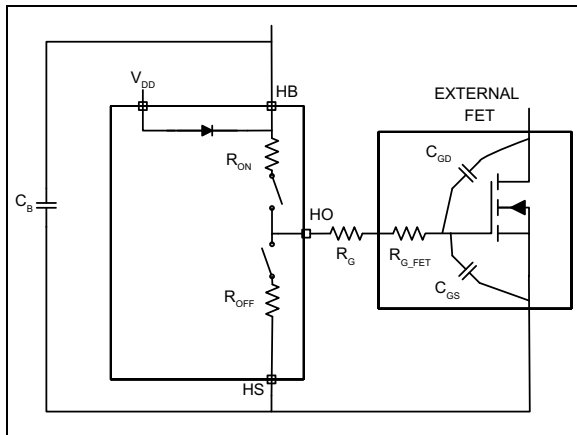

FIGURE 6-2: MIC4102 Driving an External MOSFET.

6.4 Dissipation During the External MOSFET Turn-On

Energy from capacitor C_B is used to charge up the input capacitance of the MOSFET (C_{GD} and C_{GS}). The energy delivered to the MOSFET is dissipated in the three resistive components, R_{ON} , R_G , and R_{G_FET} . R_{ON} is the on resistance of the upper driver MOSFET in the

MIC4102. R_G is the series resistor (if any) between the driver IC and the MOSFET. R_{G_FET} is the gate resistance of the MOSFET. R_{G_FET} is usually listed in the power MOSFET's specifications. The ESR of capacitor C_B and the resistance of the connecting etch can be ignored because they are much less than R_{ON} and R_{G_FET} .

The effective capacitance of C_{GD} and C_{GS} is difficult to calculate because they vary non-linearly with I_D , V_{GS} , and V_{DS} . Fortunately, most power MOSFET specifications include a typical graph of total gate charge vs. V_{GS} . Figure 6-3 shows a typical gate charge curve for an arbitrary power MOSFET. This chart shows that for a gate voltage of 10V, the MOSFET requires about 23.5 nC of charge. The energy dissipated by the resistive components of the gate drive circuit during turn-on is calculated as:

EQUATION 6-7:

$$E = \frac{1}{2} \times C_{ISS} \times V_{GS}^2$$

Where:

C_{ISS} Total Gate Capacitance of MOSFET

but

EQUATION 6-8:

$$Q = C \times V$$

so

EQUATION 6-9:

$$E = \frac{1}{2} \times Q_G \times V_{GS}$$

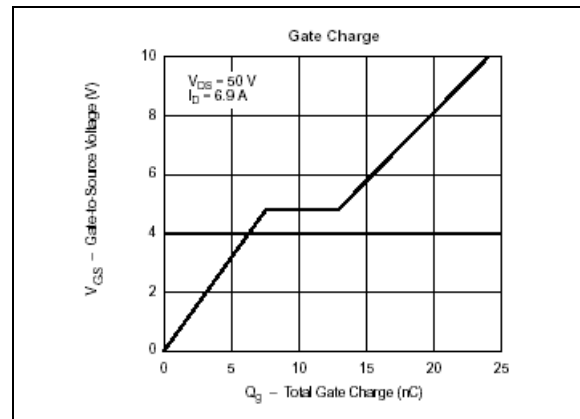

FIGURE 6-3: Typical Gate Charge vs. V_{GS} .

The same energy is dissipated by R_{OFF} , R_G , and R_{G_FET} when the driver IC turns the MOSFET off.

EQUATION 6-10:

$$E_{driver} = \frac{1}{2} \times Q_G \times V_{GS}$$

Where:

E_{driver} Energy Dissipated during Turn-On or Turn-Off

and

EQUATION 6-11:

$$P_{driver} = \frac{1}{2} \times Q_G \times V_{GS} \times f_S$$

Where:

P_{driver} Power Dissipated during Turn-On or Turn-Off
 Q_G Total Gate Charge at V_{GS}
 V_{GS} Gate-to-Source Voltage on the MOSFET
 f_S Switching Frequency of the Gate Drive Circuit

The power dissipated inside the MIC4102 equals the ratio of R_{ON} and R_{OFF} to the external resistive losses in R_G and R_{G_FET} . The power dissipated in the MIC4102 due to driving the external MOSFET is:

EQUATION 6-12:

$$P_{diss_drive} = P_{driver} \times \frac{R_{ON}}{R_{ON} + R_G + R_{G_FET}} + P_{driver} \times \frac{R_{OFF}}{R_{OFF} + R_G + R_{G_FET}}$$

6.5 Supply Current Power Dissipation

Power is dissipated in the MIC4102 even if there is nothing being driven. The supply current is drawn by the bias for the internal circuitry, the level shifting circuitry, and shoot-through current in the output drivers. The supply current is proportional to operating frequency and the V_{DD} and V_{HB} voltages. The typical characteristic graphs show how supply current varies with switching frequency and supply voltage.

The power dissipated by the MIC4102 due to supply current is:

EQUATION 6-13:

$$P_{diss_supply} = V_{DD} \times I_{DD} + V_{HB} \times I_{HB}$$

6.6 Total Power Dissipation and Thermal Considerations

Total power dissipation in the MIC4102 equals the power dissipation caused by driving the external MOSFETs, the supply current, and the internal bootstrap diode.

EQUATION 6-14:

$$P_{diss_total} = P_{diss_supply} + P_{diss_drive} + P_{diode_total}$$

The die temperature may be calculated once the total power dissipation is known.

EQUATION 6-15:

$$T_J = T_A + P_{diss_total} \times \theta_{JA}$$

Where:

T_J Junction Temperature
 T_A Maximum Ambient Temperature
 P_{diss_total} Power Dissipation of the MIC4102
 θ_{JA} Thermal Resistance from Junction to Ambient Air

6.7 Anti-Shoot-Through, Propagation Delay, and Other Timing Considerations

The block diagram on page two illustrates how the MIC4102 drives the power stage of a synchronous buck converter. It is important that only one of the two MOSFETs is on at any given time. If both MOSFETs are simultaneously on, they will short V_{IN} to ground, causing high current from the V_{IN} supply to “shoot through” the MOSFETs and into ground. Excessive shoot-through causes higher power dissipation in the MOSFETs, voltage spikes, and ringing in the circuit. The high current and voltage ringing generate conducted and radiated EMI.

Minimizing shoot-through can be done passively, actively, or through a combination of both. Passive shoot-through protection uses delays between the high and low gate drivers to prevent both MOSFETs from being on at the same time. These delays can be adjusted for different applications. Although simple, the

MIC4102

disadvantage of this approach is the long delays required to account for process and temperature variations in the MOSFET and the MOSFET driver.

Active shoot-through monitors voltages on the gate drive outputs and switch node to determine when to switch the MOSFETs on and off. This active approach adjusts the delays to account for some of the variations, but it also has its disadvantages. High currents and fast switching voltages in the gate drive and return paths can cause parasitic ringing that may turn the MOSFETs back on even though the gate driver output is low. Another disadvantage is that the driver cannot monitor the gate voltage inside the MOSFET. Figure 6-4 shows an equivalent circuit, including parasitics, of the gate driver section. The internal gate resistance (R_{G_GATE}) and any external damping resistor (R_G) isolate the MOSFET's gate from the driver output. There is a delay between when the driver output goes low and the MOSFET turns off. This turn-off delay is usually specified in the MOSFET data sheet. This delay increases when an external damping resistor is used.

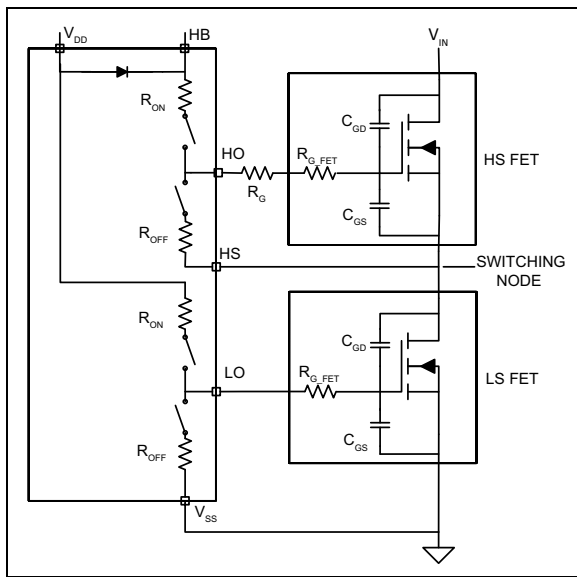

FIGURE 6-4: Gate Drive Circuit with Parasitics.

The MIC4102 uses a combination of active sensing and passive delay to ensure that both MOSFETs are not on at the same time and to minimize shoot-through current. The timing diagram helps illustrate how the anti-shoot-through circuitry works. A high level on the PWM pin causes the LO pin to go low. The MIC4102 monitors the LO pin voltage and prevents the HO pin from turning on until the voltage on the LO pin reaches the V_{L_OFF} threshold. After a short delay, the MIC4102 drives the HO pin high. Monitoring the LO voltage eliminates any excessive delay due to the MOSFET drivers turn-off time and the short delay accounts for the MOSFET turn-off delay as well as letting the LO pin

voltage settle out. An external resistor between the LO output and the MOSFET may affect the performance of the LO pin monitoring circuit and is not recommended.

A low on the PWM pin causes the HO pin to go low after a short delay (t_{HO_OFF}). Before the LO pin can go high, the voltage on the switching node (HS pin) must have dropped to 2.5V below the V_{DD} voltage. Monitoring the switch voltage instead of the HO pin voltage eliminates timing variations and excessive delays due to the high side MOSFET turn-off. The LO driver turns on after a short delay (t_{LO_ON}). Once the LO driver is turned on, it is latched on until the PWM signal goes high. This prevents any ringing or oscillations on the switch node or HS pin from turning off the LO driver. If the PWM pin goes low and the voltage on the HS pin does not cross the V_{SWth} threshold, the LO pin will be forced high after a short delay (t_{SWTO}), ensuring proper operation.

Fast propagation delay between the input and output drive waveform is desirable. It improves overcurrent protection by decreasing the response time between the control signal and the MOSFET gate drive. Minimizing propagation delay also minimizes phase shift errors in power supplies with wide bandwidth control loops.

Care must be taken to ensure the input signal pulse width is greater than the minimum specified pulse width. An input signal that is less than the minimum pulse width may result in no output pulse or an output pulse whose width is significantly less than the input.

The maximum duty cycle (ratio of high-side on-time to switching period) is determined by the time required for the C_B capacitor to charge during the off-time. Adequate time must be allowed for the C_B capacitor to charge up before the high-side driver is turned back on.

The anti-shoot-through circuit in the MIC4102 prevents the driver from turning both MOSFETs on at the same time; however, other factors outside of the anti-shoot-through circuit's control can cause shoot-through. Some of these include ringing on the gate drive node and capacitive coupling of the switching node voltage on the gate of the low-side MOSFET.

6.8 Decoupling and Bootstrap Capacitor Selection

Decoupling capacitors are required for both the low-side (V_{DD}) and high-side (HB) supply pins. These capacitors supply the charge necessary to drive the external MOSFETs as well as minimize the voltage ripple on these pins. The capacitor from HB to HS serves double duty by providing decoupling for the high-side circuitry as well as providing current to the high-side circuit while the high-side external MOSFET is on. Ceramic capacitors are recommended because of their low impedance and small size. Z5U type ceramic capacitor dielectrics are not recommended due to the large change in capacitance over

temperature and voltage. A minimum value of 0.1 μF is required for each of the capacitors, regardless of the MOSFETs being driven. Larger MOSFETs may require larger capacitance values for proper operation. The voltage rating of the capacitors depends on the supply voltage, ambient temperature, and the voltage derating used for reliability. 25V rated X5R or X7R ceramic capacitors are recommended for most applications. The minimum capacitance value should be increased if low voltage capacitors are used because even good quality dielectric capacitors, such as X5R, will lose 40% to 70% of their capacitance value at the rated voltage.

Placement of the decoupling capacitors is critical. The bypass capacitor for V_{DD} should be placed as close as possible between the V_{DD} and V_{SS} pins. The bypass capacitor (C_{B}) for the HB supply pin must be located as close as possible between the HB and HS pins. The etch connections must be short, wide, and direct. The use of a ground plane to minimize connection impedance is recommended. Refer to the section on layout and component placement for more information.

The voltage on the bootstrap capacitor drops each time it delivers charge to turn on the MOSFET. The voltage drop depends on the gate charge required by the MOSFET. Most MOSFET specifications specify gate charge vs. V_{GS} voltage. Based on this information and a recommended ΔV_{HB} of less than 0.1V, the minimum value of bootstrap capacitance is calculated as:

EQUATION 6-16:

$$C_B \geq \frac{Q_G}{\Delta V_{\text{HB}}}$$

Where:

Q_G	Total Gate Charge at V_{HB}
ΔV_{HB}	Voltage Drop at the HB Pin

The decoupling capacitor for the V_{DD} input may be calculated in with the same formula; however, the two capacitors are usually equal in value.

6.9 Grounding, Component Placement, and Circuit Layout

Nanosecond switching speeds and ampere peak currents in and around the MIC4102 driver require proper placement and trace routing of all components. Improper placement may cause degraded noise immunity, false switching, excessive ringing, or circuit latch-up.

Figure 6-5 shows the critical current paths when the driver outputs go high and turn on the external MOSFETs. It also shows the need for a low impedance ground plane. The charge needed to turn-on the MOSFET gates comes from the decoupling capacitors C_{VDD} and C_{B} . Current in the low-side gate driver flows

from C_{VDD} through the internal driver, into the MOSFET gate, and out the source. The return connection back to the decoupling capacitor is made through the ground plane. Any inductance or resistance in the ground return path causes a voltage spike or ringing to appear on the source of the MOSFET. This voltage works against the gate voltage and can either slow down or turn off the MOSFET during the period where it should be turned on.

Current in the high-side driver is sourced from capacitor C_{B} , flows into the HB pin, and out the HO pin, into the gate of the high-side MOSFET. The return path for the current is from the source of the MOSFET and back to capacitor C_{B} . The high-side circuit return path usually does not have a low impedance ground plane, so the etch connections in this critical path should be short and wide to minimize parasitic inductance. As with the low-side circuit, impedance between the MOSFET source and the decoupling capacitor causes negative voltage feedback that fights the turn-on of the MOSFET.

It is important to note that capacitor C_{B} must be placed close to the HB and HS pins. This capacitor not only provides all the energy for turn-on, but it must also keep HB pin noise and ripple low for proper operation of the high-side drive circuitry.

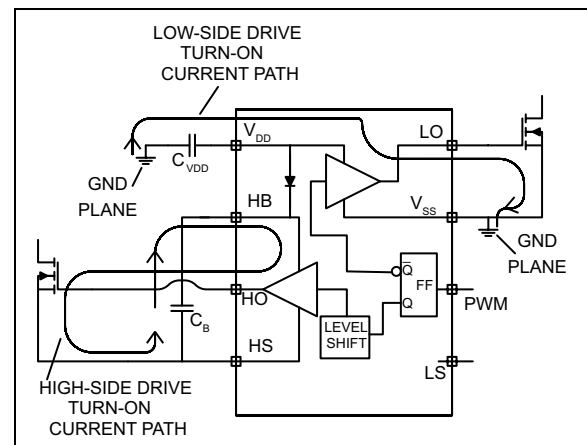

FIGURE 6-5: Turn-On Current Paths.

Figure 6-6 shows the critical current paths when the driver outputs go low and turn off the external MOSFETs. Short, low impedance connections are important during turn-off for the same reasons given in the turn-on explanation. Current flowing through the internal diode replenishes charge in the bootstrap capacitor, C_{B} .

MIC4102

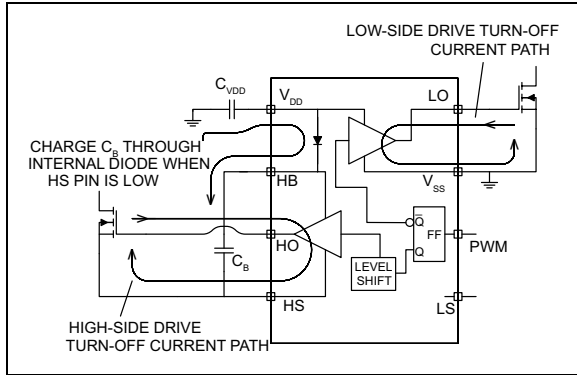

FIGURE 6-6: Turn-Off Current Paths.

The following circuit guidelines should be adhered to for optimum circuit performance:

- The V_{DD} and HB bypass capacitors must be placed close to the supply and ground pins. It is critical that the etch length between the high side decoupling capacitor (C_B) and the HB and HS pins be minimized to reduce lead inductance.
- A ground plane should be used to minimize parasitic inductance and impedance of the return paths. The MIC4102 is capable of greater than 3A peak currents. Any impedance between the MIC4102, the decoupling capacitors, and the external MOSFET will degrade the performance of the driver.
- Trace out the high d_i/d_t and d_v/d_t paths, as shown in Figure 6-5 and Figure 6-6 to minimize the etch length and loop area for these connections. Minimizing these parameters decreases the parasitic inductance and the radiated EMI generated by fast rise and fall times.

A typical layout of a synchronous buck converter power stage using the MIC4102 (Figure 6-7) is shown in Figure 6-8.

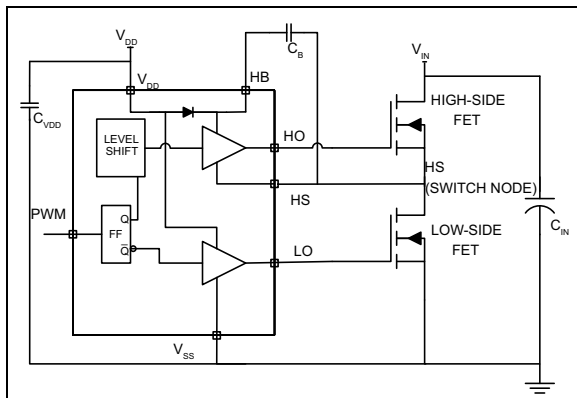

FIGURE 6-7: Typical Converter Power Stage.

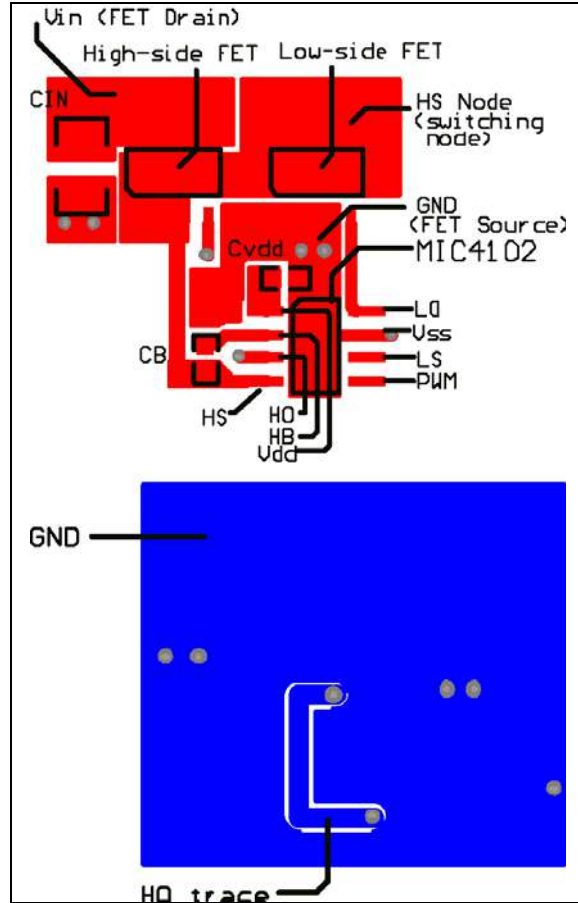
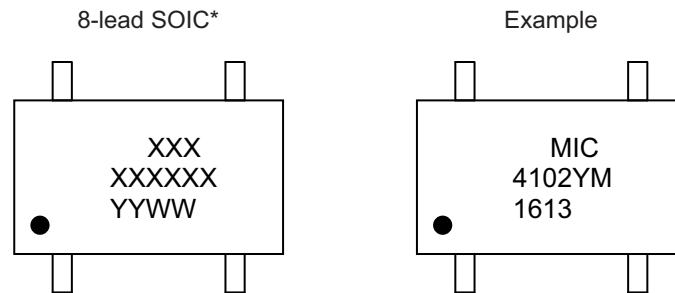

FIGURE 6-8: Typical Layout of a Synchronous Buck Converter Power Stage.

The circuit is configured as a synchronous buck power stage. The high-side MOSFET drain connects to the input supply voltage (drain) and the source connects to the switching node. The low-side MOSFET drain connects to the switching node and its source is connected to ground. The buck converter output inductor (not shown) would connect to the switching node. The high-side drive trace, HO, is routed on top of its return trace, HS, to minimize loop area and parasitic inductance. The low-side drive trace, LO, is routed over the ground plane and minimizes the impedance of that current path. The decoupling capacitors, C_B and C_{VDD} , are placed to minimize etch length between the capacitors and their respective pins. This close placement is necessary to efficiently charge capacitor C_B when the HS node is low. All traces are 0.025" wide or greater to reduce impedance. C_{IN} is used to decouple the high current path through the MOSFETs.

7.0 PACKAGING INFORMATION

7.1 Package Marking Information



<p>Legend:</p> <p>XX...X Product code or customer-specific information</p> <p>Y Year code (last digit of calendar year)</p> <p>YY Year code (last 2 digits of calendar year)</p> <p>WW Week code (week of January 1 is week '01')</p> <p>NNN Alphanumeric traceability code</p> <p>(e3) Pb-free JEDEC® designator for Matte Tin (Sn)</p> <p>* This package is Pb-free. The Pb-free JEDEC designator ((e3)) can be found on the outer packaging for this package.</p> <p>●, ▲, ▼ Pin one index is identified by a dot, delta up, or delta down (triangle mark).</p>	<p>Note: In the event the full Microchip part number cannot be marked on one line, it will be carried over to the next line, thus limiting the number of available characters for customer-specific information. Package may or may not include the corporate logo.</p> <p>Underbar (_) symbol may not be to scale.</p>
---	--

MIC4102

8-Lead SOIC Package Outline and Recommended Land Pattern

Note: For the most current package drawings, please see the Microchip Packaging Specification located at <http://www.microchip.com/packaging>

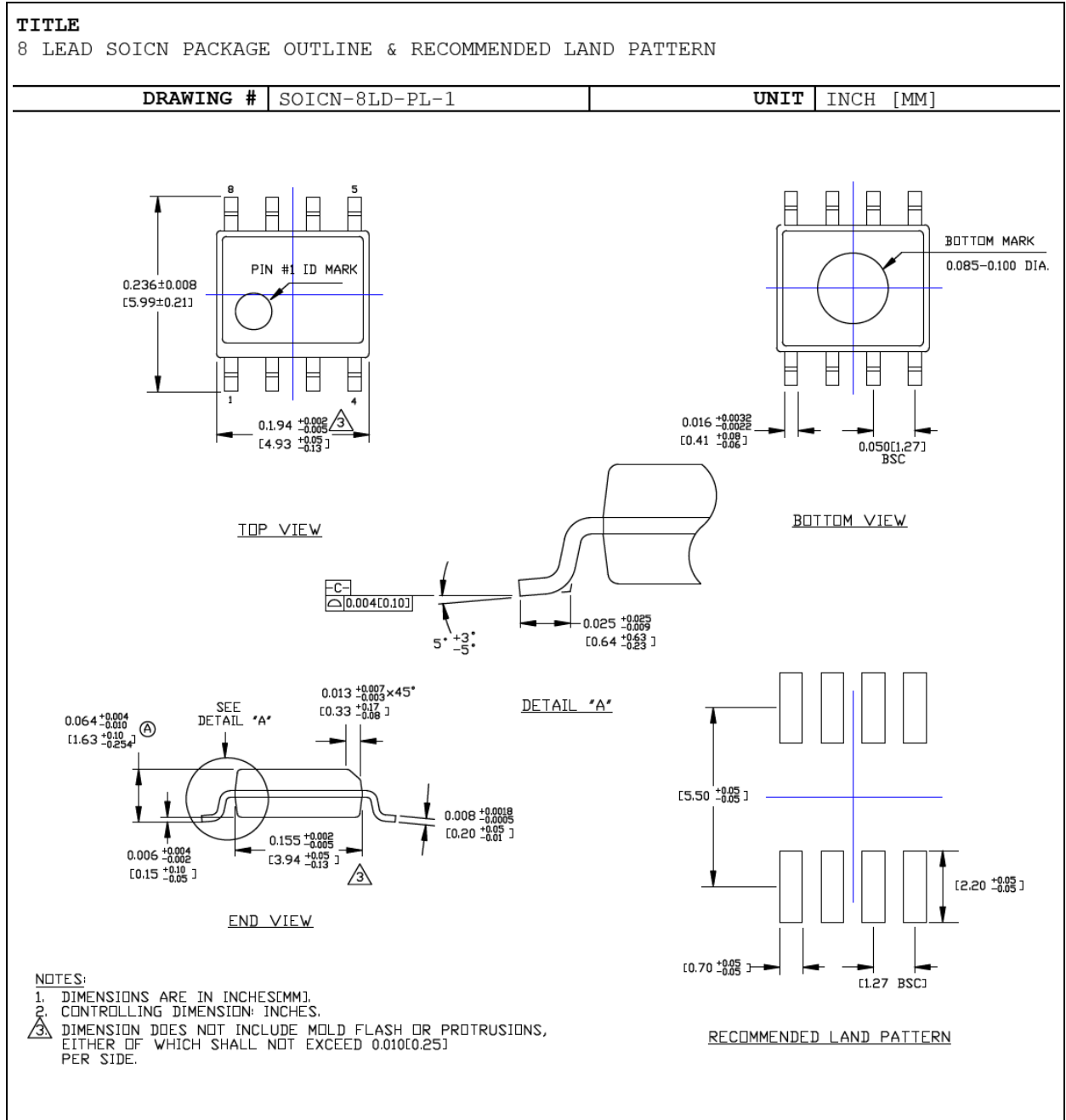

APPENDIX A: REVISION HISTORY

Revision A (June 2016)

- Converted Micrel document MIC4102 to Microchip data sheet DS20005575A.
- Minor text changes throughout.

MIC4102

NOTES:

PRODUCT IDENTIFICATION SYSTEM

To order or obtain information, e.g., on pricing or delivery, contact your local Microchip representative or sales office.

<u>PART NO.</u>		X	X	—	XX
Device	Temperature	Package	Media Type		
Device:	MIC4102:	100V Half-Bridge MOSFET Driver with Anti-Shoot-Through Protection			
Temperature:	Y =	-40°C to +125°C			
Package:	M =	SOIC-8L			
Media Type:	(blank) =	95/Tube			
	TR =	2,500/Reel			

Examples:	
a) MIC4102YM:	100V Half-Bridge MOS-FET Driver with Anti-Shoot-Through Protection, -40°C to +125°C Temp. Range, SOIC-8L Package, 95/Tube
b) MIC4102YM-TR:	100V Half-Bridge MOS-FET Driver with Anti-Shoot-Through Protection, -40°C to +125°C Temp. Range, SOIC-8L Package, 2,500/Reel

MIC4102

NOTES:

Note the following details of the code protection feature on Microchip devices:

- Microchip products meet the specification contained in their particular Microchip Data Sheet.
- Microchip believes that its family of products is one of the most secure families of its kind on the market today, when used in the intended manner and under normal conditions.
- There are dishonest and possibly illegal methods used to breach the code protection feature. All of these methods, to our knowledge, require using the Microchip products in a manner outside the operating specifications contained in Microchip's Data Sheets. Most likely, the person doing so is engaged in theft of intellectual property.
- Microchip is willing to work with the customer who is concerned about the integrity of their code.
- Neither Microchip nor any other semiconductor manufacturer can guarantee the security of their code. Code protection does not mean that we are guaranteeing the product as “unbreakable.”

Code protection is constantly evolving. We at Microchip are committed to continuously improving the code protection features of our products. Attempts to break Microchip's code protection feature may be a violation of the Digital Millennium Copyright Act. If such acts allow unauthorized access to your software or other copyrighted work, you may have a right to sue for relief under that Act.

Information contained in this publication regarding device applications and the like is provided only for your convenience and may be superseded by updates. It is your responsibility to ensure that your application meets with your specifications. MICROCHIP MAKES NO REPRESENTATIONS OR WARRANTIES OF ANY KIND WHETHER EXPRESS OR IMPLIED, WRITTEN OR ORAL, STATUTORY OR OTHERWISE, RELATED TO THE INFORMATION, INCLUDING BUT NOT LIMITED TO ITS CONDITION, QUALITY, PERFORMANCE, MERCHANTABILITY OR FITNESS FOR PURPOSE. Microchip disclaims all liability arising from this information and its use. Use of Microchip devices in life support and/or safety applications is entirely at the buyer's risk, and the buyer agrees to defend, indemnify and hold harmless Microchip from any and all damages, claims, suits, or expenses resulting from such use. No licenses are conveyed, implicitly or otherwise, under any Microchip intellectual property rights unless otherwise stated.

Microchip received ISO/TS-16949:2009 certification for its worldwide headquarters, design and wafer fabrication facilities in Chandler and Tempe, Arizona; Gresham, Oregon and design centers in California and India. The Company's quality system processes and procedures are for its PIC® MCUs and dsPIC® DSCs, KEELoc® code hopping devices, Serial EEPROMs, microperipherals, nonvolatile memory and analog products. In addition, Microchip's quality system for the design and manufacture of development systems is ISO 9001:2000 certified.

**QUALITY MANAGEMENT SYSTEM
CERTIFIED BY DNV
= ISO/TS 16949 =**

Trademarks

The Microchip name and logo, the Microchip logo, AnyRate, dsPIC, FlashFlex, flexPWR, Heldo, JukeBlox, KeeLoq, KeeLoq logo, Klear, LANCheck, LINK MD, MediaLB, MOST, MOST logo, MPLAB, OptoLyzer, PIC, PICSTART, PIC32 logo, RightTouch, SpyNIC, SST, SST Logo, SuperFlash and UNI/O are registered trademarks of Microchip Technology Incorporated in the U.S.A. and other countries.

ClockWorks, The Embedded Control Solutions Company, ETHERSYNCH, Hyper Speed Control, HyperLight Load, IntellIMOS, mTouch, Precision Edge, and QUIET-WIRE are registered trademarks of Microchip Technology Incorporated in the U.S.A.

Analog-for-the-Digital Age, Any Capacitor, AnyIn, AnyOut, BodyCom, chipKIT, chipKIT logo, CodeGuard, dsPICDEM, dsPICDEM.net, Dynamic Average Matching, DAM, ECAN, EtherGREEN, In-Circuit Serial Programming, ICSP, Inter-Chip Connectivity, JitterBlocker, KlearNet, KlearNet logo, MiWi, motorBench, MPASM, MPF, MPLAB Certified logo, MPLIB, MPLINK, MultiTRAK, NetDetach, Omniscient Code Generation, PICDEM, PICDEM.net, PICkit, PICtail, PureSilicon, RightTouch logo, REAL ICE, Ripple Blocker, Serial Quad I/O, SQL, SuperSwitcher, SuperSwitcher II, Total Endurance, TSHARC, USBCheck, VariSense, ViewSpan, WiperLock, Wireless DNA, and ZENA are trademarks of Microchip Technology Incorporated in the U.S.A. and other countries.

SQTP is a service mark of Microchip Technology Incorporated in the U.S.A.

Silicon Storage Technology is a registered trademark of Microchip Technology Inc. in other countries.

GestIC is a registered trademarks of Microchip Technology Germany II GmbH & Co. KG, a subsidiary of Microchip Technology Inc., in other countries.

All other trademarks mentioned herein are property of their respective companies.

© 2016, Microchip Technology Incorporated, Printed in the U.S.A., All Rights Reserved.

ISBN: 978-1-5224-0717-1



MICROCHIP

Worldwide Sales and Service

AMERICAS

Corporate Office

2355 West Chandler Blvd.
Chandler, AZ 85224-6199
Tel: 480-792-7200
Fax: 480-792-7277
Technical Support:
<http://www.microchip.com/support>

Web Address:

www.microchip.com

Atlanta

Duluth, GA
Tel: 678-957-9614
Fax: 678-957-1455

Austin, TX

Tel: 512-257-3370

Boston

Westborough, MA
Tel: 774-760-0087
Fax: 774-760-0088

Chicago

Itasca, IL
Tel: 630-285-0071
Fax: 630-285-0075

Cleveland

Independence, OH
Tel: 216-447-0464
Fax: 216-447-0643

Dallas

Addison, TX
Tel: 972-818-7423
Fax: 972-818-2924

Detroit

Novi, MI
Tel: 248-848-4000

Houston, TX

Tel: 281-894-5983

Indianapolis

Noblesville, IN
Tel: 317-773-8323
Fax: 317-773-5453

Los Angeles

Mission Viejo, CA
Tel: 949-462-9523
Fax: 949-462-9608

New York, NY

Tel: 631-435-6000

San Jose, CA

Tel: 408-735-9110

Canada - Toronto

Tel: 905-673-0699
Fax: 905-673-6509

ASIA/PACIFIC

Asia Pacific Office

Suites 3707-14, 37th Floor
Tower 6, The Gateway
Harbour City, Kowloon

Hong Kong

Tel: 852-2943-5100
Fax: 852-2401-3431

Australia - Sydney

Tel: 61-2-9868-6733
Fax: 61-2-9868-6755

China - Beijing

Tel: 86-10-8569-7000
Fax: 86-10-8528-2104

China - Chengdu

Tel: 86-28-8665-5511
Fax: 86-28-8665-7889

China - Chongqing

Tel: 86-23-8980-9588
Fax: 86-23-8980-9500

China - Dongguan

Tel: 86-769-8702-9880

China - Hangzhou

Tel: 86-571-8792-8115
Fax: 86-571-8792-8116

China - Hong Kong SAR

Tel: 852-2943-5100
Fax: 852-2401-3431

China - Nanjing

Tel: 86-25-8473-2460
Fax: 86-25-8473-2470

China - Qingdao

Tel: 86-532-8502-7355
Fax: 86-532-8502-7205

China - Shanghai

Tel: 86-21-5407-5533
Fax: 86-21-5407-5066

China - Shenyang

Tel: 86-24-2334-2829
Fax: 86-24-2334-2393

China - Shenzhen

Tel: 86-755-8864-2200
Fax: 86-755-8203-1760

China - Wuhan

Tel: 86-27-5980-5300
Fax: 86-27-5980-5118

China - Xian

Tel: 86-29-8833-7252
Fax: 86-29-8833-7256

ASIA/PACIFIC

China - Xiamen

Tel: 86-592-2388138
Fax: 86-592-2388130

China - Zhuhai

Tel: 86-756-3210040
Fax: 86-756-3210049

India - Bangalore

Tel: 91-80-3090-4444
Fax: 91-80-3090-4123

India - New Delhi

Tel: 91-11-4160-8631
Fax: 91-11-4160-8632

India - Pune

Tel: 91-20-3019-1500

Japan - Osaka

Tel: 81-6-6152-7160
Fax: 81-6-6152-9310

Japan - Tokyo

Tel: 81-3-6880-3770
Fax: 81-3-6880-3771

Korea - Daegu

Tel: 82-53-744-4301
Fax: 82-53-744-4302

Korea - Seoul

Tel: 82-2-554-7200
Fax: 82-2-558-5932 or
82-2-558-5934

Malaysia - Kuala Lumpur

Tel: 60-3-6201-9857
Fax: 60-3-6201-9859

Malaysia - Penang

Tel: 60-4-227-8870
Fax: 60-4-227-4068

Philippines - Manila

Tel: 63-2-634-9065
Fax: 63-2-634-9069

Singapore

Tel: 65-6334-8870
Fax: 65-6334-8850

Taiwan - Hsin Chu

Tel: 886-3-5778-366
Fax: 886-3-5770-955

Taiwan - Kaohsiung

Tel: 886-7-213-7828

Taiwan - Taipei

Tel: 886-2-2508-8600
Fax: 886-2-2508-0102

Thailand - Bangkok

Tel: 66-2-694-1351
Fax: 66-2-694-1350

EUROPE

Austria - Wels

Tel: 43-7242-2244-39
Fax: 43-7242-2244-393

Denmark - Copenhagen

Tel: 45-4450-2828
Fax: 45-4485-2829

France - Paris

Tel: 33-1-69-53-63-20
Fax: 33-1-69-30-90-79

Germany - Dusseldorf

Tel: 49-2129-3766400

Germany - Karlsruhe

Tel: 49-721-625370

Germany - Munich

Tel: 49-89-627-144-0
Fax: 49-89-627-144-44

Italy - Milan

Tel: 39-0331-742611
Fax: 39-0331-466781

Italy - Venice

Tel: 39-049-7625286

Netherlands - Drunen

Tel: 31-416-690399
Fax: 31-416-690340

Poland - Warsaw

Tel: 48-22-3325737

Spain - Madrid

Tel: 34-91-708-08-90
Fax: 34-91-708-08-91

Sweden - Stockholm

Tel: 46-8-5090-4654

UK - Wokingham

Tel: 44-118-921-5800
Fax: 44-118-921-5820

07/14/15