



ON Semiconductor®

<http://onsemi.com>

STK672-080-E

Thick-Film Hybrid IC

**Unipolar Constant-current Chopper (external excitation PWM) Circuit with Built-in Microstepping Controller Stepping Motor Driver (sine wave drive)
Output Current 2.8A (no heat sink*)**

Overview

The STK672-080-E is a stepping motor driver hybrid IC that uses power MOSFETs in the output stage. It includes a built-in microstepping controller and is based on a unipolar constant-current PWM system. The STK672-080-E supports application simplification and standardization by providing a built-in 4 phase distribution stepping motor controller. It supports five excitation methods: 2 phase, 1-2 phase, W1-2 phase, 2W1-2 phase, and 4W1-2 phase excitations, and can provide control of the basic stepping angle of the stepping motor divided into 1/16 step units. It also allows the motor speed to be controlled with only a clock signal.

The use of this hybrid IC allows designers to implement systems that provide high motor torques, low vibration levels, low noise, fast response, and high-efficiency drive.

This product is provided in a smaller package than earlier STK672-050-E for easier mounting in end products.

Applications

- Facsimile stepping motor drive (send and receive)
- Paper feed and optical system stepping motor drive in copiers
- Laser printer drum drive
- Printer carriage stepping motor drive
- X-Y plotter pen drive
- Other stepping motor applications

Note*: Conditions: $V_{CC1} = 24V$, $I_{OH} = 2.0A$, 2W1-2 excitation mode.

Features

- Can implement stepping motor drive systems simply by providing a DC power supply and a clock pulse generator.

<Control Block Features>

- One of five drive types can be selected with the drive mode settings (M1, M2, and M3)
 - 1) 2 phase excitation drive
 - 2) 1-2 phase excitation drive
 - 3) W1-2 phase excitation drive
 - 4) 2W1-2 phase excitation drive
 - 5) 4W1-2 phase excitation drive
- Phase retention even if excitation is switched.
- Provides the MOI phase origin monitor pin.
- The CLK input counter block can be selected to be one of the following by the high/low setting of the M3 input pin.
 - 1) Rising edge only
 - 2) Both rising and falling edges
- The CLK input pin includes built-in malfunction prevention circuits for external pulse noise.
- ENABLE and RESET pins provided. These are Schmitt trigger inputs with built-in 20kΩ (typical) pull-up resistors.
- No noise generation due to the difference between the A and B phase time constants during motor hold since external excitation is used.
- Microstepping operation supported even for small motor currents, since the reference voltage Vref can be set to any value between 0V and 1/2VCC2.

<Driver Block>

- External excitation PWM drive allows a wide operating supply voltage range ($V_{CC1} = 10$ to $45V$) to be used.
- Current detection resistor (0.15Ω) built-in the hybrid IC itself.
- Power MOSFETs adopted for low drive loss.
- Provides a motor output drive current of $I_{OH} = 2.8A$. (at $T_c = 105^\circ C$)

Specifications

Absolute Maximum Ratings at $T_a = 25^\circ C$

Parameter	Symbol	Conditions	Ratings	Unit
Maximum supply voltage 1	V_{CC1} max	No signal	52	V
Maximum supply voltage 2	V_{CC2} max	No signal	-0.3 to +7.0	V
Input voltage	V_{IN} max	Logic input pins	-0.3 to +7.0	V
Output current	I_{OH} max	0.5s, 1 pulse, with V_{CC1} applied	3.3	A
Repeated avalanche capacity	Ear max		30	mJ
Allowable power dissipation	P_d max	$\theta_{c-a} = 0$	8	W
Operating IC substrate temperature	T_c max		105	$^\circ C$
Junction temperature	T_j max		150	$^\circ C$
Storage temperature	T_{stg}		-40 to +125	$^\circ C$

Stresses exceeding Maximum Ratings may damage the device. Maximum Ratings are stress ratings only. Functional operation above the Recommended Operating Conditions is not implied. Extended exposure to stresses above the Recommended Operating Conditions may affect device reliability.

Allowable Operating Ranges at $T_a = 25^\circ C$

Parameter	Symbol	Conditions	Ratings	Unit
Supply voltage 1	V_{CC1}	With signals applied	10 to 45	V
Supply voltage 2	V_{CC2}	With signals applied	$5 \pm 5\%$	V
Input voltage	V_{IH}		0 to V_{CC2}	V
Phase driver withstand voltage	V_{DSS}	Tr1, 2, 3, and 4 (the A, \bar{A} , B, and \bar{B} outputs)	100 (min)	V
Output current 1	I_{OH1}	$T_c = 105^\circ C$, $CLK \geq 200Hz$	2.8	A
Output current 2	I_{OH2}	$T_c = 80^\circ C$, $CLK \geq 200Hz$	3	A

STK672-080-E

Electrical Characteristics at $T_c = 25^\circ\text{C}$, $V_{CC1} = 24\text{V}$, $V_{CC2} = 5\text{V}$

Parameters	Symbols	Conditions	Rating			unit
			min	typ	max	
Control supply current	I_{CC}	Pin 6, with ENABLE pin held low.		2.1	14	mA
Output saturation voltage	V_{sat}	$R_L = 12\Omega$		0.65	1	V
Average output current	I_{oave}	Load: $R = 3.5\Omega / L = 3.8\text{mH}$ For each phase	0.445	0.5	0.56	A
FET diode forward voltage	V_{df}	$I_f = 1\text{A}$		1	1.5	V
[Control Inputs]						
Input voltage	V_{IH}	Except for the V_{ref} pin	4			V
	V_{IL}	Except for the V_{ref} pin			1	V
Input current	I_{IH}	Except for the V_{ref} pin	0	1	10	μA
	I_{IL}	Except for the V_{ref} pin	125	250	510	μA
[Vref Input Pin]						
Input voltage	V_I	Pin 7	0		2.5	V
Input current	I_I	Pin 7, 2.5V input	330	415	545	μA
[Control Outputs]						
Output voltage	V_{OH}	$I = -3\text{mA}$, pins MOI	2.4			V
	V_{OL}	$I = +3\text{mA}$, pins MOI			0.4	V
[Current Distribution Ratio (A-B)]						
2W1-2, W1-2, 1-2	V_{ref}	$\theta = 1/8$		100		%
2W1-2, W1-2	V_{ref}	$\theta = 2/8$		92		%
2W1-2	V_{ref}	$\theta = 3/8$		83		%
2W1-2, W1-2, 1-2	V_{ref}	$\theta = 4/8$		71		%
2W1-2	V_{ref}	$\theta = 5/8$		55		%
2W1-2, W1-2	V_{ref}	$\theta = 6/8$		40		%
2W1-2	V_{ref}	$\theta = 7/8$		21		%
2	V_{ref}			100		%
PWM frequency	f_c		37	47	57	kHz

Note: A constant-voltage power supply must be used.

The design target value is shown for the current distribution ratio.

Package Dimensions

unit:mm (typ)

4186

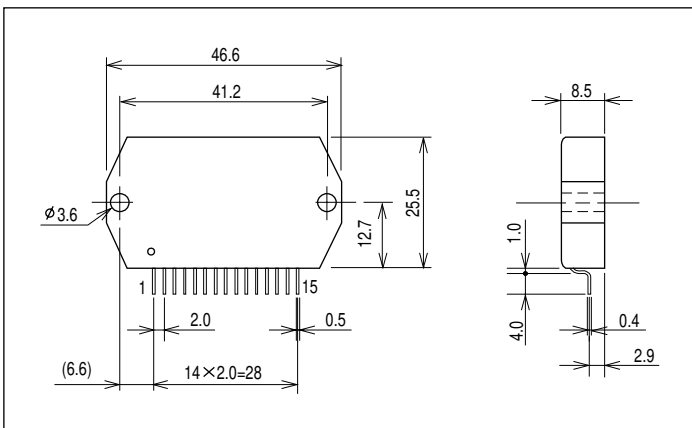

Internal Block Diagram

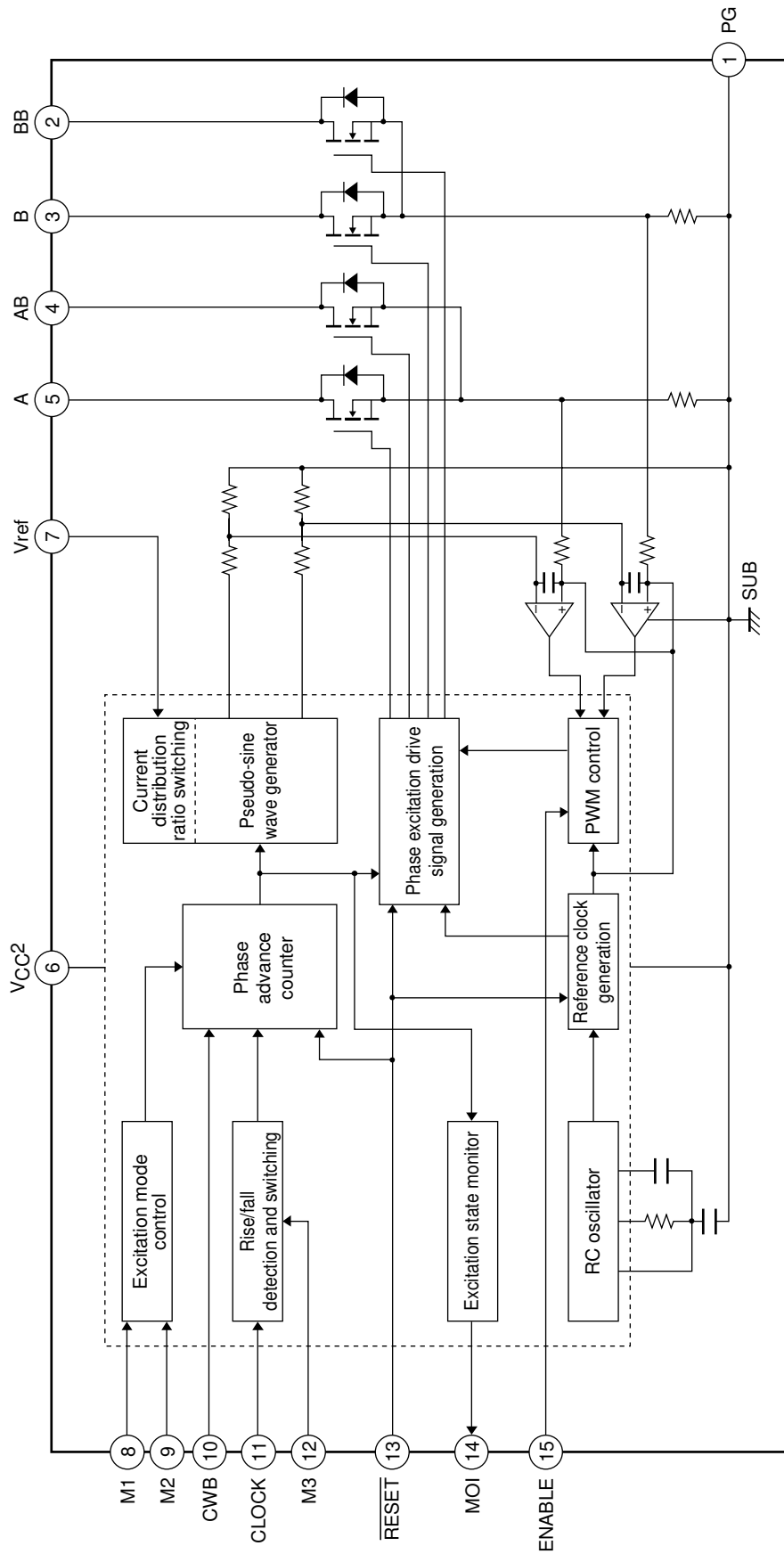

A13256

Test Circuit Diagrams

Vsat

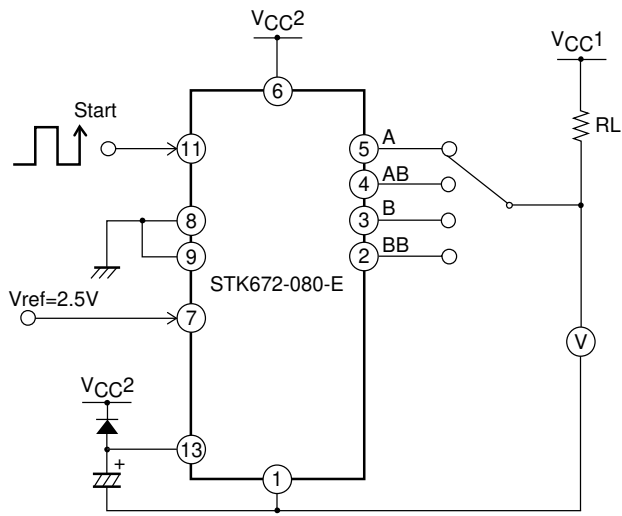

A13257

Vdf

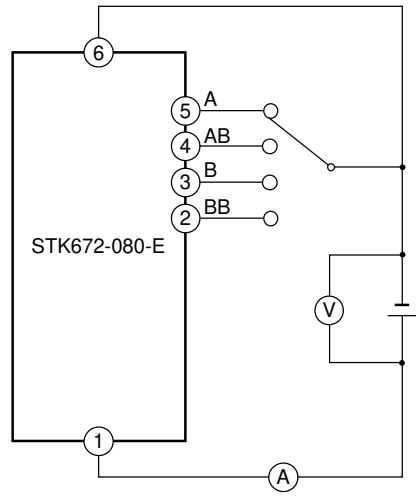

A13258

I_{IH}, I_{IL}

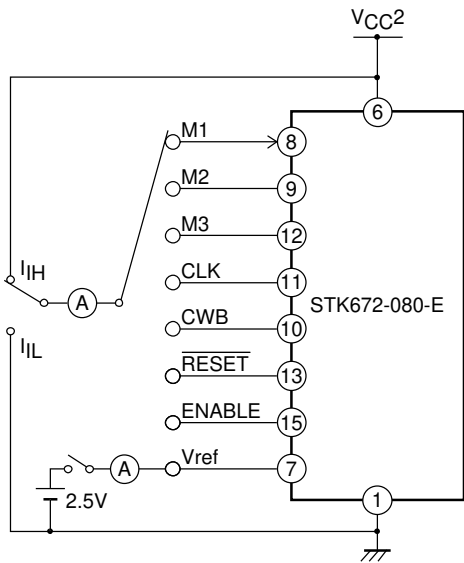

A13259

I_{oave}, I_{CC}, f_c

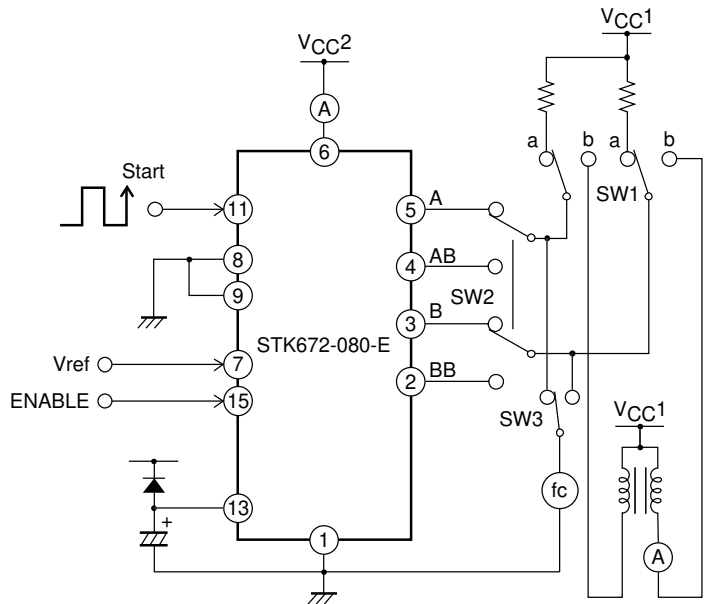

A13260

For I_{oave} measurement: Set switch SW1 to the b position, provide the Vref input and switch over switch SW2.
 For f_c measurement: Set SW1 to the a position, set Vref to 0V, and switch over switch SW3.
 For I_{CC} measurement: Set the ENABLE input to the low level.

Power-on Reset

The application must perform a power-on reset operation when V_{CC2} power is first applied to this hybrid IC. Application circuit that used 2W1-2 phase excitation (microstepping operation) mode.

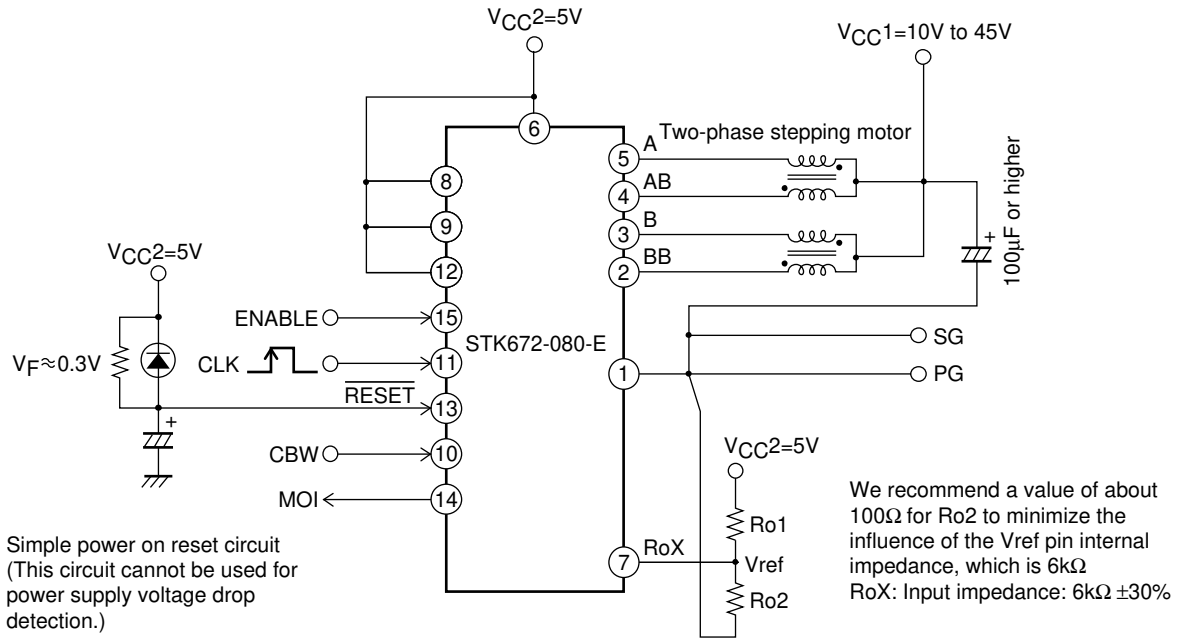

A13261

Setting the Motor Current

The motor current I_{OH} is set by the Vref voltage on the hybrid IC pin 7. The following formula gives the relationship between I_{OH} and Vref.

$$RoX = (Ro2 \times 6k\Omega) \div (Ro2 + 6k\Omega) \quad (1)$$

$$Vref = V_{CC2} \times RoX \div (Ro1 + RoX) \quad (2)$$

$$I_{OH} = \frac{1}{K} \times \frac{Vref}{R_s} \quad (3)$$

K: 4.7 (Voltage divider ratio),

R_s: 0.15Ω (This is the hybrid IC's internal current detection resistor. It has a tolerance of ±3%.)

Applications can use motor currents from the current (0.05 to 0.1A) set by the duty of the frequency set by the oscillator up to the limit of the allowable operating range, I_{OH} = 2.8A

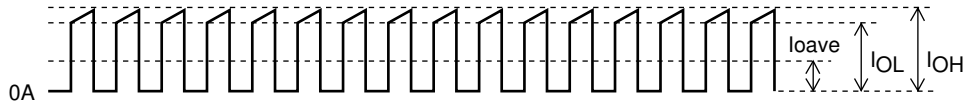

Motor current waveform

A13262

Function Table

M2	0	0	1	1	Phase switching clock edge timing
M1	0	1	0	1	
M3	0	1	0	1	
1	2 phase excitation	1-2 phase excitation	W1-2 phase excitation	2W1-2 phase excitation	Rising edge only
0	1-2 phase excitation	W1-2 phase excitation	2W1-2 phase excitation	4W1-2 phase excitation	Rising and falling edges

	Forward	Reverse
CWB	0	1

ENABLE	Motor current is cut off when low
RESET	Active low

Functional Description

External Excitation Chopper Drive Block Description

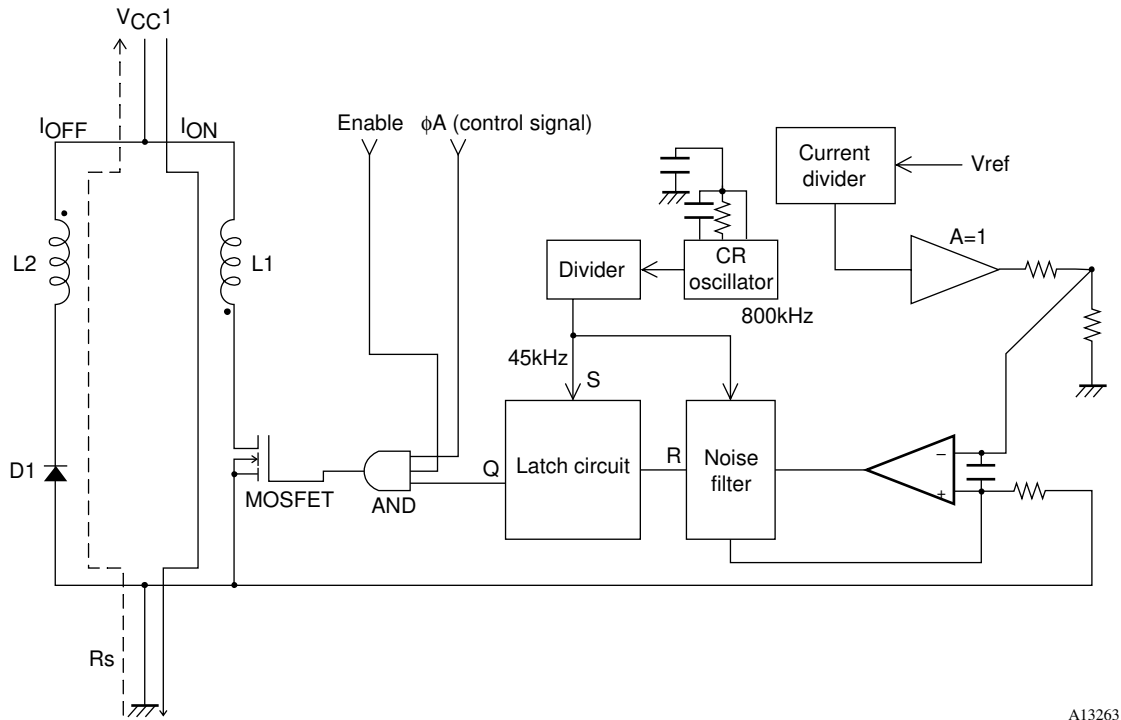

Driver Block Basic Circuit Structure

Since this hybrid IC adopts an external excitation method, no external oscillator circuit is required.

When a high level is input to ϕA in the basic driver block circuit shown in the figure and the MOSFET is turned on, the comparator + input will go low and the comparator output will go low. Since a set signal with the PWM period will be input, the Q output will go high, and the MOSFET will be turned on as its initial value.

The current I_{ON} flowing in the MOSFET passes through L1 and generates a potential difference in Rs. Then, when the Rs potential and the Vref potential become the same, the comparator output will invert, and the reset signal Q output will invert to the low level. Then, the MOSFET will be turned off and the energy stored in L1 will be induced in L2 and the current I_{OFF} will be regenerated to the power supply. This state will be maintained until the time when an input to the latch circuit set pin occurs.

In this manner, the Q output is turned off and on repeatedly by the reset and set signals, thus implementing constant current control. The resistor and capacitor on the comparator input are spike removal circuit elements and synchronize with the PWM frequency. Since this hybrid IC uses a fixed frequency due to the external excitation method and at the same time also adopts a synchronized PWM technique, it can suppress the noise associated with holding a position when the motor is locked.

Input Pin Functions

Pin No.	Symbol	Function	Pin circuit type
11	CLK	Phase switching clock	Built-in pull-up resistor CMOS Schmitt trigger input
10	CWB	Rotation direction setting (CW/CCW)	Built-in pull-up resistor CMOS Schmitt trigger input
15	ENABLE	Output cutoff	Built-in pull-up resistor CMOS Schmitt trigger input
8, 9, 12	M1, M2, M3	Excitation mode setting	Built-in pull-up resistor CMOS Schmitt trigger input
13	RESET	System reset	Built-in pull-up resistor CMOS Schmitt trigger input
7	Vref	Current setting	Input impedance 6kΩ (typ.) ±30%

Input Signal Functions and Timing

- CLK (phase switching clock)
 - 1) Input frequency range: DC to 50kHz
 - 2) Minimum pulse width: 10μs
 - 3) Duty: 40 to 60% (However, the minimum pulse width takes precedence when M3 is high.)
 - 4) Pin circuit type: Built-in pull-up resistor (20kΩ, typical) CMOS Schmitt trigger structure
 - 5) Built-in multi-stage noise rejection circuit
 - 6) Function:
 - When M3 is high or open: The phase excited (driven) is advanced one step on each CLK rising edge.
 - When M3 is low: The phase is advanced one step by both rising and falling edges, for a total of two steps per cycle.

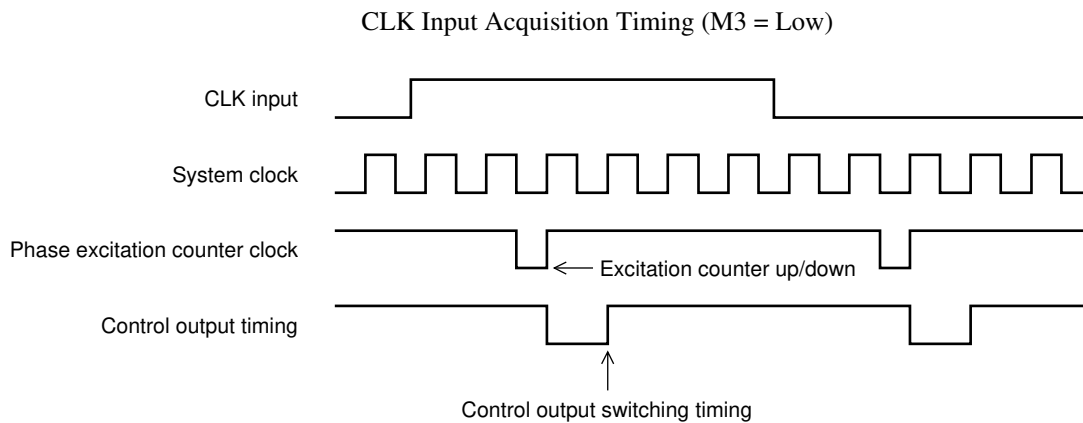

A13264

- CWB (Method for setting the rotation direction)
 - 1) Pin circuit type: Built-in pull-up resistor (20kΩ, typical) CMOS Schmitt trigger structure
 - 2) Function:
 - When CWB is low: The motor turns in the clockwise direction.
 - When CWB is high: The motor turns in the counterclockwise direction.
 - 3) Notes: When M3 is low, the CWB input must not be changed for about 6.25μs before or after a rising or falling edge on the CLK input.

- ENABLE (Controls the on/off state of the A, \bar{A} , B, and \bar{B} excitation drive outputs and selects either operating or hold as the internal state of this hybrid IC.)
 - 1) Pin circuit type: Built-in pull-up resistor (20kΩ, typical) CMOS Schmitt trigger structure
 - 2) Function:
 - When ENABLE is high or open: Normal operating state
 - When ENABLE is low: This hybrid IC goes to the hold state and excitation drive output (motor current) is forcibly turned off. In this mode, the hybrid IC system clock is stopped and no inputs other than the reset input have any effect on the hybrid IC state.

STK672-080-E

- M1, M2, and M3 (Excitation mode and CLK input edge timing selection)

1) Pin circuit type: Built-in pull-up resistor (20kΩ, typical) CMOS Schmitt trigger structure

2) Function:

M2	0	0	1	1	Phase switching clock edge timing
M1 M3	0	1	0	1	
1	2 phase excitation	1-2 phase excitation	W1-2 phase excitation	2W1-2 phase excitation	Rising edge only
0	1-2 phase excitation	W1-2 phase excitation	2W1-2 phase excitation	4W1-2 phase excitation	Rising and falling edges

3) Valid mode setting timing: Applications must not change the mode in the period 5μs before or after a CLK signal rising or falling edge.

Mode Setting Acquisition Timing

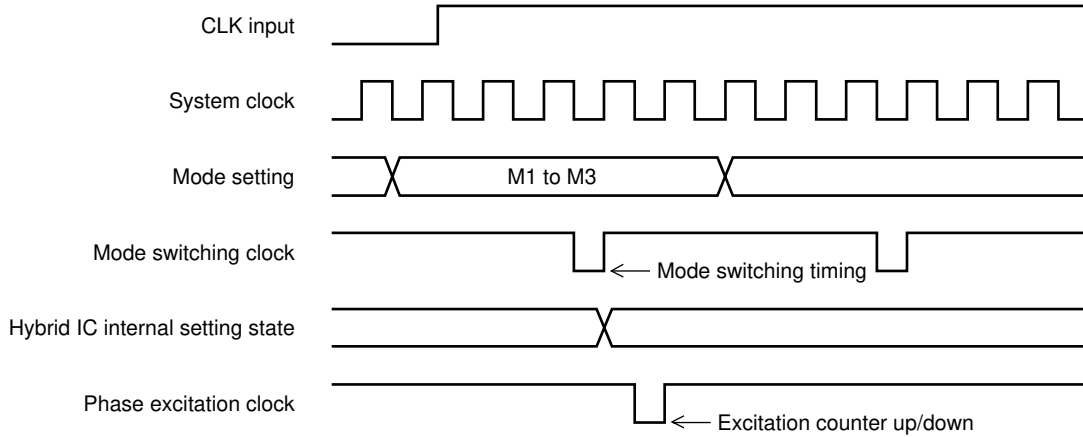

A13265

- $\overline{\text{RESET}}$ (Resets all parts of the system.)

1) Pin circuit type: Built-in pull-up resistor (20kΩ, typical) CMOS Schmitt trigger structure

2) Function:

- All circuit states are set to their initial values by setting the $\overline{\text{RESET}}$ pin low. (Note that the pulse width must be at least 10μs.)

At this time, the A and $\overline{\text{B}}$ phases are set to their origin, regardless of the excitation mode. The output current goes to about 71% after the reset is released.

3) Notes: When power is first applied to this hybrid IC, Vref must be established by applying a reset. Applications must apply a power on reset when the VCC2 power supply is first applied.

- Vref (Sets the current level used as the reference for constant-current detection.)

1) Pin circuit type: Analog input structure

2) Function:

- Constant-current control can be applied to the motor excitation current at 100% of the rated current by applying a voltage less than the control system power supply voltage VCC2 minus 2.5V.

- Applications can apply constant-current control proportional to the Vref voltage, with this value of 2.5V as the upper limit.

Output Pin Functions

Pin No.	Symbol	Function	Pin circuit type
14	MOI	Phase excitation origin monitor	Standard CMOS structure

Output Signal Functions and Timing

- A, $\overline{\text{A}}$, B, and $\overline{\text{B}}$ (Motor phase excitation outputs)

1) Function:

- In the 4 phase and 2 phase excitation modes, a 3.75μs (typical) interval is set up between the A and $\overline{\text{A}}$ and B and $\overline{\text{B}}$ output signal transition times.

Phase States During Excitation Switching

- Excitation phases before and after excitation mode switching <clockwise direction>

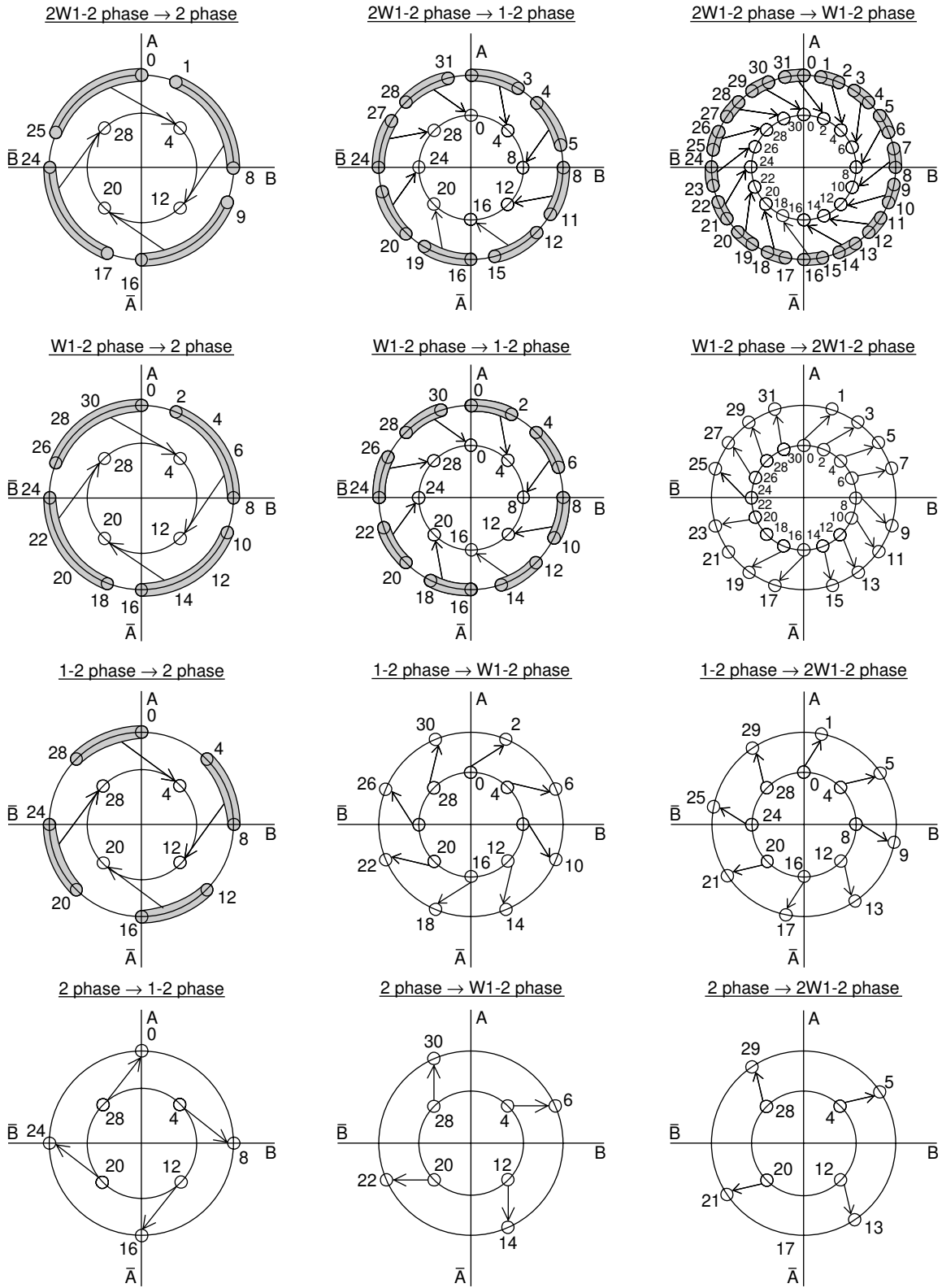

Excitation phase according to the first clock input pulse after changing the excitation mode setting (M1 and M2)
 Excitation phase immediately before setting the excitation mode

A13266

STK672-080-E

- Excitation phases before and after excitation mode switching <counterclockwise direction>

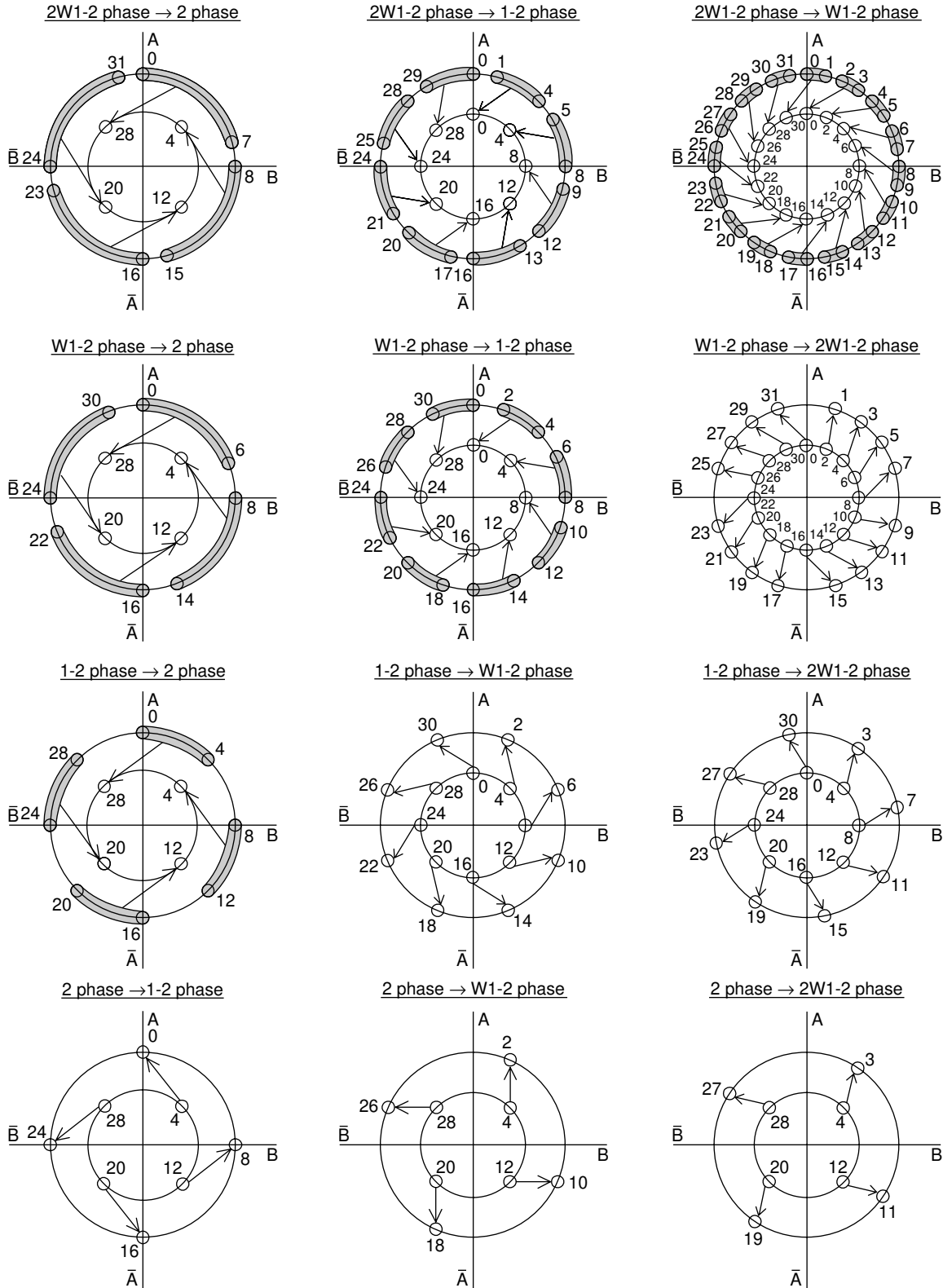

A13267

Excitation Time and Timing Charts

- CLK rising edge operation

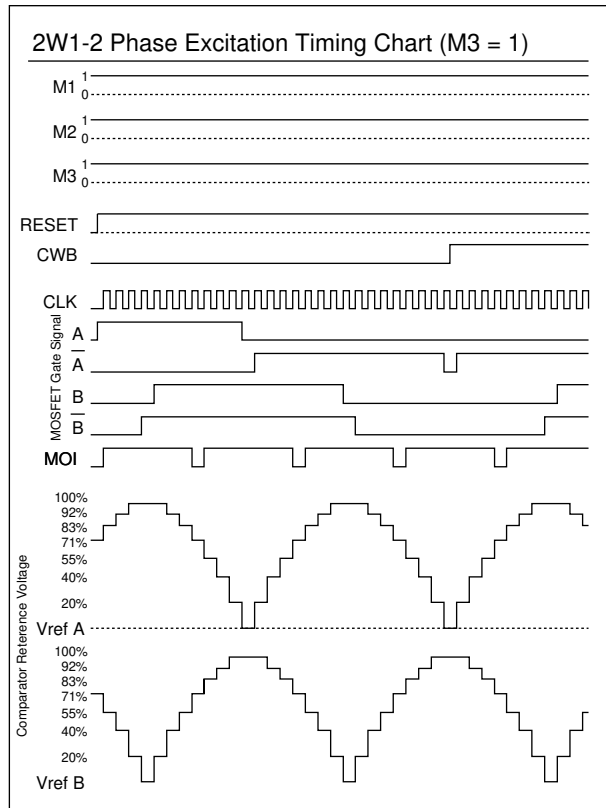
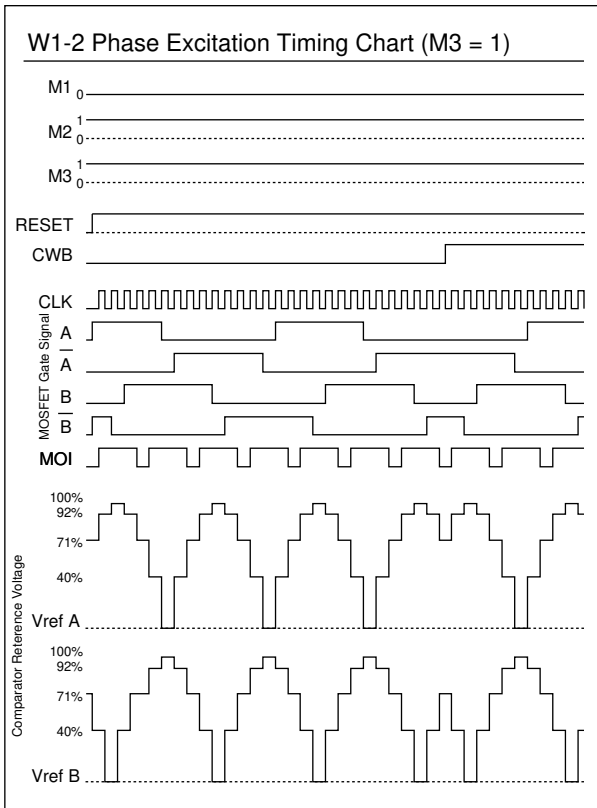
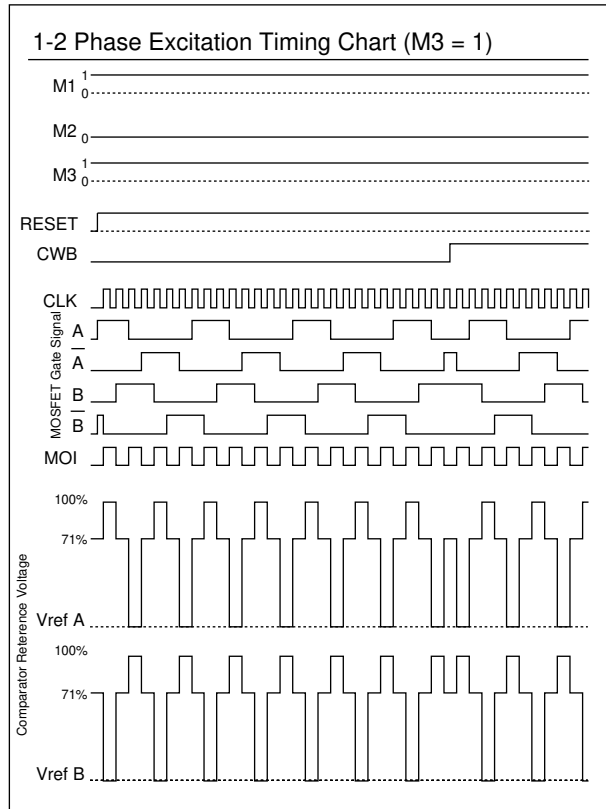
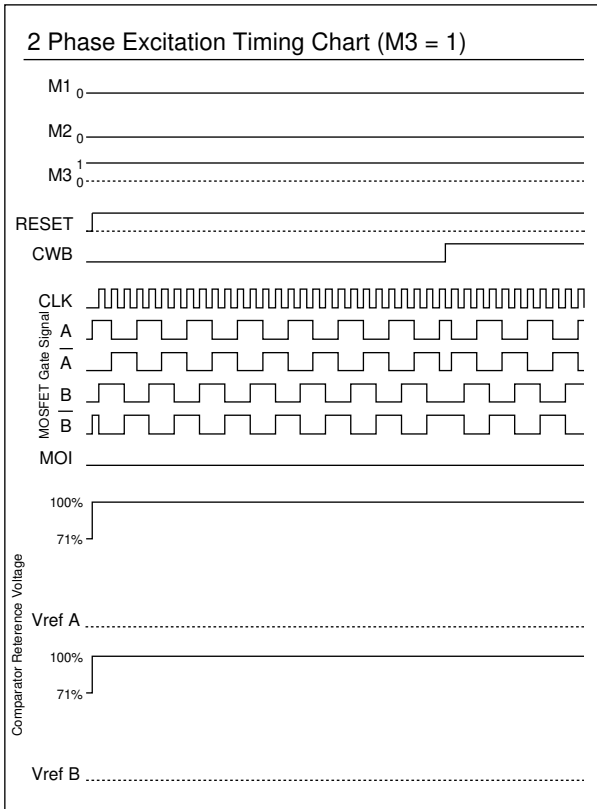

A13268

• CLK rising and falling edge operation

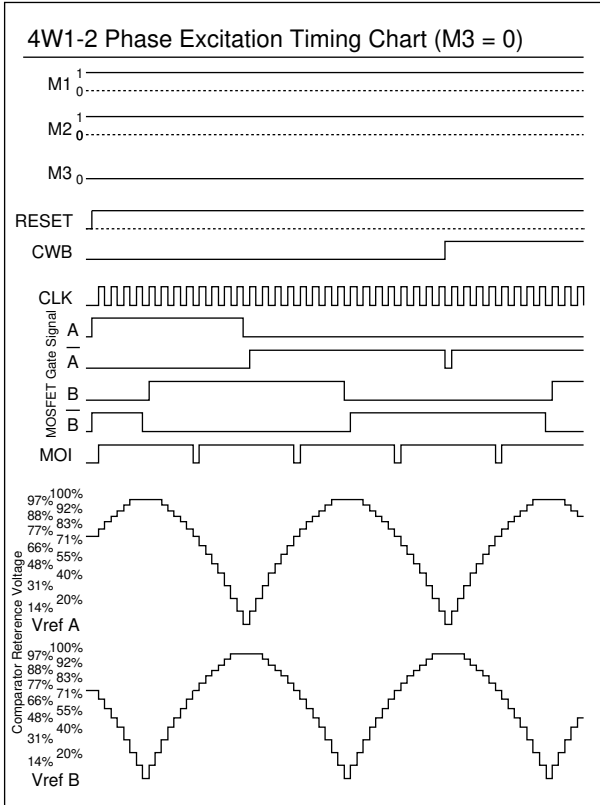
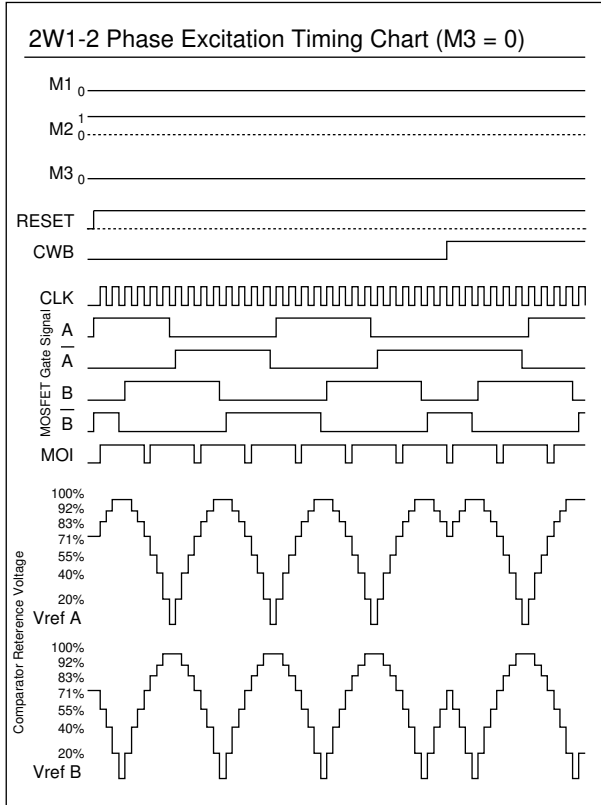
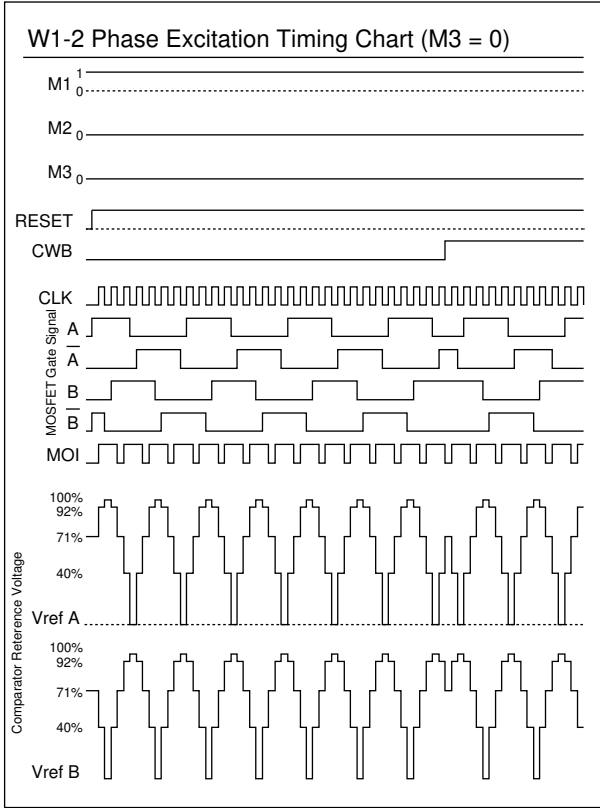
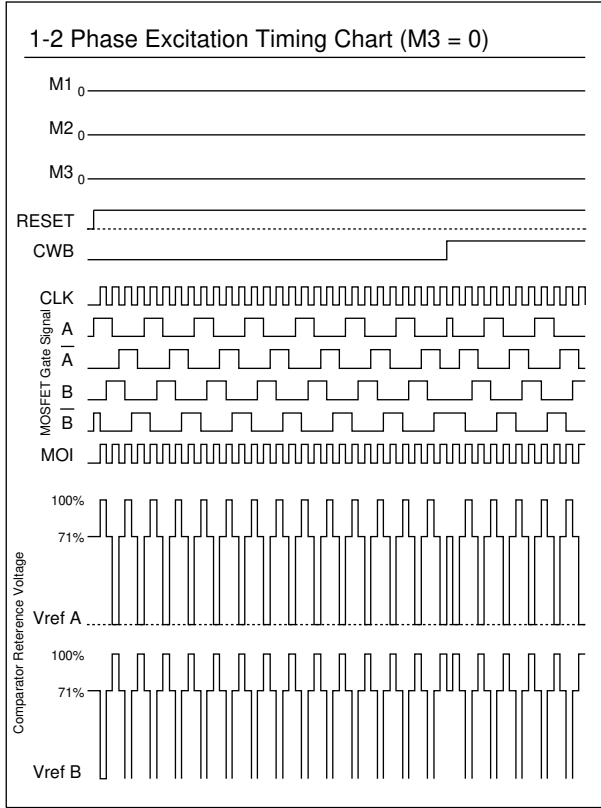

A13269

Thermal Design

<Hybrid IC Average Internal Power Loss Pd>

The main elements internal to this hybrid IC with large average power losses are the current control devices, the regenerative current diodes, and the current detection resistor. Since sine wave drive is used, the average power loss during microstepping drive can be approximated by applying a waveform factor of 0.64 to the square wave loss during 2 phase excitation.

The losses in the various excitation modes are as follows.

$$\text{2 phase excitation} \quad Pd_{2EX} = (V_{sat}+V_{df}) \cdot \frac{f_{clock}}{2} \cdot I_{OH} \cdot t_2 + \frac{I_{OH} \cdot f_{clock}}{2} \cdot (V_{sat} \cdot t_1 + V_{df} \cdot t_3)$$

$$\text{1-2 phase excitation} \quad Pd_{1-2EX} = 0.64 \cdot \left\{ (V_{sat}+V_{df}) \cdot \frac{f_{clock}}{4} \cdot I_{OH} \cdot t_2 + \frac{I_{OH} \cdot f_{clock}}{4} \cdot (V_{sat} \cdot t_1 + V_{df} \cdot t_3) \right\}$$

$$\text{W1-2 phase excitation} \quad Pd_{W1-2EX} = 0.64 \cdot \left\{ (V_{sat}+V_{df}) \cdot \frac{f_{clock}}{8} \cdot I_{OH} \cdot t_2 + \frac{I_{OH} \cdot f_{clock}}{8} \cdot (V_{sat} \cdot t_1 + V_{df} \cdot t_3) \right\}$$

$$\text{2W1-2 phase excitation} \quad Pd_{2W1-2EX} = 0.64 \cdot \left\{ (V_{sat}+V_{df}) \cdot \frac{f_{clock}}{16} \cdot I_{OH} \cdot t_2 + \frac{I_{OH} \cdot f_{clock}}{16} \cdot (V_{sat} \cdot t_1 + V_{df} \cdot t_3) \right\}$$

$$\text{4W1-2 phase excitation} \quad Pd_{4W1-2EX} = 0.64 \cdot \left\{ (V_{sat}+V_{df}) \cdot \frac{f_{clock}}{16} \cdot I_{OH} \cdot t_2 + \frac{I_{OH} \cdot f_{clock}}{16} \cdot (V_{sat} \cdot t_1 + V_{df} \cdot t_3) \right\}$$

Here, t1 and t3 can be determined from the same formulas for all excitation methods.

$$t_1 = \frac{-L}{R+0.35} \cdot \ln \left(1 - \frac{R+0.35}{V_{CC1}} \cdot I_{OH} \right) \qquad t_3 = \frac{-L}{R} \cdot \ln \left(\frac{V_{CC1}+0.35}{I_{OH} \cdot R + V_{CC1}+0.35} \right)$$

However, the formula for t2 differs with the excitation method.

$$\text{2 phase excitation} \quad t_2 = \frac{2}{f_{clock}} - (t_1+t_3) \qquad \text{1-2 phase excitation} \quad t_2 = \frac{3}{f_{clock}} - t_1$$

$$\text{W1-2 phase excitation} \quad t_2 = \frac{7}{f_{clock}} - t_1 \qquad \begin{matrix} \text{2W1-2 phase excitation} \\ \text{4W1-2 phase excitation} \end{matrix} \quad t_2 = \frac{15}{f_{clock}} - t_1$$

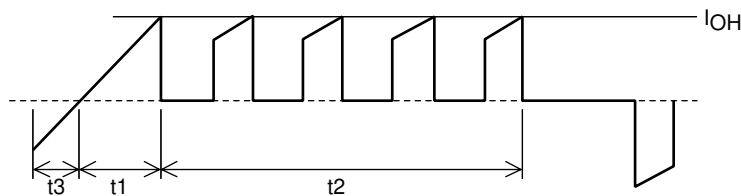

A13270

Motor Phase Current Model Figure (2 Phase Excitation)

f_{clock} : CLK input frequency (Hz)

V_{sat} : The voltage drop of the power MOSFET and the current detection resistor (V)

V_{df} : The voltage drop of the body diode and the current detection resistor (V)

I_{OH} : Phase current peak value (A)

t₁ : Phase current rise time (s)

V_{CC1} : Supply voltage applied to the motor (V)

t₂ : Constant-current operating time (s)

L : Motor inductance (H)

t₃ : Phase switching current regeneration time (s)

R : Motor winding resistance (Ω)

<Determining the Size of the Hybrid IC Heat Sink>

Determine θ_{c-a} for the heat sink from the average power loss determined in the previous item.

$T_{c \max}$: Hybrid IC substrate temperature ($^{\circ}\text{C}$)

T_a : Application internal temperature ($^{\circ}\text{C}$)

P_{dEX} : Hybrid IC internal average loss (W)

$$\theta_{c-a} = \frac{T_{c \max} - T_a}{P_{dEX}} \quad [^{\circ}\text{C}/\text{W}]$$

Determine θ_{c-a} from the above formula and then size S (in cm^2) of the heat sink from the graphs shown below.

The ambient temperature of the device will vary greatly according to the air flow conditions within the application.

Therefore, always verify that the size of the heat sink is adequate to assure that the Hybrid IC back surface (the aluminum plate side) will never exceed a $T_{c \max}$ of 105°C , whatever the operating conditions are.

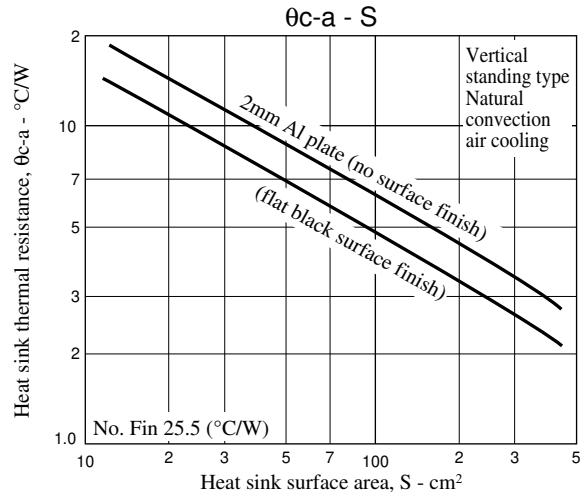
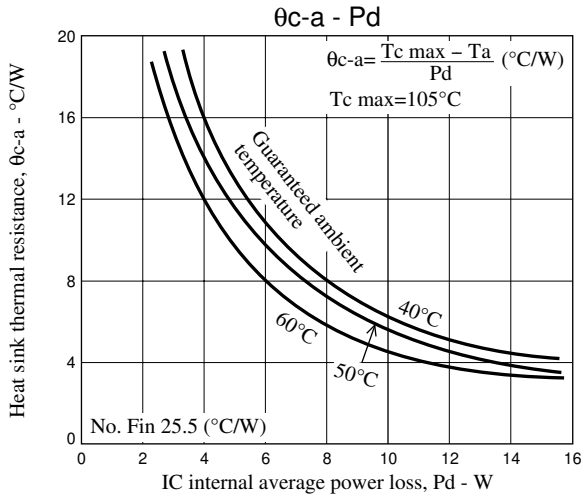

Next we determine the usage conditions with no heat sink by determining the allowable hybrid IC internal average loss from the thermal resistance of the hybrid IC substrate, namely $25.5^{\circ}\text{C}/\text{W}$.

For a $T_{c \max}$ of 105°C at an ambient temperature of 50°C $P_{dEX} = \frac{105 - 50}{25.5} = 2.15\text{W}$

For a $T_{c \max}$ of 105°C at an ambient temperature of 40°C $P_{dEX} = \frac{105 - 40}{25.5} = 2.54\text{W}$

This hybrid IC can be used with no heat sink as long as it is used at operating conditions below the losses listed above. (See $\Delta T_c - P_d$ curve in the graph on page 17.)

<Hybrid IC internal power element (MOSFET) junction temperature calculation>

The junction temperature, T_j , of each device can be determined from the loss P_{ds} in each transistor and the thermal resistance θ_{j-c} .

$$T_j = T_c + \theta_{j-c} \times P_{ds} \quad (^{\circ}\text{C})$$

Here, we determine P_{ds} , the loss for each transistor, by determining P_{dEX} in each excitation mode.

$$P_{ds} = P_{dEX}/4$$

The steady-state thermal resistance θ_{j-c} of a power MOSFET is $15.6^{\circ}\text{C}/\text{W}$.

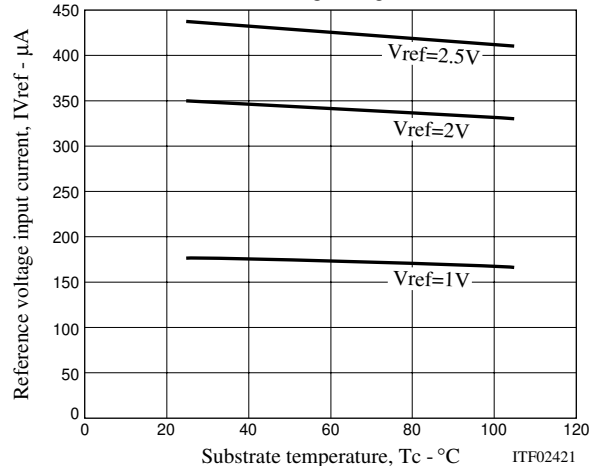
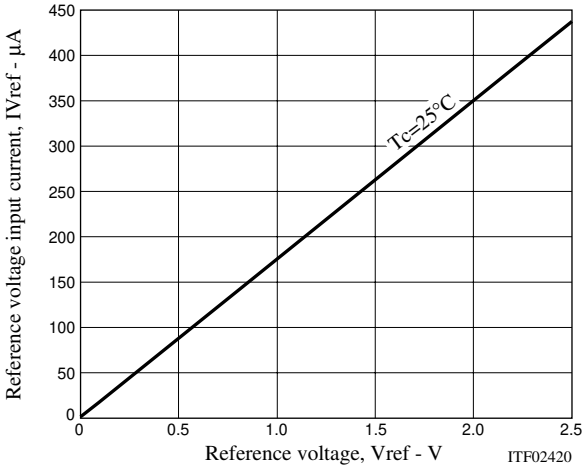
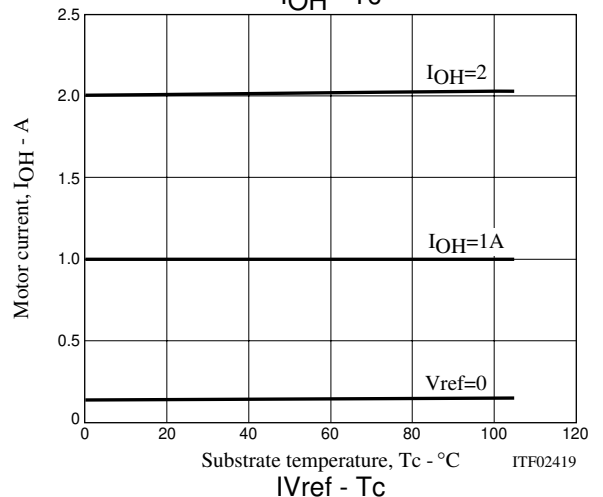
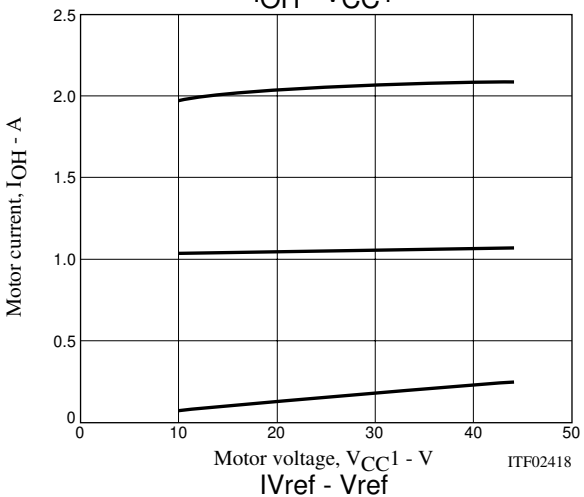
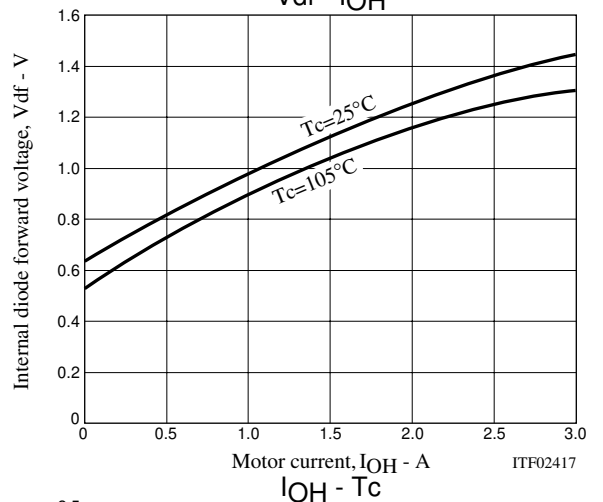
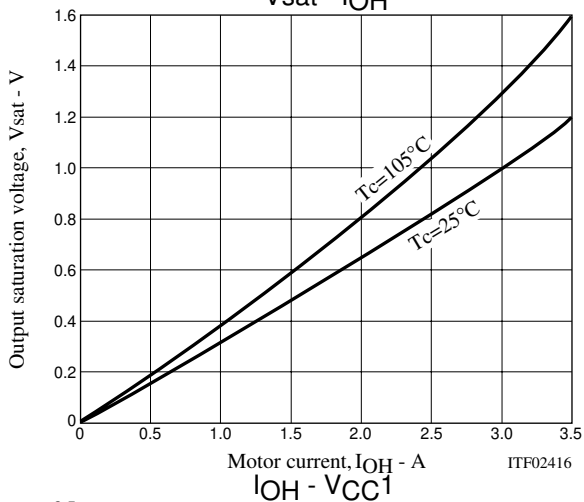
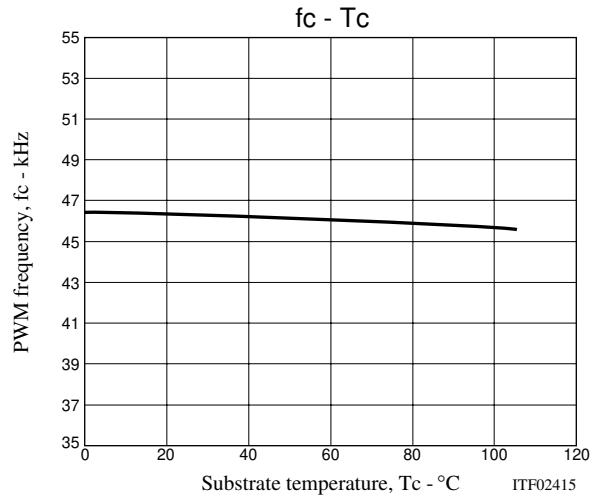
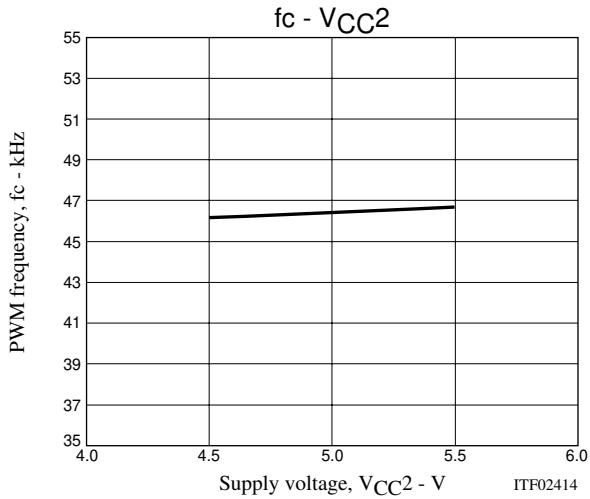

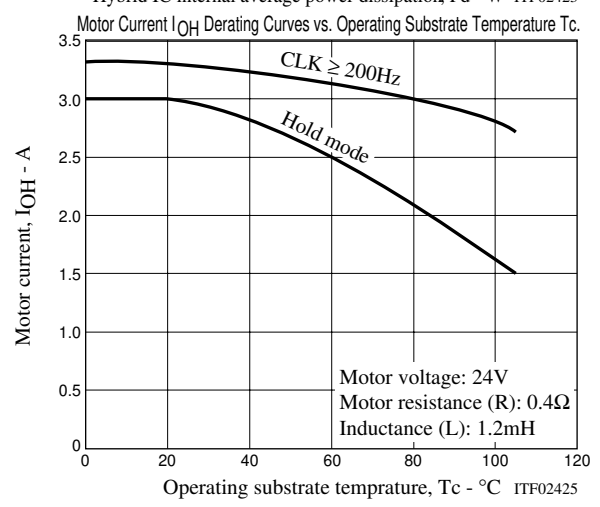
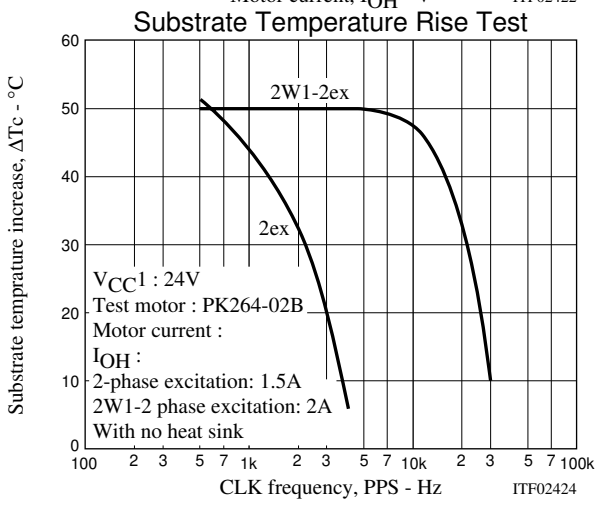
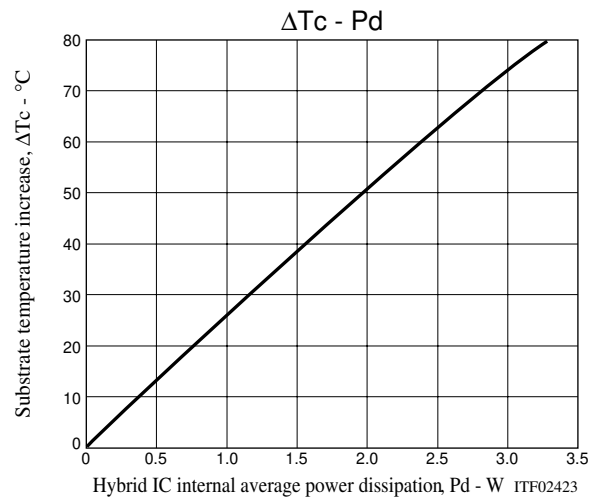
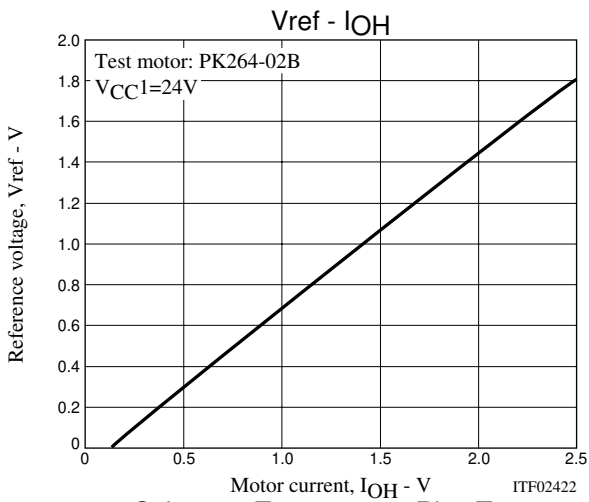

Notes

- The current ranges shown above apply when the output voltage is not in the avalanche range.
- The operating substrate temperature Tc values shown above are measured during motor operation. Since Tc varies with the ambient temperature Ta, the value of IOH, and whether IOH is continuous or intermittent, it must be measured in an actual operating system.

ON Semiconductor and the ON logo are registered trademarks of Semiconductor Components Industries, LLC (SCILLC). SCILLC owns the rights to a number of patents, trademarks, copyrights, trade secrets, and other intellectual property. A listing of SCILLC's product/patent coverage may be accessed at www.onsemi.com/site/pdf/Patent-Marking.pdf. SCILLC reserves the right to make changes without further notice to any products herein. SCILLC makes no warranty, representation or guarantee regarding the suitability of its products for any particular purpose, nor does SCILLC assume any liability arising out of the application or use of any product or circuit, and specifically disclaims any and all liability, including without limitation special, consequential or incidental damages. "Typical" parameters which may be provided in SCILLC data sheets and/or specifications can and do vary in different applications and actual performance may vary over time. All operating parameters, including "Typicals" must be validated for each customer application by customer's technical experts. SCILLC does not convey any license under its patent rights nor the rights of others. SCILLC products are not designed, intended, or authorized for use as components in systems intended for surgical implant into the body, or other applications intended to support or sustain life, or for any other application in which the failure of the SCILLC product could create a situation where personal injury or death may occur. Should Buyer purchase or use SCILLC products for any such unintended or unauthorized application, Buyer shall indemnify and hold SCILLC and its officers, employees, subsidiaries, affiliates, and distributors harmless against all claims, costs, damages, and expenses, and reasonable attorney fees arising out of, directly or indirectly, any claim of personal injury or death associated with such unintended or unauthorized use, even if such claim alleges that SCILLC was negligent regarding the design or manufacture of the part. SCILLC is an Equal Opportunity/Affirmative Action Employer. This literature is subject to all applicable copyright laws and is not for resale in any manner.