

PCB LAYOUT: COMPONENT SIDE
RECOMMEND PCB THICKNESS: .062/1.57

CKTS	A	B	C
02	.262 6.65	NA	.236 6.00
04	.380 9.65	.118 3.00	.354 9.00
06	.498 12.65	.236 6.00	.472 12.00
08	.616 15.65	.354 9.00	.591 15.00
10	.734 18.65	.472 12.00	.709 18.00
12	.852 21.65	.591 15.00	.827 21.00
14	.970 24.65	.709 18.00	.945 24.00
16	1.088 27.65	.827 21.00	1.063 27.00
18	1.206 30.65	.945 24.00	1.181 30.00
20	1.325 33.65	1.063 27.00	1.299 33.00
22	1.443 36.65	1.181 30.00	1.417 36.00
24	1.561 39.65	1.299 33.00	1.535 39.00

NOTE: (2) POLARIZATION PEGS ARE SHOWN.
HOWEVER, ASSEMBLIES MAY BE MANUFACTURED
WITH (1) PEG ONLY.

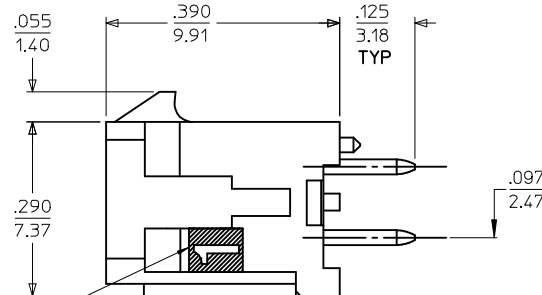
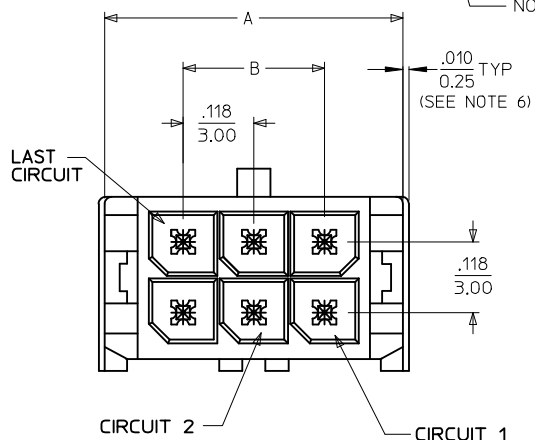

CIRCUIT "*" IDENTIFIED ON THIS SURFACE
(APPROX. LOCATION SHOWN FOR REF.)

NOTES:

- HOUSING MATERIAL: GLASS FILLED LIQUID CRYSTAL POLYMER, UL94V-0, COLOR-BLACK
TERMINAL MATERIAL: BRASS ALLOY
- FINISH: A = .000060/(0.00152) MIN. REFLOWED MATTE TIN OVER .000050/(0.00127) MIN. NICKEL PLATE. (FINISH IS BRIGHT IN APPEARANCE, THICKNESS AS APPLIED PRIOR TO REFLOW)
B = .000015/(0.00038) MIN. SELECT GOLD IN CONTACT AREA, .000100/(0.00254) MIN. SELECT MATTE TIN ON SOLDER TAILS, BOTH OVER .000050/(0.00127) MIN. NICKEL PLATE.
C = .000030/(0.00076) MIN. SELECT GOLD IN CONTACT AREA, .000100/(0.00254) MIN. SELECT MATTE TIN ON SOLDER TAILS, BOTH OVER .000050/(0.00127) MIN. NICKEL PLATE.
D = .000100/(0.00254) MIN. MATTE TIN OVER .000050/(0.00127) MIN. NICKEL PLATE.
- PRODUCT SPECIFICATION: PS-43045
- TRAY PACKAGED: SEE MOLEX DRAWING PK-70873-0314
- MATES WITH MICRO FIT (3,0) RECEPTACLE SERIES 43025
- CIRCUIT SIZES 2-6: "D" IS .265/6.74 FOR .010/0.25 STEP
CIRCUIT SIZES 8-24: "D" IS .063/1.60 FOR .010/0.25 STEP.
- THIS PART CONFORMS TO CLASS B REQUIREMENTS OF COSMETIC SPECIFICATION PS-45499-002.

	FINISH A	FINISH B	FINISH C	FINISH D
CKTS	MATERIAL NO:	MATERIAL NO:	MATERIAL NO:	MATERIAL NO:
02	43045-0227	43045-0228	43045-0229	43045-0298
04	43045-0427	43045-0428	43045-0429	43045-0498
06	43045-0627	43045-0628	43045-0629	43045-0698
08	43045-0827	43045-0828	43045-0829	43045-0898
10	43045-1027	43045-1028	43045-1029	43045-1098
12	43045-1227	43045-1228	43045-1229	43045-1298
14	43045-1427	43045-1428	43045-1429	43045-1498
16	43045-1627	43045-1628	43045-1629	43045-1698
18	43045-1827	43045-1828	43045-1829	43045-1898
20	43045-2027	43045-2028	43045-2029	43045-2098
22	43045-2227	43045-2228	43045-2229	43045-2298
24	43045-2427	43045-2428	43045-2429	43045-2498

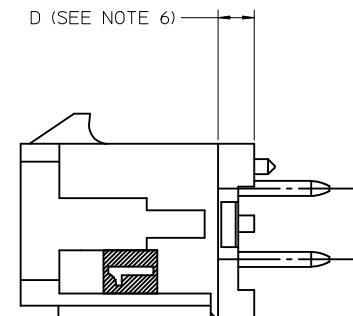

REVISE FINISH A EC NO: UCP2016-0464 DRWIN:JDOX 2015/08/20 CHKD:SSOUSEK 2015/08/20 APPR:FSMLTH 2015/11/19	QUALITY SYMBOLS	GENERAL TOLERANCES (UNLESS SPECIFIED)	DIMENSION STYLE IN/MM	SCALE ---	DESIGN UNITS METRIC	THIRD ANGLE PROJECTION
	▽=0	mm INCH	DRAWN BY DATE SAMIEC 2000/03/15	TITLE MICRO FIT (3.0) DUAL ROW VERTICAL THRU HOLE HEADER ASS'Y	molex DOCUMENT NO. SD-43045-010 SHEET NO. 1 OF 1	THIS DRAWING CONTAINS INFORMATION THAT IS PROPRIETARY TO MOLEX INCORPORATED AND SHOULD NOT BE USED WITHOUT WRITTEN PERMISSION
	▽=0	4 PLACES ± --- ± ---	CHECKED BY DATE MUELLER 2000/03/15	MATERIAL NO. SEE CHART		
	▽=0	3 PLACES ± --- ± .010	APPROVED BY DATE EDGELY 2000/03/15			
▽=0	2 PLACES ± 0.25 ± .014	ANGULAR ±1/2°	SIZE C			
G2	1 PLACE ± 0.36 ± ---	DRAFT WHERE APPLICABLE MUST REMAIN WITHIN DIMENSIONS				

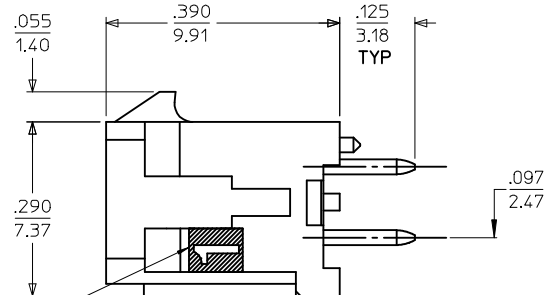
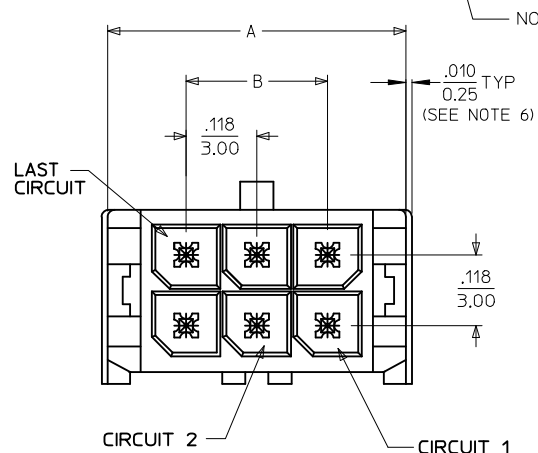
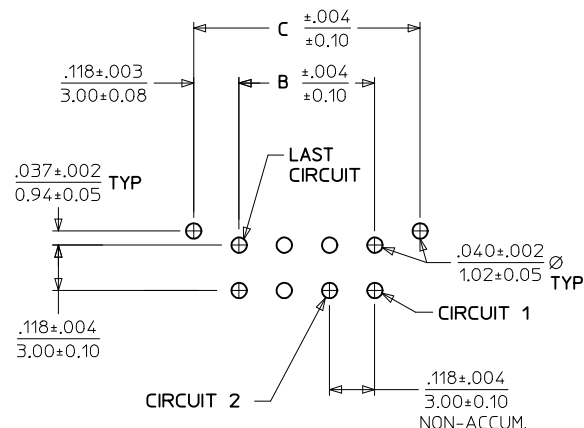
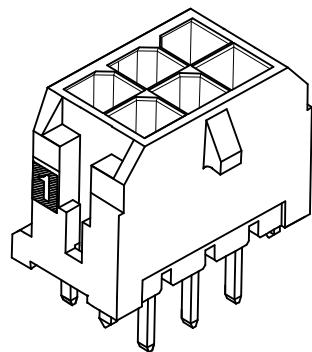
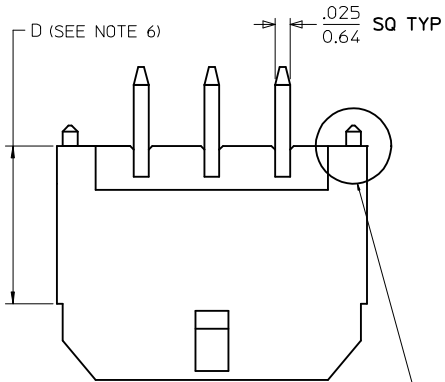

PCB LAYOUT: COMPONENT SIDE
RECOMMEND PCB THICKNESS: .062/1.57

CKTS	A	B	C
02	.262 6.65	NA	.236 6.00
04	.380 9.65	.118 3.00	.354 9.00
06	.498 12.65	.236 6.00	.472 12.00
08	.616 15.65	.354 9.00	.591 15.00
10	.734 18.65	.472 12.00	.709 18.00
12	.852 21.65	.591 15.00	.827 21.00
14	.970 24.65	.709 18.00	.945 24.00
16	1.088 27.65	.827 21.00	1.063 27.00
18	1.206 30.65	.945 24.00	1.181 30.00
20	1.325 33.65	1.063 27.00	1.299 33.00
22	1.443 36.65	1.181 30.00	1.417 36.00
24	1.561 39.65	1.299 33.00	1.535 39.00

NOTE: (2) POLARIZATION PEGS ARE SHOWN.
HOWEVER, ASSEMBLIES MAY BE MANUFACTURED
WITH (1) PEG ONLY.

CIRCUIT "*" IDENTIFIED ON THIS SURFACE
(APPROX. LOCATION SHOWN FOR REF.)

NOTES:

- HOUSING MATERIAL: GLASS FILLED LIQUID CRYSTAL POLYMER, UL94V-0, COLOR-BLACK
TERMINAL MATERIAL: BRASS ALLOY
- FINISH: A = .000060/(0.00152) MIN. REFLOWED MATTE TIN OVER
.000050/(0.00127) MIN. NICKEL PLATE.
(FINISH IS BRIGHT IN APPEARANCE, THICKNESS AS
APPLIED PRIOR TO REFLOW)
B = .000015/(0.00038) MIN. SELECT GOLD IN CONTACT AREA,
.000100/(0.00254) MIN. SELECT MATTE TIN ON SOLDER TAILS,
BOTH OVER .000050/(0.00127) MIN. NICKEL PLATE.
C = .000030/(0.00076) MIN. SELECT GOLD IN CONTACT AREA,
.000100/(0.00254) MIN. SELECT MATTE TIN ON SOLDER TAILS,
BOTH OVER .000050/(0.00127) MIN. NICKEL PLATE.
D = .000100/(0.00254) MIN. MATTE TIN OVER
.000050/(0.00127) MIN. NICKEL PLATE.
- PRODUCT SPECIFICATION: PS-43045
- TRAY PACKAGED: SEE MOLEX DRAWING PK-70873-0314
- MATES WITH MICRO FIT (3,0) RECEPTACLE SERIES 43025
- CIRCUIT SIZES 2-6: "D" IS .265/6.74 FOR .010/0.25 STEP
CIRCUIT SIZES 8-24: "D" IS .063/1.60 FOR .010/0.25 STEP.
- THIS PART CONFORMS TO CLASS B REQUIREMENTS OF COSMETIC SPECIFICATION
PS-45499-002.

	FINISH A	FINISH B	FINISH C	FINISH D
CKTS	MATERIAL NO:	MATERIAL NO:	MATERIAL NO:	MATERIAL NO:
02	43045-0227	43045-0228	43045-0229	43045-0298
04	43045-0427	43045-0428	43045-0429	43045-0498
06	43045-0627	43045-0628	43045-0629	43045-0698
08	43045-0827	43045-0828	43045-0829	43045-0898
10	43045-1027	43045-1028	43045-1029	43045-1098
12	43045-1227	43045-1228	43045-1229	43045-1298
14	43045-1427	43045-1428	43045-1429	43045-1498
16	43045-1627	43045-1628	43045-1629	43045-1698
18	43045-1827	43045-1828	43045-1829	43045-1898
20	43045-2027	43045-2028	43045-2029	43045-2098
22	43045-2227	43045-2228	43045-2229	43045-2298
24	43045-2427	43045-2428	43045-2429	43045-2498

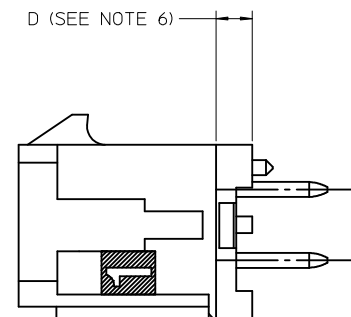

REVISE FINISH A EC NO: UCP2016-0464 DRWIN:JDOX CHKD:SSOUSEK APPR:FSMLTH 2015/08/20 2015/08/20 2015/11/19	QUALITY SYMBOLS ∇=0 ∇=0 ∇=0	GENERAL TOLERANCES (UNLESS SPECIFIED)	DIMENSION STYLE IN/MM	SCALE ---	DESIGN UNITS METRIC	THIRD ANGLE PROJECTION																		
		<table border="1"> <tr> <th></th> <th>mm</th> <th>INCH</th> </tr> <tr> <td>4 PLACES ±</td> <td>---</td> <td>---</td> </tr> <tr> <td>3 PLACES ±</td> <td>---</td> <td>±.010</td> </tr> <tr> <td>2 PLACES ±</td> <td>0.25</td> <td>±.014</td> </tr> <tr> <td>1 PLACE ±</td> <td>0.36</td> <td>---</td> </tr> <tr> <td>0 PLACE ±</td> <td>---</td> <td>---</td> </tr> </table>		mm	INCH	4 PLACES ±	---	---	3 PLACES ±	---	±.010	2 PLACES ±	0.25	±.014	1 PLACE ±	0.36	---	0 PLACE ±	---	---	DRAWN BY: SAMIEC DATE: 2000/03/15 CHECKED BY: MUELLER DATE: 2000/03/15 APPROVED BY: EDGELY DATE: 2000/03/15	TITLE: MICRO FIT (3,0) DUAL ROW VERTICAL THRU HOLE HEADER ASS'Y molex		
			mm	INCH																				
		4 PLACES ±	---	---																				
3 PLACES ±	---	±.010																						
2 PLACES ±	0.25	±.014																						
1 PLACE ±	0.36	---																						
0 PLACE ±	---	---																						
ANGULAR ±1/2° DRAFT WHERE APPLICABLE MUST REMAIN WITHIN DIMENSIONS		MATERIAL NO. SEE CHART		DOCUMENT NO. SD-43045-010		SHEET NO. 1 OF 1																		
THIS DRAWING CONTAINS INFORMATION THAT IS PROPRIETARY TO MOLEX INCORPORATED AND SHOULD NOT BE USED WITHOUT WRITTEN PERMISSION																								