

PART NUMBER	MOUNT OPTION	PLATING SEE NOTE 2
172648-0103	PEG	TIN
172648-1103	PEG	GOLD

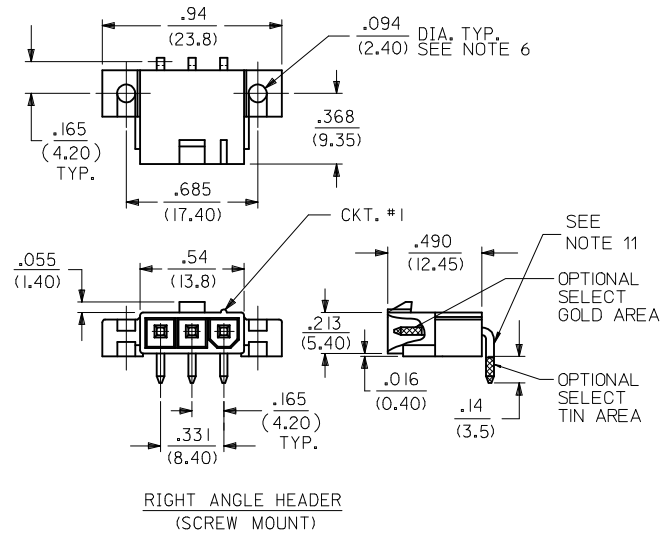

RIGHT ANGLE HEADER
(SCREW MOUNT)

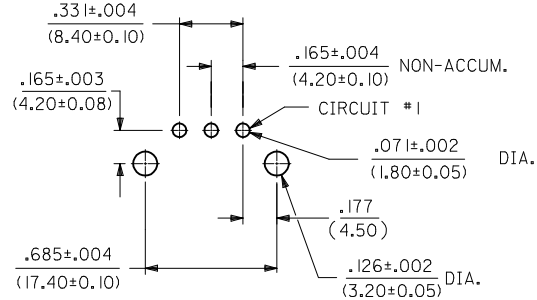

RECOMMENDED HOLE LAYOUT FOR
.070/(1.78) MAX. THICK P.C. BOARD
VIEWED FROM COMPONENT SIDE

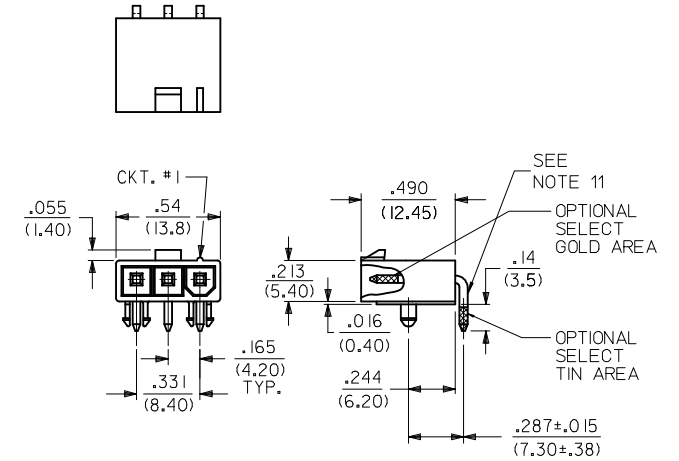

RIGHT ANGLE HEADER
(PEG MOUNT)

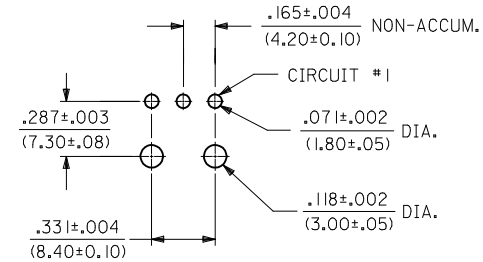

RECOMMENDED HOLE LAYOUT FOR
.070/(1.78) MAX. THICK P.C. BOARD
VIEWED FROM COMPONENT SIDE

NOTES:

- MATERIAL:
HOUSING:
UNFILLED NYLON, UL94V-2, IEC 60335-1
5TH EDITION GLOW WIRE CAPABLE, COLOR - BLACK.
TERMINAL MATERIAL: BRASS ALLOY
- TERMINAL PLATING:
TIN = .000100/(0.00254) MIN. MATTE TIN OVER
.000050/(0.00127) MIN. NICKEL OVERALL.
GOLD = .000030/(0.00076) MIN. SELECT GOLD, .000100/(0.00254) MIN. SELECT
MATTE TIN OVER .000050/(0.00127) MIN. NICKEL OVERALL
- PRODUCT SPECIFICATION: PS-5556-001.
- PACKAGING SPECIFICATION: PK-5569-002.
- PART MATES WITH MOLEX RECEPTACLE 46994 SERIES.
- PART IS DESIGNED FOR USE WITH #4 OR M3 SELF TAPPING SCREWS.
- DISCOLORATION IN THE BANDOLIER CARRIER AREA OF THE PIN IS
INHERENT TO THE PLATING PROCESS AND IS DUE TO THE MASKING
EFFECT OF THE CARRIER. THIS DISCOLORATION IS IN A NON-FUNCTIONAL
AREA OF THE PIN AND WILL NOT AFFECT THE PERFORMANCE OF THE
HEADER ASSEMBLY.
- CONNECTORS ARE NOT TO BE MATED AND UNMATED WHILE CIRCUITS ARE LIVE.
- PARTS ARE NOT DESIGNED FOR CURRENT SHARING.
- PART CONFORMS TO CLASS "B" REQUIREMENTS OF COSMETIC
SPECIFICATION PS-45499-002. WITH THE EXCEPTION OF DISCOLORATION,
FLASH AND SINK MEET CLASS "C" REQUIREMENTS.
- FORMING MARKS ON PINS ARE ACCEPTABLE

172648 - * * 03

PLATING
SEE NOTE 2
0 = TIN
1 = GOLD

ASSEMBLY TYPE
1 = SINGLE ROW W/PEGS, POSITIVE LOCK
2 = SINGLE ROW W/SCREW MOUNT, POSITIVE LOCK

CREATE DRAWING EC NO: UCP2013-4208 DRAWN: NGUYEN 2014/04/11 CHKD: JBELL 2014/04/11 APPR: FSMITH 2014/05/16	QUALITY SYMBOLS ▽=0 ▽=0 ▽=0	GENERAL TOLERANCES (UNLESS SPECIFIED)		DIMENSION STYLE IN/MM		SCALE 2:1	DESIGN UNITS METRIC	THIRD ANGLE PROJECTION
		DRAWN BY DATE NGUYEN 2014/04/11		CHECKED BY DATE JBELL 2014/04/11		TITLE 3 CKT GLOW WIRE HEADER MINI-FIT JR. SERIES (SINGLE ROW)		
DRAFT WHERE APPLICABLE MUST REMAIN WITHIN DIMENSIONS		ANGULAR ± 5 °		APPROVED BY DATE FSMITH 2014/05/16		DOCUMENT NO. SD-172648-0001		
SIZE C		THIS DRAWING CONTAINS INFORMATION THAT IS PROPRIETARY TO MOLEX INCORPORATED AND SHOULD NOT BE USED WITHOUT WRITTEN PERMISSION						
REV		MATERIAL NO.		SEE CHART		SHEET NO. 1 OF 1		

PART NUMBER	MOUNT OPTION	PLATING SEE NOTE 2
172648-0103	PEG	TIN
172648-1103	PEG	GOLD

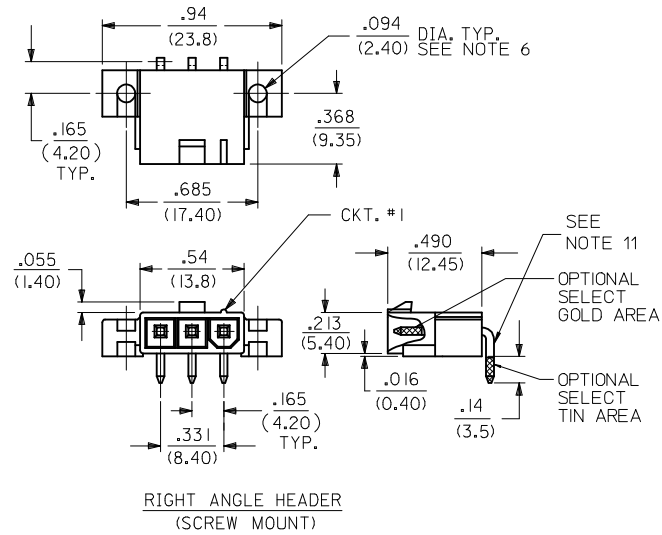

RIGHT ANGLE HEADER
(SCREW MOUNT)

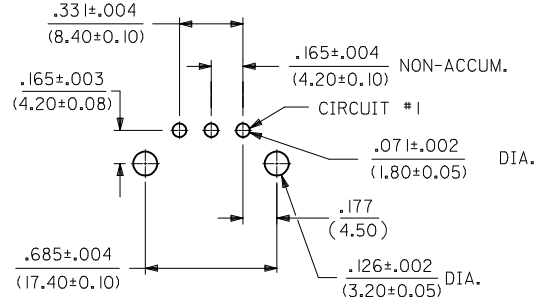

RECOMMENDED HOLE LAYOUT FOR
.070/(1.78) MAX. THICK P.C. BOARD
VIEWED FROM COMPONENT SIDE

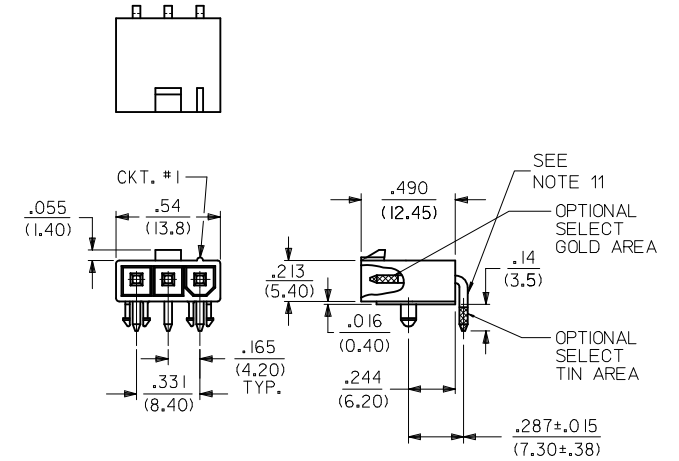

RIGHT ANGLE HEADER
(PEG MOUNT)

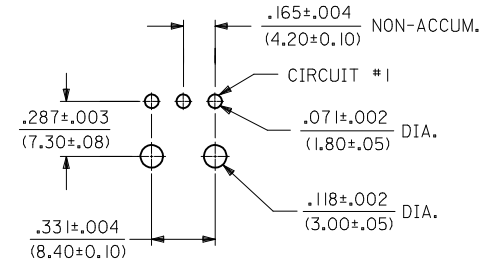

RECOMMENDED HOLE LAYOUT FOR
.070/(1.78) MAX. THICK P.C. BOARD
VIEWED FROM COMPONENT SIDE

NOTES:

- MATERIAL:
HOUSING:
UNFILLED NYLON, UL94V-2, IEC 60335-1
5TH EDITION GLOW WIRE CAPABLE, COLOR - BLACK.
TERMINAL MATERIAL: BRASS ALLOY
- TERMINAL PLATING:
TIN = .000100/(0.00254) MIN. MATTE TIN OVER
.000050/(0.00127) MIN. NICKEL OVERALL.
GOLD = .000030/(0.00076) MIN. SELECT GOLD, .000100/(0.00254) MIN. SELECT
MATTE TIN OVER .000050/(0.00127) MIN. NICKEL OVERALL
- PRODUCT SPECIFICATION: PS-5556-001.
- PACKAGING SPECIFICATION: PK-5569-002.
- PART MATES WITH MOLEX RECEPTACLE 46994 SERIES.
- PART IS DESIGNED FOR USE WITH #4 OR M3 SELF TAPPING SCREWS.
- DISCOLORATION IN THE BANDOLIER CARRIER AREA OF THE PIN IS
INHERENT TO THE PLATING PROCESS AND IS DUE TO THE MASKING
EFFECT OF THE CARRIER. THIS DISCOLORATION IS IN A NON-FUNCTIONAL
AREA OF THE PIN AND WILL NOT AFFECT THE PERFORMANCE OF THE
HEADER ASSEMBLY.
- CONNECTORS ARE NOT TO BE MATED AND UNMATED WHILE CIRCUITS ARE LIVE.
- PARTS ARE NOT DESIGNED FOR CURRENT SHARING.
- PART CONFORMS TO CLASS "B" REQUIREMENTS OF COSMETIC
SPECIFICATION PS-45499-002. WITH THE EXCEPTION OF DISCOLORATION,
FLASH AND SINK MEET CLASS "C" REQUIREMENTS.
- FORMING MARKS ON PINS ARE ACCEPTABLE

172648 - * * 03

PLATING
SEE NOTE 2
0 = TIN
1 = GOLD

ASSEMBLY TYPE
1 = SINGLE ROW W/PEGS, POSITIVE LOCK
2 = SINGLE ROW W/SCREW MOUNT, POSITIVE LOCK

CREATE DRAWING EC NO: UCP2013-4208 DRAWN: NGUYEN 2014/04/11 CHKD: JBELL 2014/04/11 APPR: FSMITH 2014/05/16	QUALITY SYMBOLS ▽=0 ▽=0 ▽=0	GENERAL TOLERANCES (UNLESS SPECIFIED)		DIMENSION STYLE IN/MM		SCALE 2:1	DESIGN UNITS METRIC	THIRD ANGLE PROJECTION	
		4 PLACES ± --- ± ---	3 PLACES ± --- ± .010	2 PLACES ± 0.25 ± .015	1 PLACE ± 0.38 ± ---	0 PLACE ± --- ± ---	ANGULAR ± 5 °	DRAWN BY DATE NGUYEN 2014/04/11 CHECKED BY DATE JBELL 2014/04/11 APPROVED BY DATE FSMITH 2014/05/16	
DRAFT WHERE APPLICABLE MUST REMAIN WITHIN DIMENSIONS		MATERIAL NO. SEE CHART		DOCUMENT NO. SD-172648-0001		SHEET NO. 1 OF 1		TITLE 3 CKT GLOW WIRE HEADER MINI-FIT JR. SERIES (SINGLE ROW) molex	
THIS DRAWING CONTAINS INFORMATION THAT IS PROPRIETARY TO MOLEX INCORPORATED AND SHOULD NOT BE USED WITHOUT WRITTEN PERMISSION									