

LOC	DIST	REV	DATE	APPD
A1	-	-	-	-

REV	DATE	APPD	DESCRIPTION
A1	13JAN2011	CG	add version 5-1418647-5
A2	02SEP2011	CR	deleted vers. 5-1418647-5
B	09MAY2023	CG	Ferrit geändert

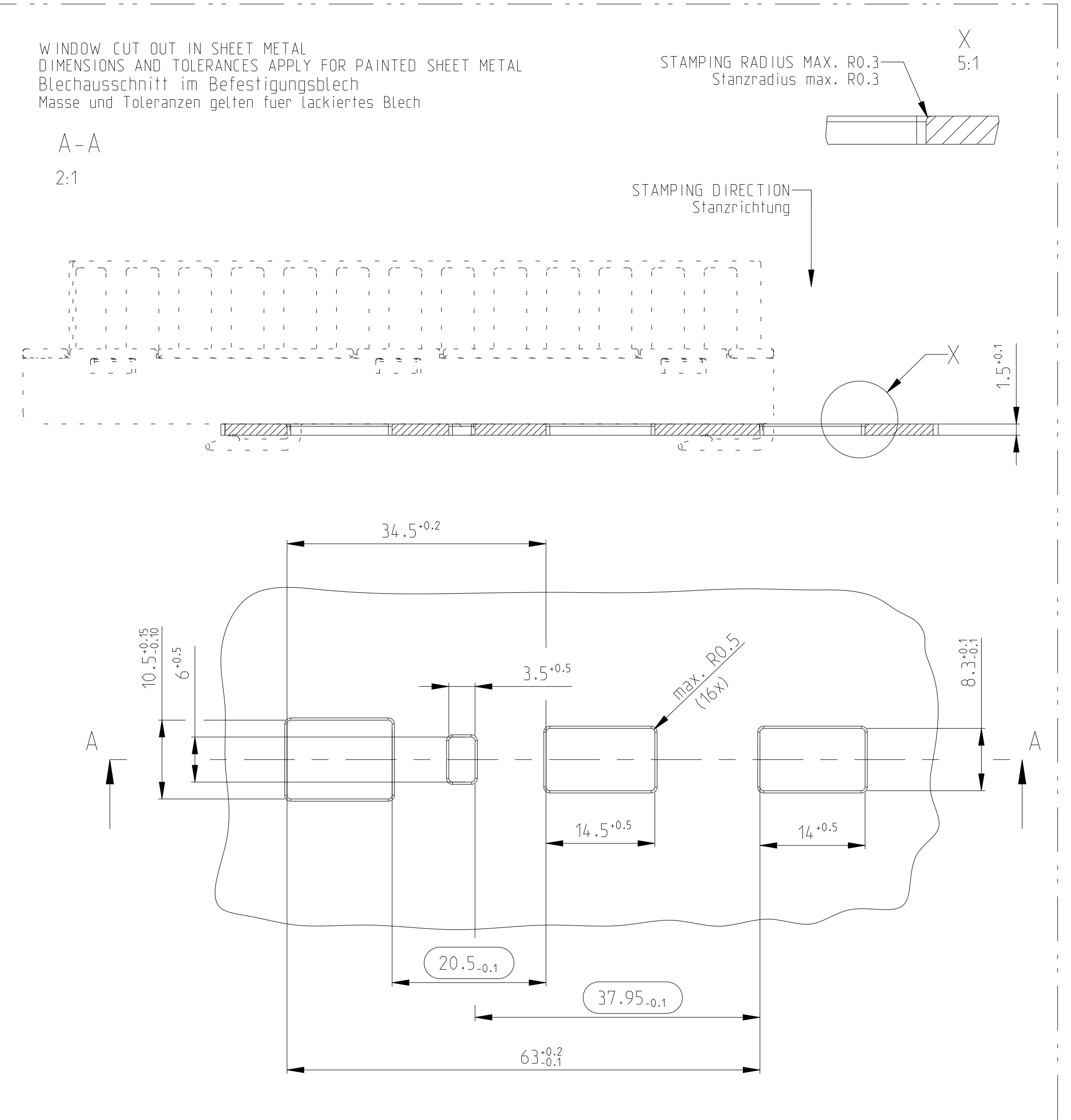
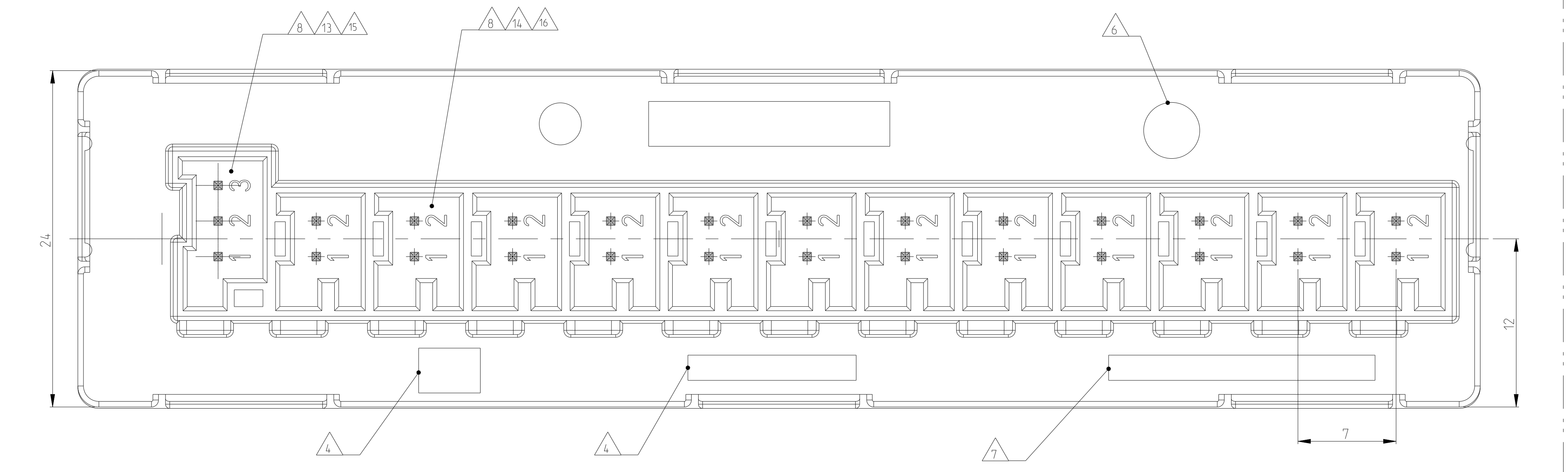
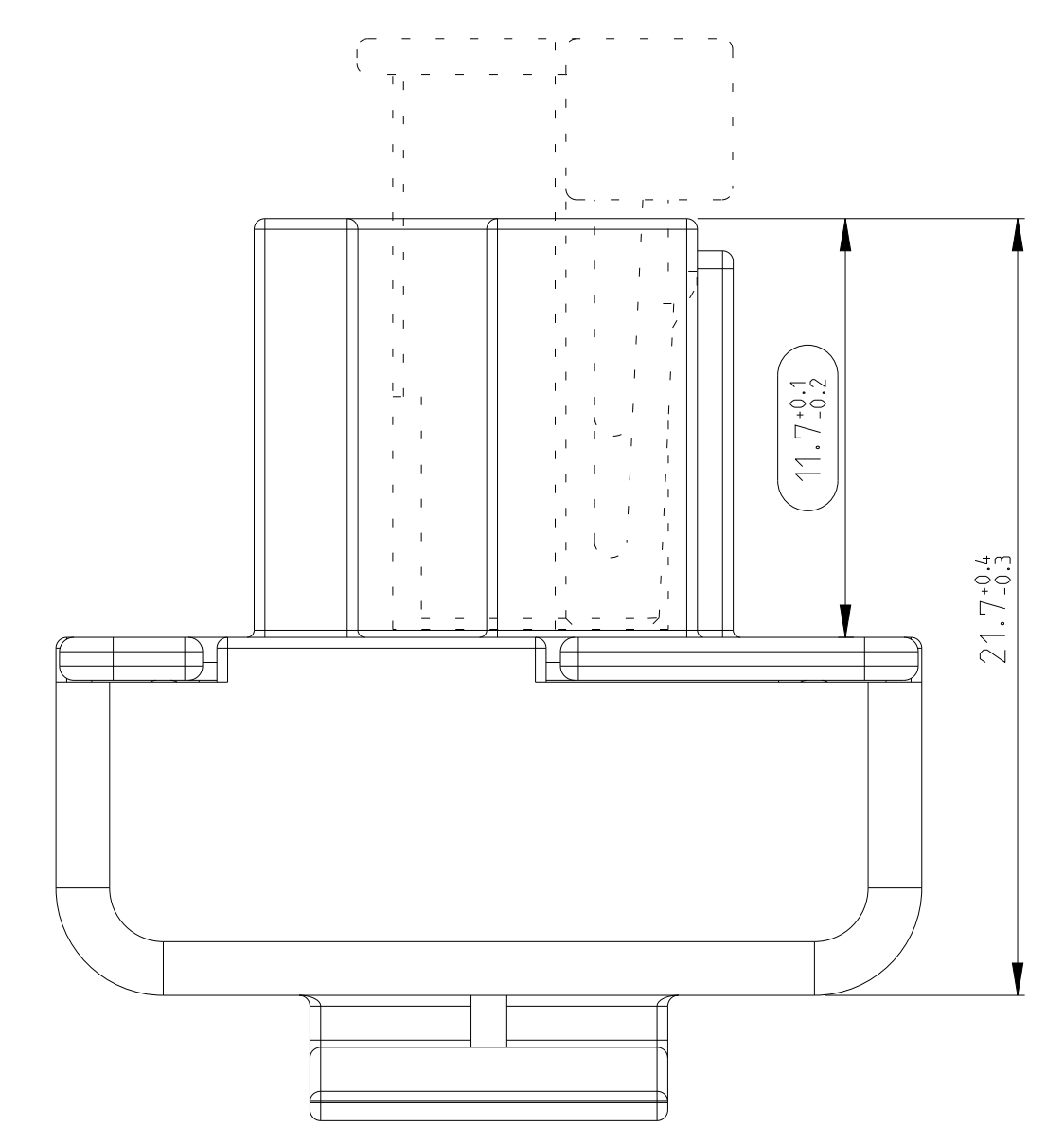
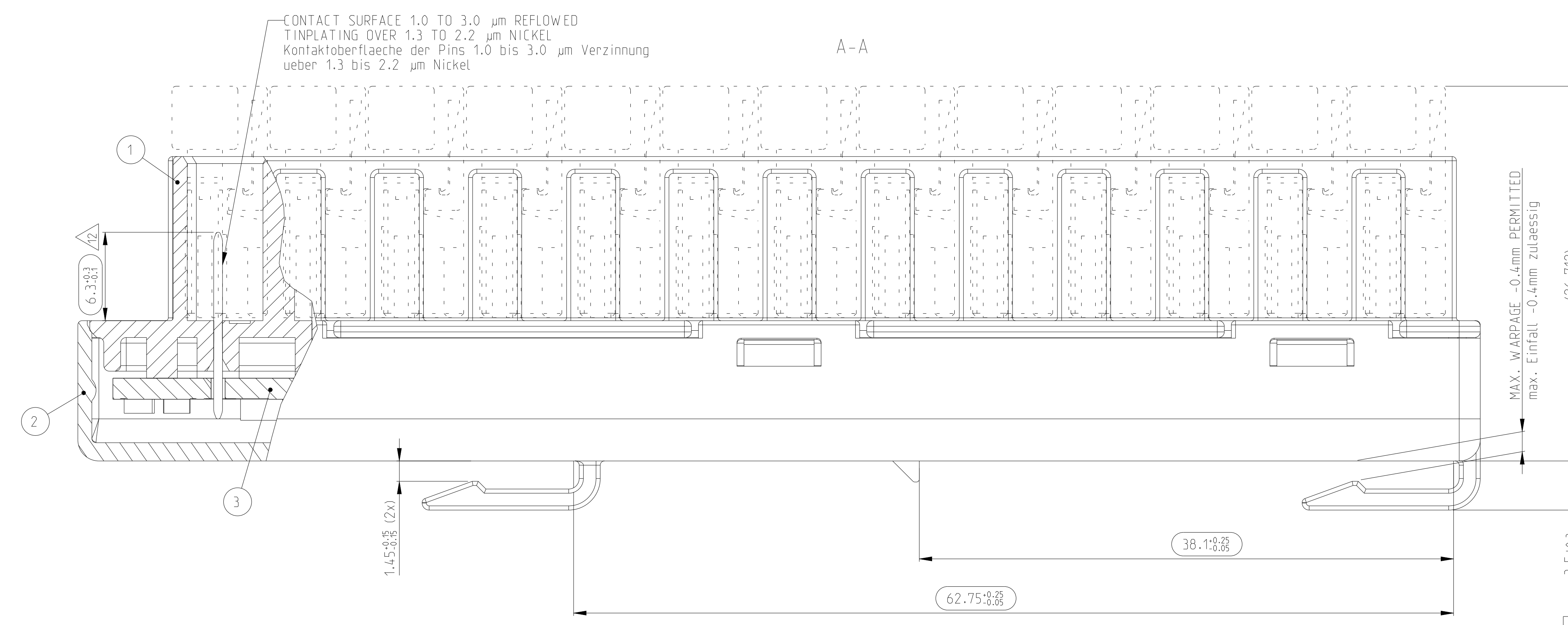
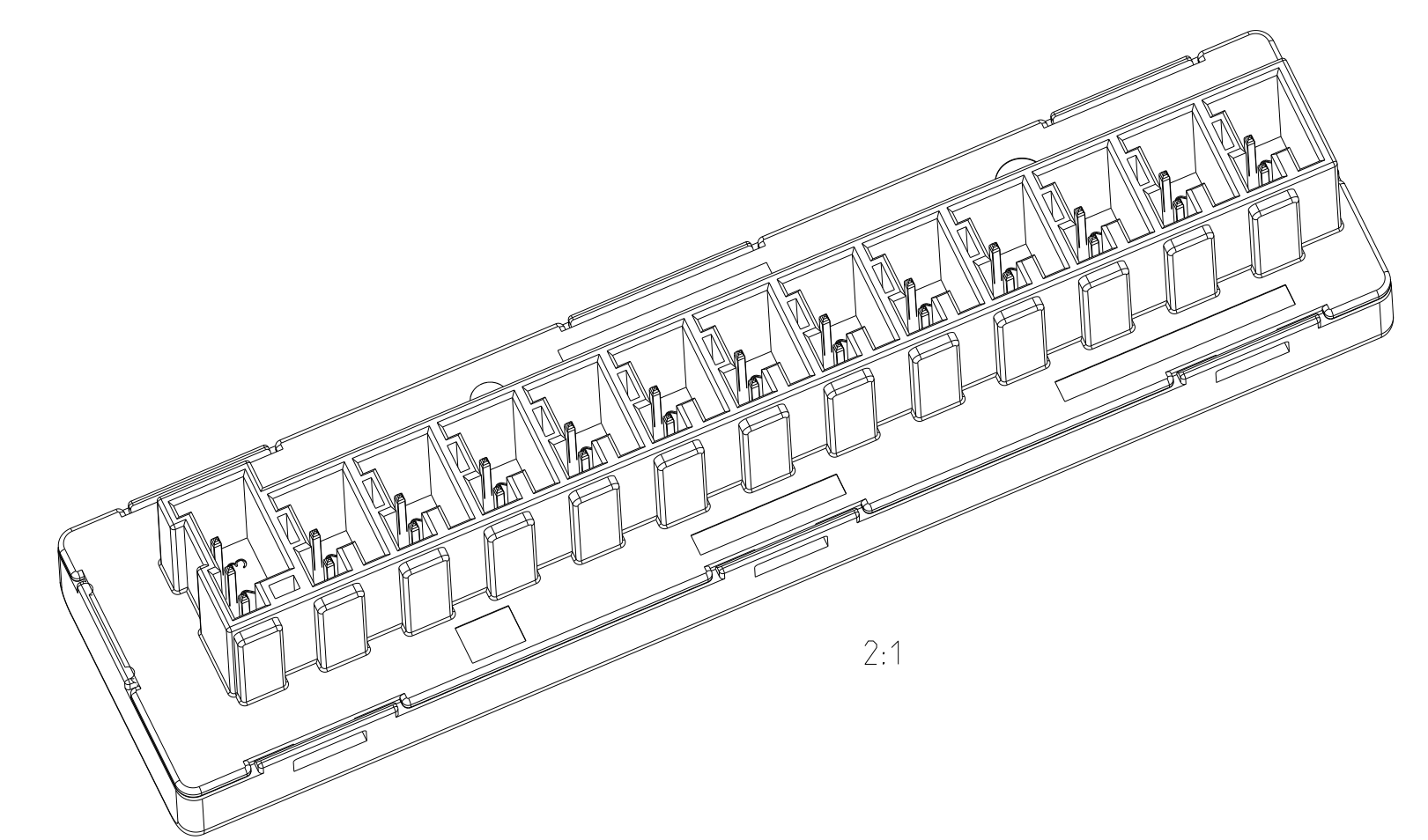
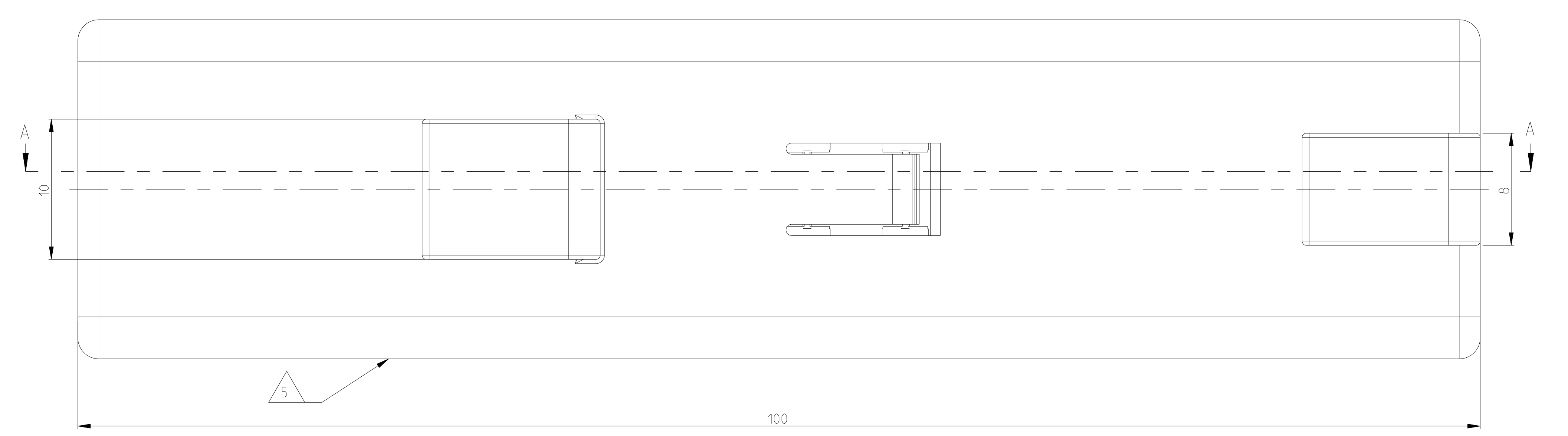

NOTES:

- Bemerkungen:
- ONLY THE GERMAN LANGUAGE SHALL BE BINDING
Massgebend ist der deutsche Text
 - 1- -1 AS SHOWN
wie gezeichnet
 - FUNCTIONAL MEASUREMENTS MARKED WITH ARE DOCUMENTED IN THE PPFB. NOT MARKED MEASUREMENTS ARE MEASURED, BUT NOT DOCUMENTED IN THE PPFB. DEVIATIONS HAVE TO BE CORRECTED.
Funktionsbestimmende Masse, die mit gekennzeichnet sind, werden im PPFB dokumentiert. Nicht gekennzeichnete Masse werden ebenfalls gemessen, aber nicht im PPFB dokumentiert. Abweichungen sind zu korrigieren.
 - SUPPLIER MARK
Lieferantenkennzeichnung
 - MANUFACTURING IDENTIFIER
Herstellungskennung
 - DATE INSERT
Datumstempel
 - MATERIAL IDENTIFICATION
Materialkennzeichnung
 - CODINGS ACCORDING TO THE CODING DESIGNATION OF THE SPECIFICATION AND THE SUITABLE SOCKET HOUSINGS.
Kodierungen entsprechen den Kodierungsbezeichnungen der AV und der zugehörigen Buchsengehäuse.
 - SMD-PARTS ON PRINTED CIRCUIT BOARD:
RESISTORS:
R1 AND R2 = 56-64 Ω ±1%, 750 mW; R3 = 10 Ω ±5% 200 mW
CONDENSER: C1 = 47 nF
FERRIT (CHIPS): K = TDK MHF2012FRC570ATD25
SMD-Bauteile auf der Leiterplatte:
Widerstände:
R1 und R2 = 56-64 Ω ±1%, 750 mW; R3 = 10 Ω ±5% 200 mW
Kondensator: C1 = 47 nF
Ferritkerne: K = TDK MHF2012FRC570ATD25
 - SMD-PARTS ON PRINTED CIRCUIT BOARD:
RESISTORS:
R1 AND R2 = 28-32 Ω ±1%, 250 mW; R3 = 10 Ω ±5% 200 mW
CONDENSER: C1 = 47 nF
SMD-Bauteile auf der Leiterplatte:
Widerstände:
R1 und R2 = 28-32 Ω ±1%, 250 mW; R3 = 10 Ω ±5% 200 mW
Kondensator: C1 = 47 nF
 - DIMENSION WAS DETERMINED DIFFERENT FROM SPECIFICATION
114-18562 AND 114-18563
Masse abweichend von Ausführungsvorschrift 114-18562 und 114-18563 fertig!

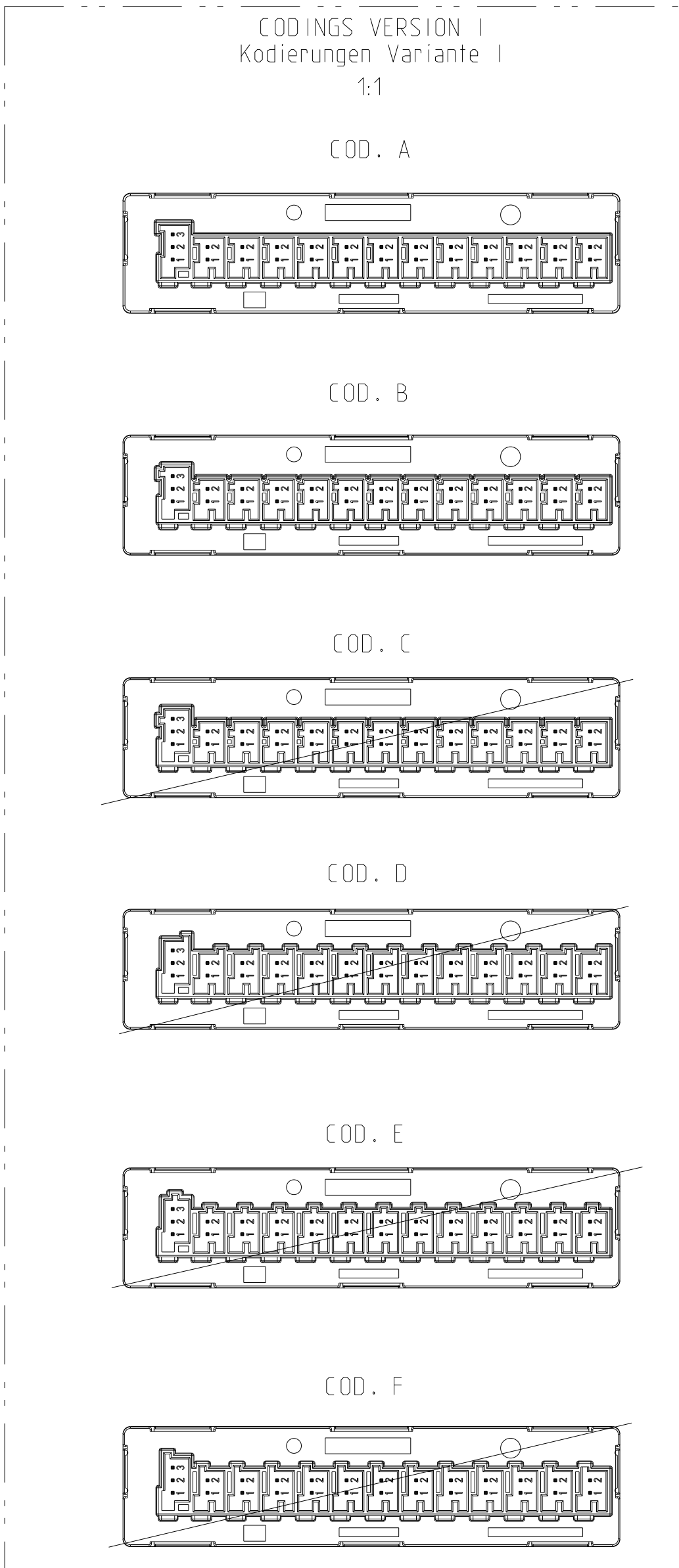

NOTE Bem.	FEATURE Merkmal	TE Connectivity - No.
	AV - INTERFACE AV - Schnittstelle	114-18563
	AV - INTERFACE AV - Schnittstelle	114-18562
	USEABLE SOCKET HSG passende Kupplung	1418640
	USEABLE SOCKET HSG passende Kupplung	1418639
	PRODUCT SPEC. Product Spec.	108-18861

TITLE Benennung	Mass (kg) MASS (kg)	COD	TE Connectivity ORDER-NO.	REV	QTY	Benennung	MATERIAL	Farbe/Oberfläche COLOUR/SURFACE	ITEM
Energieverteiler CAN 12x2pol./1x3pol.	0.021	B	2-1418647-5	D	1	Leiterplatte bestückt PRINTED CIRCUIT BOARD	PA6-GFK 10/20 ultramid 830a2/8401	grün/GREEN	1
				D	1	Deckel COVER	PA6-GFK 10/20 ultramid 830a2/8401	natur/NATURE	2
				D	1	SIHfwanne 12x2/1x3pol. MGS PIN HEADER 12X2/1X3POS. MGS	PA6-GFK 10/20 ultramid 830a2/8401	braun/BROWN	1
Energieverteiler CAN 12x2pol./1x3pol.	0.021	A	1-1418647-5	C	1	Leiterplatte bestückt PRINTED CIRCUIT BOARD	PA6-GFK 10/20 ultramid 830a2/8401	grün/GREEN	1
				C	1	Deckel COVER	PA6-GFK 10/20 ultramid 830a2/8401	natur/NATURE	2
				C	1	SIHfwanne 12x2/1x3pol. MGS PIN HEADER 12X2/1X3POS. MGS	PA6-GFK 10/20 ultramid 830a2/8401	braun/BROWN	1

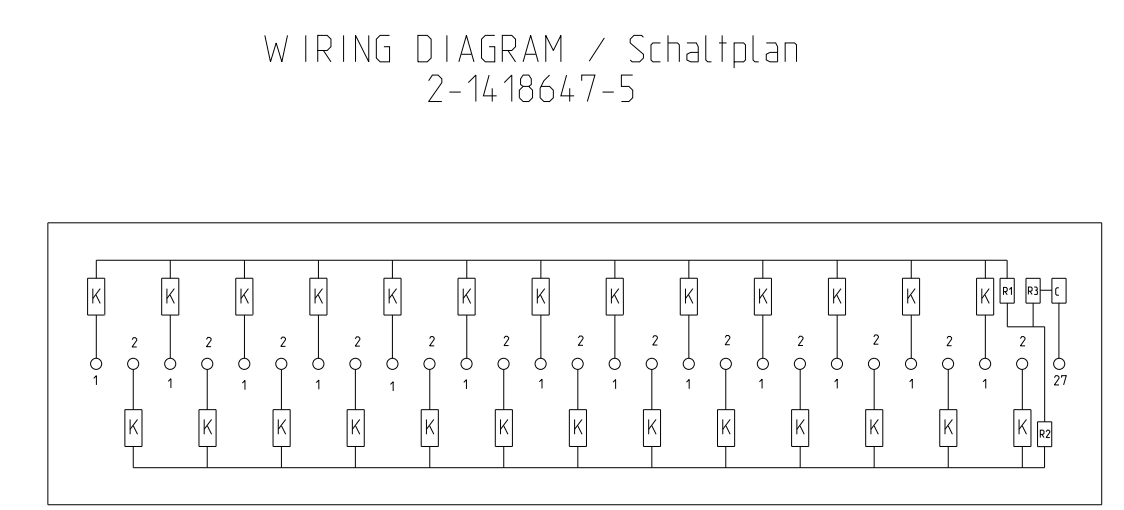
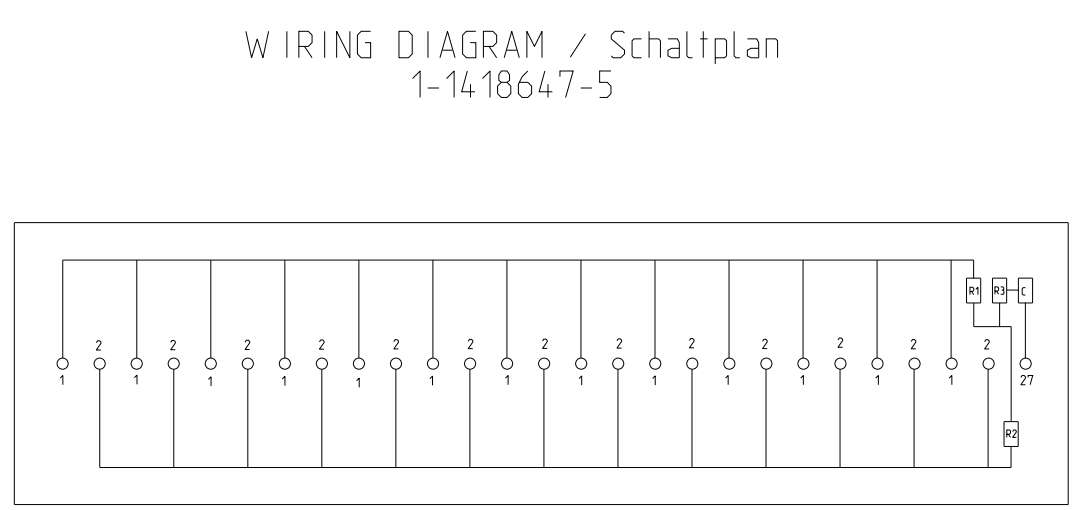
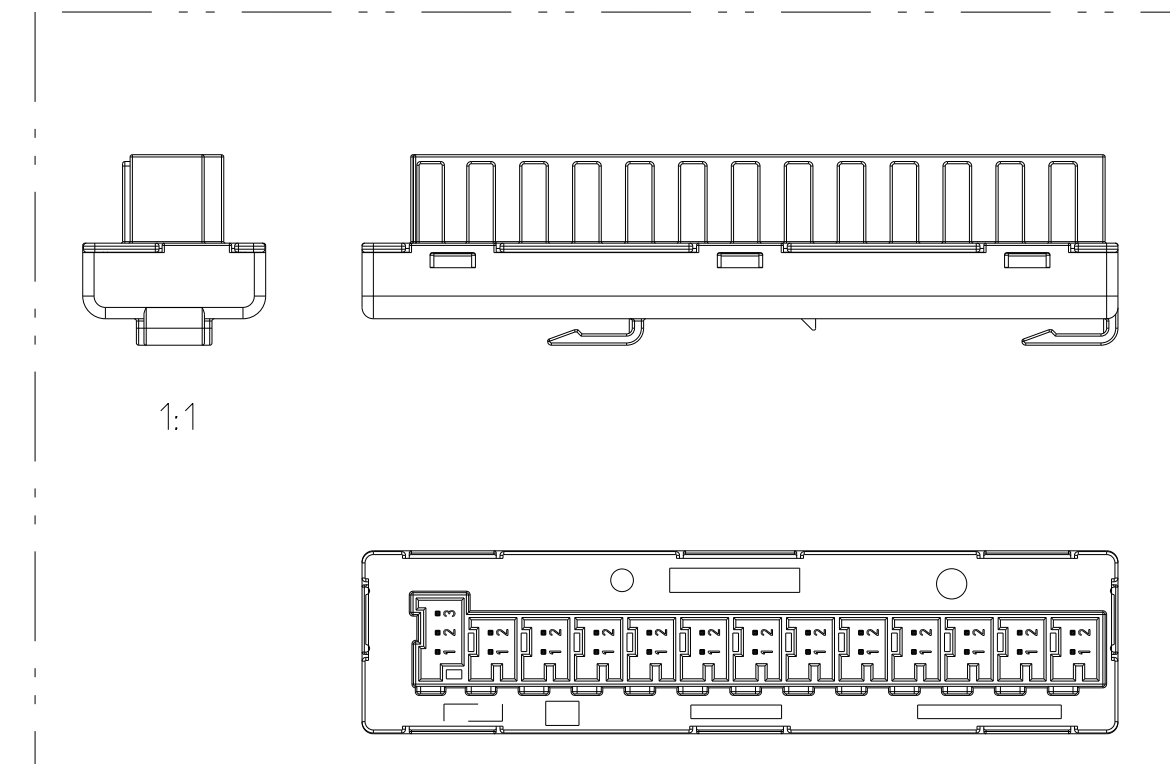

THIS DRAWING IS A CONTROLLED DOCUMENT.

DATE: 12JAN2010	APPD: C Reck
DATE: 22FEB2010	APPD: C Geiger
DATE: 22FEB2010	APPD: H Holland
DATE: 02SEP2011	APPD: H Geiger

STE TE Connectivity

POTENTIAL DISTRIBUTION 27POS.
Potentialverteiler 27pol.
Micro Quadlock System

Customer Drawing

SCALE: 1:1

SHEET: 1 OF 1

REV: B