

REV.	DATE	ECR NO.	DESCRIPTION
NC	01/02/08	XXXXXX	INITIAL RELEASE
A	04/21/12	XXXXXX	ADD RECOMMENDED MOUNTING HOLE

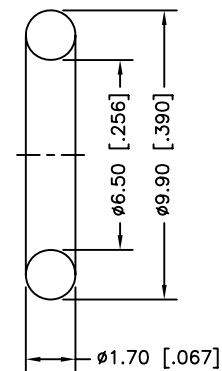
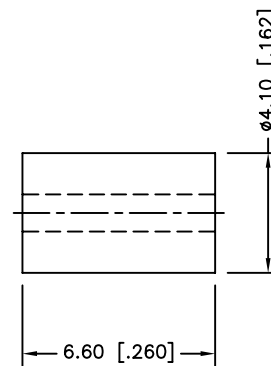
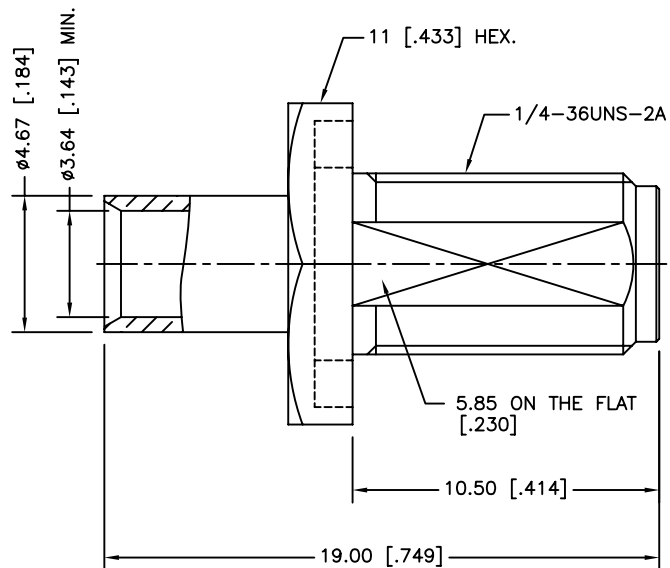
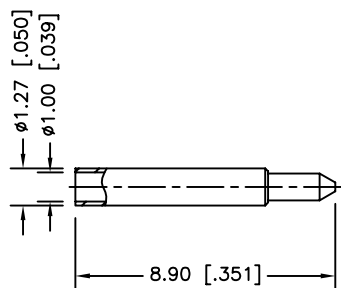
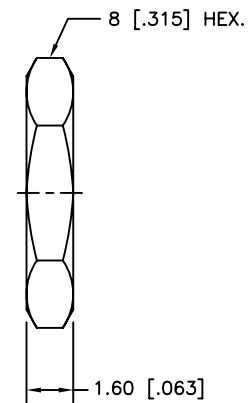
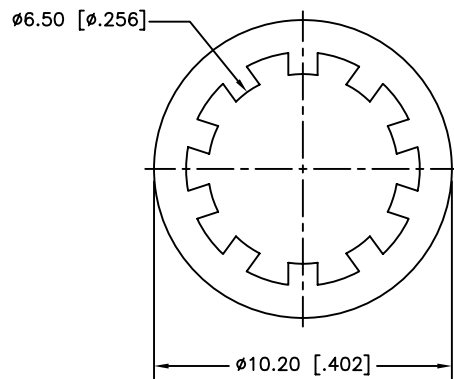

- CONTACT PIN TO SOLDER
- MAX. PANEL THICKNESS=2.4mm

UNLESS OTHERWISE SPECIFIED DIMENSIONS ARE IN MILLIMETERS. DIMENSIONS IN [] ARE IN INCHES AND FOR CUSTOMER REFERENCE ONLY.

UNLESS OTHERWISE SPECIFIED TOLERANCES FOR MILLIMETERS ARE:
 0.5 - 8mm ± 0.20mm
 8 - 30mm ± 0.40mm
 30 - 120mm ± 0.50mm

UNLESS OTHERWISE SPECIFIED TOLERANCES FOR INCHES ARE:
 .020 - .315 ± 0.007"
 .315 - 1.180 ± 0.015"
 1.180 - 4.724 ± 0.020"

DO NOT SCALE DRAWING

APPROVALS		DATE
DRAWN	M.ZHANG	04/21/12
CHECKED		
ISSUED		
SHEET	1 OF 1	
CAD FILE	C:/CONNEX/132106RP.DWG	

Amphenol Connex

PART DESCRIPTION			
SMA REVERSE POLARITY DIRECT SOLDER BULKHEAD JACK (FOR .141" SEMI-RIGID CABLE)			
PART NO.		132106RP	
DWG. NO.	132106RP.DWG	REV.	A
SIZE	A	SCALE	NA

DESCRIPTION	MATERIAL	FINISH	QTY	
6	HEX NUT	BRASS	GOLD	1
5	LOCK WASHER	BRASS	GOLD	1
4	GASKET	SILICON RUBBER	RED	1
3	CONTACT PIN	BRASS	GOLD	1
2	INSULATOR	PTFE	NATURAL	1
1	BODY	BRASS	GOLD	1