

# bq2423xx USB-Friendly Lithium-Ion Battery Charger and Power-Path Management IC

## 1 Features

- Fully Compliant USB Charger
  - Selectable 100-mA and 500-mA Maximum Input Current
  - 100-mA Maximum Current Limit Ensures Compliance to USB-IF Standard
  - Input-based Dynamic Power Management ( $V_{IN}$ -DPM) for Protection Against Poor USB Sources
- 28-V Input Rating With Overvoltage Protection
- 4.35-V Battery Regulation
- Integrated Dynamic Power-Path Management (DPPM) Function Simultaneously and Independently Powers the System and Charges the Battery
- Supports up to 500-mA Charge Current With Current Monitoring Output (ISET)
- Programmable Input Current Limit up to 500 mA for Wall Adapters
- Programmable Termination Current (bq24232H)
- Programmable Precharge and Fast-Charge Safety Timers
- Reverse Current, Short-Circuit, and Thermal Protection
- NTC Thermistor Input
- Proprietary Start-up Sequence Limits Inrush Current
- Status Indication – Charging/Done, Power Good
- Small 3-mm × 3-mm 16-Lead QFN Package

## 2 Applications

- Bluetooth® Devices
- Low-Power Handheld Devices

## 3 Description

The bq2423xH series of devices are highly integrated Li-ion linear chargers and system power-path management devices targeted at space-limited portable applications. The devices operate from either a USB port or AC adapter and support charge currents from 25 mA to 500 mA. The high-input voltage range with input overvoltage protection supports low-cost, unregulated adapters. The USB input current limit accuracy and start-up sequence allow the bq2423xH to meet USB-IF inrush current specifications. Additionally, the input dynamic power management ( $V_{IN}$ -DPM) prevents the charger from crashing poorly designed or incorrectly configured USB sources.

The bq2423xH features dynamic power-path management (DPPM) that powers the system while simultaneously and independently charging the battery. The DPPM circuit reduces the charge current when the input current limit causes the system output to fall to the DPPM threshold, thus supplying the system load at all times while monitoring the charge current separately. This feature reduces the number of charge and discharge cycles on the battery, allows for proper charge termination, and enables the system to run with a defective or absent battery pack. Additionally, this feature enables instant system turn-on even with a totally discharged battery. The power-path management architecture also lets the battery supplement the system current requirements when the adapter cannot deliver the peak system currents, thus enabling the use of a smaller adapter.

The battery is charged in three phases: conditioning, constant current, and constant voltage. In all charge phases, an internal control loop monitors the IC junction temperature and reduces the charge current if the internal temperature threshold is exceeded.

The charger power stage and charge current sense functions are fully integrated. The charger function has high-accuracy current and voltage regulation loops, charge status display, and charge termination. The input current limit and charge current are programmable using external resistors.

### Device Information<sup>(1)</sup>

PART NUMBER	PACKAGE	BODY SIZE (NOM)
bq2423xx	VQFN (16)	3.00 mm x 3.00 mm

(1) For all available packages, see the orderable addendum at the end of the datasheet.

### Typical Application Circuit

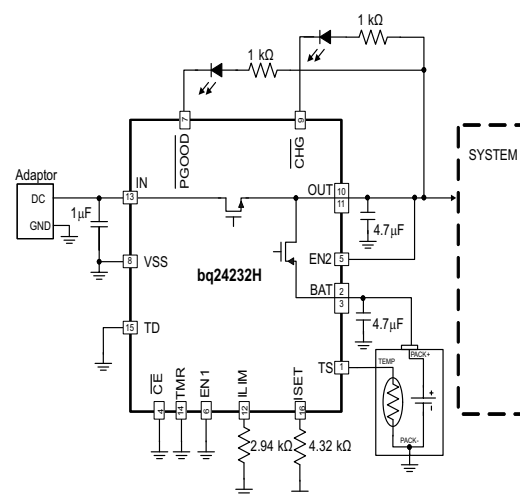

## Table of Contents

<b>1 Features</b> .....	<b>1</b>	9.1 Application Information.....	<b>25</b>
<b>2 Applications</b> .....	<b>1</b>	9.2 Typical Application .....	<b>25</b>
<b>3 Description</b> .....	<b>1</b>	9.3 System Examples .....	<b>30</b>
<b>4 Revision History</b> .....	<b>2</b>	<b>10 Power Supply Recommendations</b> .....	<b>31</b>
<b>5 Device Comparison Table</b> .....	<b>3</b>	10.1 Requirements for OUT Output.....	<b>31</b>
<b>6 Pin Configuration and Functions</b> .....	<b>3</b>	10.2 USB Sources and Standard AC Adapters .....	<b>31</b>
<b>7 Specifications</b> .....	<b>4</b>	10.3 Half-Wave Adapters .....	<b>31</b>
7.1 Absolute Maximum Ratings .....	<b>4</b>	<b>11 Layout</b> .....	<b>31</b>
7.2 ESD Ratings.....	<b>4</b>	11.1 Layout Guidelines .....	<b>31</b>
7.3 Recommended Operating Conditions .....	<b>5</b>	11.2 Layout Example .....	<b>32</b>
7.4 Thermal Information .....	<b>5</b>	11.3 Thermal Package .....	<b>33</b>
7.5 Electrical Characteristics.....	<b>5</b>	<b>12 Device and Documentation Support</b> .....	<b>34</b>
7.6 Typical Characteristics .....	<b>9</b>	12.1 Documentation Support .....	<b>34</b>
<b>8 Detailed Description</b> .....	<b>11</b>	12.2 Related Links .....	<b>34</b>
8.1 Overview .....	<b>11</b>	12.3 Trademarks .....	<b>34</b>
8.2 Functional Block Diagram .....	<b>12</b>	12.4 Electrostatic Discharge Caution.....	<b>34</b>
8.3 Feature Description.....	<b>13</b>	12.5 Glossary .....	<b>34</b>
8.4 Device Functional Modes.....	<b>23</b>	<b>13 Mechanical, Packaging, and Orderable Information</b> .....	<b>34</b>
<b>9 Application and Implementation</b> .....	<b>25</b>		

## 4 Revision History

<b>Changes from Revision A (November 2014) to Revision B</b>	<b>Page</b>
• Changed from "Table 2" to "Table 1" in the Pin Functions Description column for EN1/EN2 .....	<b>3</b>

<b>Changes from Original (January 2014) to Revision A</b>	<b>Page</b>
• Added <i>ESD Ratings</i> table, <i>Feature Description</i> section, <i>Device Functional Modes</i> , <i>Application and Implementation</i> section, <i>Power Supply Recommendations</i> section, <i>Layout</i> section, <i>Device and Documentation Support</i> section, and <i>Mechanical, Packaging, and Orderable Information</i> section .....	<b>1</b>

## 5 Device Comparison Table

PART NUMBER <sup>(1) (2)</sup>	V <sub>OVP</sub>	V <sub>OUT(REG)</sub>	V <sub>DPM</sub>	OPTIONAL FUNCTION	MARKING
bq24230HRGTR <sup>(3)</sup>	6.6 V	4.5 V	V <sub>O(REG)</sub> – 100 mV	TD	24230H
bq24230HRGTT <sup>(3)</sup>	6.6 V	4.5 V	V <sub>O(REG)</sub> – 100 mV	TD	24230H
bq24232HRGTR	10.5 V	4.5 V	V <sub>O(REG)</sub> – 100 mV	ITERM	24232H
bq24232HRGTT	10.5 V	4.5 V	V <sub>O(REG)</sub> – 100 mV	ITERM	24232H

- The RGT package is available in the following options:  
R - taped and reeled in quantities of 3000 devices per reel.  
T - taped and reeled in quantities of 250 devices per reel.
- This product is RoHS compatible, including a lead concentration that does not exceed 0.1% of total product weight, and is suitable for use in specified lead-free soldering processes. In addition, this product uses package materials that do not contain halogens, including bromine (Br) or antimony (Sb) above 0.1% of total product weight.
- Product Preview

## 6 Pin Configuration and Functions

**RGT Package  
16 Pins  
Top View**

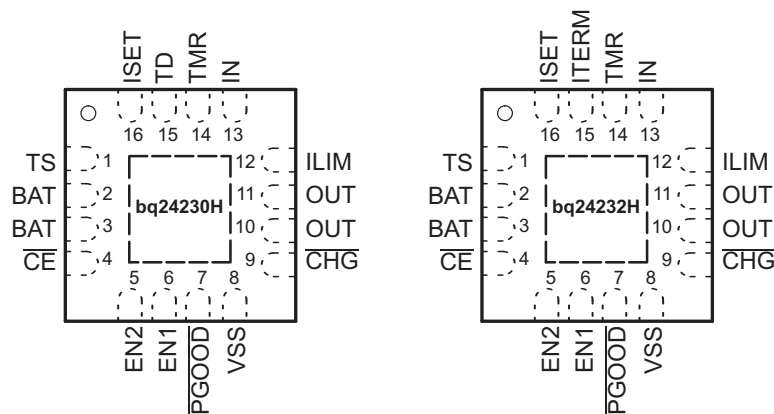

**Pin Functions**

NAME	PIN NUMBER		I/O	DESCRIPTION
	'230H	'232H		
BAT	2, 3	2, 3	I/O	Charger Power Stage Output and Battery Voltage Sense Input. Connect BAT to the positive terminal of the battery. Bypass BAT to VSS with a 4.7- $\mu$ F to 47- $\mu$ F ceramic capacitor.
$\overline{\text{CE}}$	4	4	I	Charge Enable Active-Low Input. Connect $\overline{\text{CE}}$ to a high logic level to place the battery charger in standby mode. In standby mode, OUT is active and battery supplement mode is still available. Connect $\overline{\text{CE}}$ to a low logic level to enable the battery charger. $\overline{\text{CE}}$ is internally pulled down with approximately 285 k $\Omega$ . Do not leave $\overline{\text{CE}}$ unconnected to ensure proper operation.
$\overline{\text{CHG}}$	9	9	O	Open-Drain Charging Status Indication Output. $\overline{\text{CHG}}$ pulls to VSS when the battery is charging. $\overline{\text{CHG}}$ is high impedance when charging is complete and when charger is disabled.
EN1	6	6	I	Input Current Limit Configuration Inputs. Use EN1 and EN2 control the maximum input current and enable USB compliance. See Table 1 for the description of the operation states. EN1 and EN2 are internally pulled down with approximately 285 k $\Omega$ . Do not leave EN1 or EN2 unconnected to ensure proper operation.
EN2	5	5	I	
ILIM	12	12	I	Adjustable Current Limit Programming Input. Connect a 3.1-k $\Omega$ to 7.8-k $\Omega$ resistor from ILIM to VSS to program the maximum input current (EN2=1, EN1=0). The input current includes the system load and the battery charge current.
IN	13	13	I	Input Power Connection. Connect IN to the connected to external DC supply (AC adapter or USB port). The input operating range is 4.35 V to 6.6 V. The input can accept voltages up to 26 V without damage but operation is suspended. Connect bypass capacitor 1 $\mu$ F to 10 $\mu$ F to VSS.
ISET	16	16	I/O	Fast-Charge Current Programming Input. Connect a 3-k $\Omega$ to 36-k $\Omega$ resistor from ISET to VSS to program the fast-charge current level. Charging is disabled if ISET is left unconnected. While charging, the voltage at ISET reflects the actual charging current and can be used to monitor charge current. See the <a href="#">Charge Current Translator</a> section for more details.

### Pin Functions (continued)

NAME	PIN NUMBER		I/O	DESCRIPTION
	'230H	'232H		
ITERM	-	15	I	Termination Current Programming Input. Connect a 0-Ω to 15-kΩ resistor from ITERM to VSS to program the termination current. Leave ITERM unconnected to set the termination current to the internal default 10% threshold.
OUT	10,11	10, 11	O	System Supply Output. OUT provides a regulated output when the input is below the OVP threshold and above the regulation voltage. When the input is out of the operation range, OUT is connected to V <sub>BAT</sub> . Connect OUT to the system load. Bypass OUT to VSS with a 4.7-μF to 47-μF ceramic capacitor.
$\overline{\text{PGOOD}}$	7	7	O	Open-drain Power Good Status Indication Output. $\overline{\text{PGOOD}}$ pulls to VSS when a valid input source is detected. $\overline{\text{PGOOD}}$ is high-impedance when the input power is not within specified limits. Connect $\overline{\text{PGOOD}}$ to the desired logic voltage rail using a 1-kΩ to 100-kΩ resistor, or use with an LED for visual indication.
TD	15	-	I	Termination Disable Input. Connect TD high to disable charger termination. Connect TD to VSS to enable charger termination. TD is checked during start-up only and cannot be changed during operation. See the TD section in this data sheet for a description of the behavior when termination is disabled. TD is internally pulled down to VSS with approximately 285 kΩ. Do not leave TD unconnected to ensure proper operation.
Thermal Pad			-	An internal electrical connection exists between the exposed thermal pad and the VSS pin of the device. The thermal pad must be connected to the same potential as the VSS pin on the printed-circuit board. Do not use the thermal pad as the primary ground input for the device. The VSS pin must be connected to ground at all times.
TMR	14	14	I	Timer Programming Input. TMR controls the precharge and fast-charge safety timers. Connect TMR to VSS to disable all safety timers. Connect a 18-kΩ to 72-kΩ resistor between TMR and VSS to program the timers a desired length. Leave TMR unconnected to set the timers to the 5-hour fast charge and 30-minute precharge default timer values.
TS	1	1	I	External NTC Thermistor Input. Connect the TS input to the NTC thermistor in the battery pack. TS monitors a 10-kΩ NTC thermistor. For applications that do not use the TS function, connect a 10-kΩ fixed resistor from TS to VSS to maintain a valid voltage level on TS.
VSS	8	8	-	Ground. Connect to the thermal pad and to the ground rail of the circuit.

## 7 Specifications

### 7.1 Absolute Maximum Ratings<sup>(1)</sup>

over the 0°C to 125°C operating free-air temperature range (unless otherwise noted)

		MIN	MAX	UNIT	
V <sub>I</sub>	Input voltage	IN (with respect to VSS)	-0.3	28	V
		OUT (with respect to VSS)	-0.3	7	V
		BAT (with respect to VSS)	-0.3	5	V
		EN1, EN2, $\overline{\text{CE}}$ , TS, ISET, $\overline{\text{PGOOD}}$ , $\overline{\text{CHG}}$ , ILIM, TMR, TD, ITERM (with respect to VSS)	-0.3	7	V
I <sub>I</sub>	Input current	IN	600	mA	
I <sub>O</sub>	Output current (continuous)	OUT	1700	mA	
		BAT (Discharge mode)	1700	mA	
	Output sink current	$\overline{\text{CHG}}$ , $\overline{\text{PGOOD}}$	15	mA	
T <sub>J</sub>	Junction temperature	-40	150	°C	
T <sub>stg</sub>	Storage temperature	-65	150	°C	

- (1) Stresses beyond those listed under absolute maximum ratings may cause permanent damage to the device. These are stress ratings only, and functional operation of the device at these or any other conditions beyond those indicated under [Recommended Operating Conditions](#) is not implied. Exposure to absolute-maximum-rated conditions for extended periods may affect device reliability. All voltage values are with respect to the network ground terminal unless otherwise noted.

### 7.2 ESD Ratings

		VALUE	UNIT
V <sub>(ESD)</sub>	Electrostatic discharge	Human body model (HBM), per ANSI/ESDA/JEDEC JS-001 <sup>(1)</sup>	±2000
		Charged-device model (CDM), per JEDEC specification JESD22-C101 <sup>(2)</sup>	±500

- (1) JEDEC document JEP155 states that 500-V HBM allows safe manufacturing with a standard ESD control process. Manufacturing with less than 500-V HBM is possible with the necessary precautions. Pins listed as ±2000 V may actually have higher performance.
- (2) JEDEC document JEP157 states that 250-V CDM allows safe manufacturing with a standard ESD control process. Manufacturing with less than 250-V CDM is possible with the necessary precautions. Pins listed as ±500 V may actually have higher performance.

### 7.3 Recommended Operating Conditions

			MIN	MAX	UNIT
V <sub>I</sub>	IN voltage range		4.35	26	V
	IN operating voltage range	'230H	4.35	6.4	V
		'232H	4.35	10.2	
I <sub>IN</sub>	Input current, IN pin			500	mA
I <sub>OUT</sub>	Current, OUT pin			1500	mA
I <sub>BAT</sub>	Current, BAT pin (discharging)			1500	mA
I <sub>CHG</sub>	Current, BAT pin (charging)			500	mA
T <sub>J</sub>	Junction temperature		−40	125	°C
R <sub>ILIM</sub>	Maximum input current programming resistor		3.1	7.8	kΩ
R <sub>ISET</sub>	Fast-charge current programming resistor		1.74	34.8	kΩ
R <sub>TMR</sub>	Timer programming resistor		18	72	kΩ
R <sub>ITERM</sub>	Termination programming resistor	'232H	0	15	kΩ

### 7.4 Thermal Information

THERMAL METRIC <sup>(1)</sup>		bq2423xx	UNIT
		RGT	
		16 PINS	
θ <sub>JA</sub>	Junction-to-ambient thermal resistance	44.5	°C/W
θ <sub>JCtop</sub>	Junction-to-case (top) thermal resistance	54.2	
θ <sub>JB</sub>	Junction-to-board thermal resistance	17.2	
ψ <sub>JT</sub>	Junction-to-top characterization parameter	1.0	
ψ <sub>JB</sub>	Junction-to-board characterization parameter	17.1	
θ <sub>JCbot</sub>	Junction-to-case (bottom) thermal resistance	3.8	

(1) For more information about traditional and new thermal metrics, see the IC Package Thermal Metrics application report, [SPRA953](#).

### 7.5 Electrical Characteristics

over operating free-air temperature range (unless otherwise noted)

PARAMETER	TEST CONDITIONS	MIN	TYP	MAX	UNIT	
<b>INPUT</b>						
UVLO	Undervoltage lockout	V <sub>IN</sub> : 0 V → 4 V	3.2	3.3	3.4	V
V <sub>hys(UVLO)</sub>	Hysteresis on UVLO	V <sub>IN</sub> : 4 V → 0 V	200		300	mV
V <sub>IN(DT)</sub>	Input power detection threshold	Input power detected when V <sub>IN</sub> > V <sub>BAT</sub> + V <sub>IN(DT)</sub> V <sub>BAT</sub> = 3.6 V, V <sub>IN</sub> : 3.5 V → 4 V	55	95	145	mV
V <sub>hys(INDT)</sub>	Hysteresis on V <sub>IN(DT)</sub>	V <sub>BAT</sub> = 3.6 V, V <sub>IN</sub> : 4 V → 3.5 V	20			mV
t <sub>DGL(PGOOD)</sub>	Deglintch time, input power detected status	Time measured from V <sub>IN</sub> : 0 V → 5 V 1-μs rise time to PGOOD = LO		2		ms
V <sub>OVP</sub>	Input overvoltage protection threshold	('230H) V <sub>IN</sub> : 5 V → 7 V	6.4	6.6	6.8	V
		('232H) V <sub>IN</sub> : 5 V → 11 V	10.2	10.5	10.8	
V <sub>hys(OVP)</sub>	Hysteresis on OVP	('230H) V <sub>IN</sub> : 7 V → 5V ( '232H) V <sub>IN</sub> : 11 V → 5 V		110		mV
t <sub>DGL(OVP)</sub>	Input overvoltage blanking time			50		
t <sub>REC(OVP)</sub>	Input overvoltage recovery time	Time measured from V <sub>IN</sub> : 11 V → 5 V 1 μs fall time to PGOOD = LO		2		ms
<b>ILIM, ISET SHORT-CIRCUIT TEST</b>						
I <sub>SC</sub>	Current source	V <sub>IN</sub> > UVLO and V <sub>IN</sub> > V <sub>BAT</sub> + V <sub>IN(DT)</sub>		1.3		mA
V <sub>SC</sub>		V <sub>IN</sub> > UVLO and V <sub>IN</sub> > V <sub>BAT</sub> + V <sub>IN(DT)</sub>		520		mV
<b>QUIESCENT CURRENT</b>						
I <sub>BAT(PDWN)</sub>	Sleep current into BAT pin	CE = LO or HI, input power not detected, no load on OUT pin, T <sub>J</sub> = 85°C			6.5	μA

## Electrical Characteristics (continued)

over operating free-air temperature range (unless otherwise noted)

PARAMETER		TEST CONDITIONS	MIN	TYP	MAX	UNIT
$I_{IN(STDBY)}$	Standby current into IN pin	EN1 = HI, EN2 = HI, $V_{IN} = 6\text{ V}$ , $T_J = 85^\circ\text{C}$			50	$\mu\text{A}$
		EN1 = HI, EN2 = HI, $V_{IN} = 10\text{ V}$ , $T_J = 85^\circ\text{C}$			200	
$I_{CC}$	Active supply current, IN pin	$\overline{CE} = \text{LO}$ , $V_{IN} = 6\text{ V}$ , no load on OUT pin, $V_{BAT} > V_{BAT(REG)}$ , (EN1, EN2) $\neq$ (HI, HI)			1.5	mA
<b>POWER PATH</b>						
$V_{DO(IN-OUT)}$	$V_{IN} - V_{OUT}$	$V_{IN} = 4.45\text{ V}$ , $I_{IN} = 500\text{ mA}$ , $V_{BAT} = 4.35\text{ V}$		150	237.5	mV
$V_{DO(BAT-OUT)}$	$V_{BAT} - V_{OUT}$	$I_{OUT} = 500\text{ mA}$ , $V_{IN} = 0\text{ V}$ , $V_{BAT} > 3\text{ V}$			62.5	mV
$V_{O(REG)}$	OUT pin voltage regulation	$V_{IN} > V_{OUT} + V_{DO(IN-OUT)}$	4.4	4.5	4.6	V
$I_{IN(max)}$	Maximum input current	EN1 = LO, EN2 = LO	90	95	100	mA
		EN1 = HI, EN2 = LO	450	475	500	
		EN1 = LO, EN2 = HI	$K_{ILIM}/R_{ILIM}$			A
$K_{ILIM}$	Maximum input current factor	$I_{LIM} = 200\text{ mA}$ to $500\text{ mA}$	1380	1530	1680	A $\Omega$
$I_{IN(max)}$	Programmable input current limit range	EN2 = HI, EN1 = LO, $R_{ILIM} = 3.1\text{ k}\Omega$ to $7.8\text{ k}\Omega$	200		500	mA
$V_{IN-DPM}$	Input voltage threshold when input current is reduced	EN2 = LO, EN1 = X	4.35	4.50	4.63	V
$V_{DPPM}$	Output voltage threshold when charging current is reduced		$V_{O(REG)} - 180\text{ mV}$	$V_{O(REG)} - 100\text{ mV}$	$V_{O(REG)} - 30\text{ mV}$	V
$V_{BSUP1}$	Enter battery supplement mode	$V_{BAT} = 3.6\text{ V}$ , $R_{ILIM} = 1.5\text{ k}\Omega$ , $R_{LOAD} = 10\ \Omega \rightarrow 2\ \Omega$		$V_{OUT} \leq V_{BAT} - 40\text{ mV}$		V
$V_{BSUP2}$	Exit battery supplement mode	$V_{BAT} = 3.6\text{ V}$ , $R_{ILIM} = 1.5\text{ k}\Omega$ , $R_{LOAD} = 2\ \Omega \rightarrow 10\ \Omega$		$V_{OUT} \geq V_{BAT} - 20\text{ mV}$		V
$V_{O(SC1)}$	Output short-circuit detection threshold, power-on	$V_{IN} > UVLO$ and $V_{IN} > V_{BAT} + V_{IN(DT)}$	0.8	0.9	1	V
$V_{O(SC2)}$	Output short-circuit detection threshold, supplement mode $V_{BAT} - V_{OUT} > V_{O(SC2)}$ indicates short circuit	$V_{IN} > UVLO$ and $V_{IN} > V_{BAT} + V_{IN(DT)}$	200	250	300	mV
$t_{DGL(SC2)}$	Deglintch time, supplement mode short circuit			250		$\mu\text{s}$
$t_{REC(SC2)}$	Recovery time, supplement mode short circuit			60		ms

## Electrical Characteristics (continued)

over operating free-air temperature range (unless otherwise noted)

PARAMETER		TEST CONDITIONS	MIN	TYP	MAX	UNIT
<b>BATTERY CHARGER</b>						
$I_{BAT(SC)}$	Source current for BAT pin short-circuit detection	$V_{BAT} = 1.5\text{ V}$	4	7.5	11	mA
$V_{BAT(SC)}$	BAT pin short-circuit detection threshold	$V_{BAT}$ rising	1.6	1.8	2	V
$V_{BAT(REG)}$	Battery charge voltage		4.306	4.35	4.394	V
$V_{LOWV}$	Precharge to fast-charge transition threshold	$V_{IN} > UVLO$ and $V_{IN} > V_{BAT} + V_{IN(DT)}$	2.9	3	3.1	V
$t_{DGL1(LOWV)}$	Deglintch time on precharge to fast-charge transition			25		ms
$t_{DGL2(LOWV)}$	Deglintch time on fast-charge to precharge transition			25		ms
$I_{CHG}$	Battery fast-charge current range	$V_{BAT(REG)} > V_{BAT} > V_{LOWV}$ , $V_{IN} = 5\text{ V}$ , $\overline{CE} = LO$ , $EN1 = LO$ , $EN2 = HI$	25		500	mA
	Battery fast-charge current	$\overline{CE} = LO$ , $EN1 = LO$ , $EN2 = HI$ , $V_{BAT} > V_{LOWV}$ , $V_{IN} = 5\text{ V}$ , $I_{IN(max)} > I_{CHG}$ , no load on OUT pin, thermal loop and DPM loop not active		$K_{ISET}/R_{ISET}$		A
$K_{ISET}$	Fast-charge current factor	$25\text{ mA} \leq I_{CHG} \leq 500\text{ mA}$	797	870	975	A $\Omega$
$K_{PRECHG}$	Precharge current factor	$2.5\text{ mA} \leq I_{PRECHG} \leq 50\text{ mA}$	70	88	106	A $\Omega$
$I_{TERM}$	Termination comparator threshold for internally set termination detection	$\overline{CE} = LO$ , $(EN1, EN2) \neq (LO, LO)$ , $V_{BAT} > V_{RCH}$ , $t < t_{MAXCH}$ , $V_{IN} = 5\text{ V}$ , DPM loop and thermal loop not active	$0.09 \times I_{CHG}$	$0.1 \times I_{CHG}$	$0.11 \times I_{CHG}$	A
		$\overline{CE} = LO$ , $(EN1, EN2) = (LO, LO)$ , $V_{BAT} > V_{RCH}$ , $t < t_{MAXCH}$ , $V_{IN} = 5\text{ V}$ , DPM loop and thermal loop not active	$0.027 \times I_{CHG}$	$0.033 \times I_{CHG}$	$0.040 \times I_{CHG}$	
$I_{TERM}$	Termination current threshold for programmable termination detection	$I_{TERM} = 0\%$ to $50\%$ of $I_{CHG}$		$K_{ITER} \times R_{ITER}/R_{ISET}$		A
$I_{BIAS(ITERM)}$	Current for external termination-setting resistor		72	75	78	$\mu\text{A}$
$K_{ITERM}$	K factor for termination detection threshold (externally set) (bq24232H)	$\overline{CE} = LO$ , $(EN1, EN2) \neq (LO, LO)$ , $V_{BAT} > V_{RCH}$ , $t < t_{MAXCH}$ , $V_{IN} = 5\text{ V}$ , DPM loop and thermal loop not active	0.024	0.030	0.036	A
		$\overline{CE} = LO$ , $(EN1, EN2) = (LO, LO)$ , $V_{BAT} > V_{RCH}$ , $t < t_{MAXCH}$ , $V_{IN} = 5\text{ V}$ , DPM loop and thermal loop not active	0.009	0.010	0.011	
$t_{DGL(TERM)}$	Deglintch time, termination detected			25		ms
$V_{RCH}$	Recharge detection threshold	$V_{IN} > UVLO$ and $V_{IN} > V_{BAT} + V_{IN(DT)}$	$V_{BAT(REG)} - 140\text{ mV}$	$V_{BAT(REG)} - 100\text{ mV}$	$V_{BAT(REG)} - 60\text{ mV}$	V
$t_{DGL(RCH)}$	Deglintch time, recharge threshold detected			62.5		ms
$t_{DGL(NO-IN)}$	Delay time, input power loss to charger turnoff	$V_{BAT} = 3.6\text{ V}$ . Time measured from $V_{IN}$ : $5\text{ V} \rightarrow 3\text{ V}$ 1- $\mu\text{s}$ fall time		20		ms
$I_{BAT(DET)}$	Sink current for battery detection	$V_{BAT} = 2.5\text{ V}$	5	7.5	10	mA
$t_{DET}$	Battery detection timer	BAT high or low		250		ms
<b>BATTERY CHARGING TIMERS</b>						
$t_{PRECHG}$	Precharge safety timer value	TMR = floating	1440	1800	2160	s
$t_{MAXCHG}$	Charge safety timer value	TMR = floating	14400	18000	21600	s
$t_{PRECHG}$	Precharge safety timer value	$18\text{ k}\Omega < R_{TMR} < 72\text{ k}\Omega$		$R_{TMR} \times K_{TMR}$		s
$t_{MAXCHG}$	Charge safety timer value	$18\text{ k}\Omega < R_{TMR} < 72\text{ k}\Omega$		$10 \times R_{TMR} \times K_{TMR}$		s
$K_{TMR}$	Timer factor		30	40	50	s/k $\Omega$

## Electrical Characteristics (continued)

over operating free-air temperature range (unless otherwise noted)

PARAMETER		TEST CONDITIONS	MIN	TYP	MAX	UNIT
<b>BATTERY-PACK NTC MONITOR<sup>(1)</sup></b>						
$I_{NTC}$	NTC bias current	$V_{IN} > UVLO$ and $V_{IN} > V_{BAT} + V_{IN(DT)}$	72	75	78	$\mu A$
$V_{HOT}$	High-temperature trip point	Battery charging, $V_{TS}$ Falling	270	300	330	mV
$V_{HYS(HOT)}$	Hysteresis on high trip point	Battery charging, $V_{TS}$ Rising from $V_{HOT}$		30		mV
$V_{COLD}$	Low-temperature trip point	Battery charging, $V_{TS}$ Rising	2000	2100	2200	mV
$V_{HYS(COLD)}$	Hysteresis on low trip point	Battery charging, $V_{TS}$ Falling from $V_{COLD}$		300		mV
$t_{DGL(TS)}$	Deglintch time, pack temperature fault detection	Battery charging, $V_{TS}$ Falling		50		ms
$V_{DIS(TS)}$	TS function disable threshold	TS unconnected (applies with TD pin on bq24230H)		$V_{IN}-200$ mV		V
<b>THERMAL REGULATION</b>						
$T_{J(REG)}$	Temperature regulation limit			125		$^{\circ}C$
$T_{J(OFF)}$	Thermal shutdown temperature	$T_J$ rising		155		$^{\circ}C$
$T_{J(OFF-HYS)}$	Thermal shutdown hysteresis			20		$^{\circ}C$
<b>LOGIC LEVELS ON EN1, EN2, <math>\overline{CE}</math>, TD</b>						
$V_{IL}$	Logic LOW input voltage		0		0.4	V
$V_{IH}$	Logic HIGH input voltage		1.4		6.0	V
$I_{IL}$	Input sink current	$V_{IL} = 0$ V			1	$\mu A$
$I_{IH}$	Input source current	$V_{IH} = 1.4$ V			10	$\mu A$
<b>LOGIC LEVELS ON <math>\overline{PGOOD}</math>, <math>\overline{CHG}</math></b>						
$V_{OL}$	Output LOW voltage	$I_{SINK} = 5$ mA			0.4	V

- (1) These numbers set trip points of 0 $^{\circ}C$  and 50 $^{\circ}C$  while charging, with 3 $^{\circ}C$  hysteresis on the trip points, with a Vishay Type 2 curve NTC with an R25 of 10 k $\Omega$ .



## 7.6 Typical Characteristics

Typical Application Circuit, EN1 = 0, EN2 = 1,  $T_A = 25^\circ\text{C}$ , unless otherwise noted.

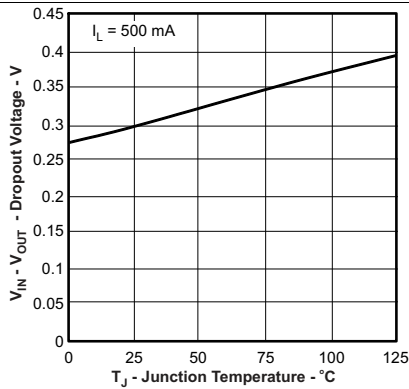

Figure 1. Dropout Voltage vs Temperature

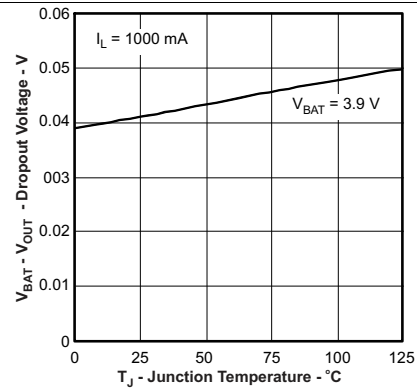

Figure 2. Dropout Voltage vs Temperature

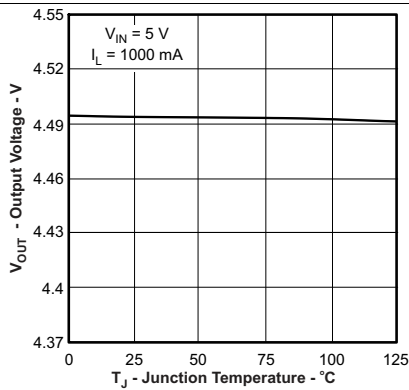

Figure 3. Output Voltage vs Temperature

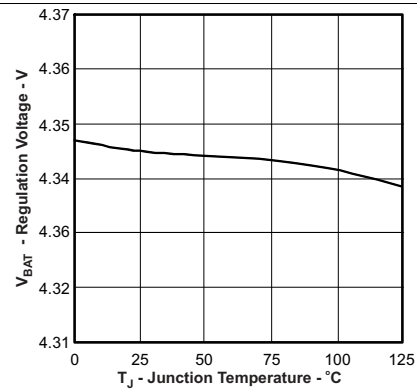

Figure 4. Output Regulation Voltage vs Temperature

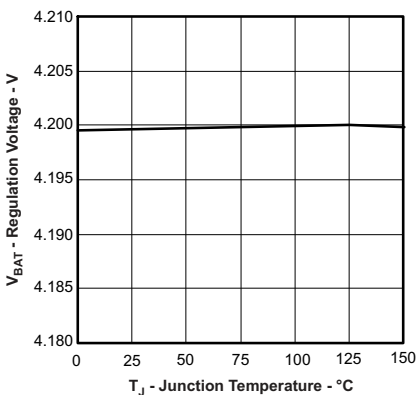

Figure 5. Battery Regulation Voltage vs Temperature

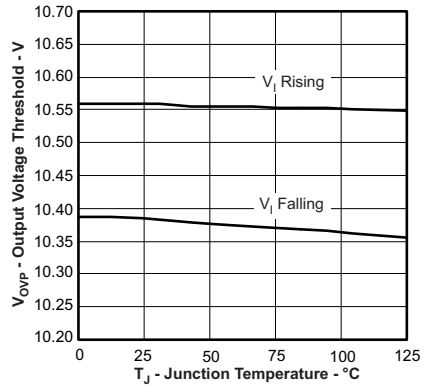
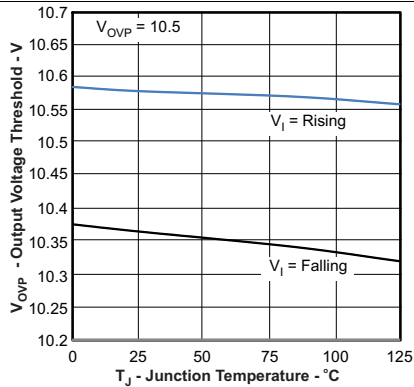

Figure 6. Output Voltage Threshold vs Temperature (bq24230H)

## Typical Characteristics (continued)

Typical Application Circuit, EN1 = 0, EN2 = 1,  $T_A = 25^\circ\text{C}$ , unless otherwise noted.



**Figure 7. Output Voltage Threshold vs Temperature (bq24232H)**

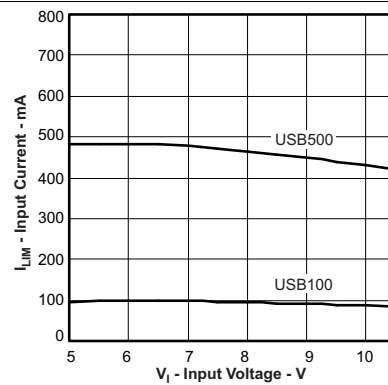

**Figure 8. Input Current Limit Threshold vs Input Voltage**

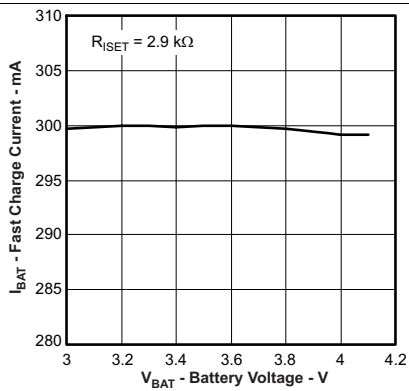

**Figure 9. Fast-Charge Current vs Battery Voltage**

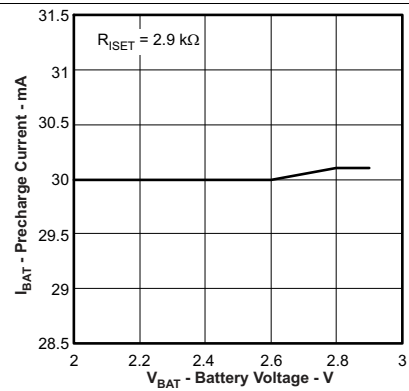

**Figure 10. Precharge Current vs Battery Voltage**

## 8 Detailed Description

### 8.1 Overview

The bq2423xH devices are integrated Li-ion linear chargers and system power-path management devices targeted at space-limited portable applications. The device powers the system while simultaneously and independently charging the battery. This feature reduces the number of charge and discharge cycles on the battery, allows for proper charge termination, and enables the system to run with a defective or absent battery pack. This feature also allows instant system turnon even with a totally discharged battery. The input power source for charging the battery and running the system can be an AC adapter or a USB port. The devices feature dynamic power-path management (DPPM), which shares the source current between the system and battery charging and automatically reduces the charging current if the system load increases. When charging from a USB port, the input dynamic power management ( $V_{IN}$ -DPM) circuit reduces the input current limit if the input voltage falls below a threshold, thus preventing the USB port from crashing. The power-path architecture also permits the battery to supplement the system current requirements when the adapter cannot deliver the peak system currents.

## 8.2 Functional Block Diagram

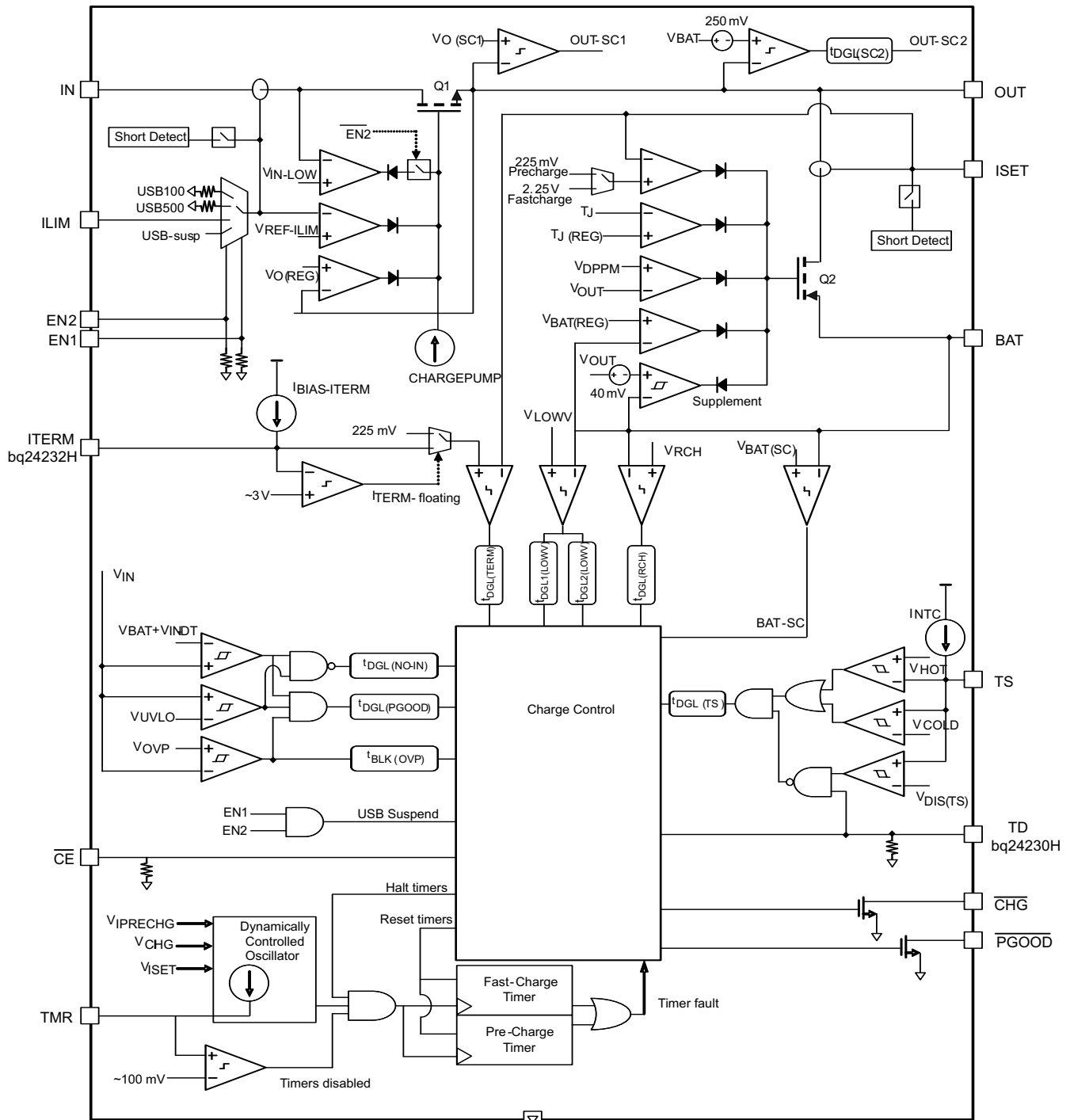

## 8.3 Feature Description

### 8.3.1 Undervoltage Lockout

The bq2423xH family remains in power-down mode when the input voltage at the IN pin is below the undervoltage lockout (UVLO) threshold.

During the power-down mode, the host commands at the control inputs ( $\overline{\text{CE}}$ , EN1 and EN2) are ignored. The Q1 FET connected between IN and OUT pins is off, and the status outputs  $\overline{\text{CHG}}$  and  $\overline{\text{PGOOD}}$  are high impedance. The Q2 FET that connects BAT to OUT is ON. During power-down mode, the  $V_{\text{OUT(SC2)}}$  circuitry is active and monitors for overload conditions on OUT.

### 8.3.2 Power On

When  $V_{\text{IN}}$  exceeds the UVLO threshold, the bq2423xH powers up. While  $V_{\text{IN}}$  is below  $V_{\text{BAT}} + V_{\text{IN(DT)}}$ , the host commands at the control inputs ( $\overline{\text{CE}}$ , EN1, and EN2) are ignored. The Q1 FET connected between IN and OUT pins is off, and the status outputs  $\overline{\text{CHG}}$  and  $\overline{\text{PGOOD}}$  are high impedance. The Q2 FET that connects BAT to OUT is ON. During this mode, the  $V_{\text{OUT(SC2)}}$  circuitry is active and monitors for overload conditions on OUT.

When  $V_{\text{IN}}$  rises above  $V_{\text{BAT}} + V_{\text{IN(DT)}}$ ,  $\overline{\text{PGOOD}}$  is low to indicate that the valid power status and the  $\overline{\text{CE}}$ , EN1, and EN2 inputs are read. The device enters standby mode whenever (EN1, EN2) = (1, 1) or if an input overvoltage condition occurs. In standby mode, Q1 is OFF and Q2 is ON. (If SYSOFF is high, FET Q2 is off). During standby mode, the  $V_{\text{OUT(SC2)}}$  circuitry is active and monitors for overload conditions on OUT.

When the input voltage at IN is within the valid range:  $V_{\text{IN}} > \text{UVLO}$  **AND**  $V_{\text{IN}} > V_{\text{BAT}} + V_{\text{IN(DT)}}$  **AND**  $V_{\text{IN}} < V_{\text{OVP}}$ , and the EN1 and EN2 pins indicate that the USB suspend mode is not enabled [(EN1, EN2)  $\neq$  (HI, HI)], all internal timers and other circuit blocks are activated. The device checks for short circuits at the ISET and ILIM pins. If no short conditions exists, the device switches on the input FET Q1 with a 100-mA current limit to check for a short circuit at OUT. If  $V_{\text{OUT}}$  rises above  $V_{\text{SC}}$ , the FET Q1 switches to the current-limit threshold set by EN1, EN2, and  $R_{\text{ILIM}}$  and the device enters normal operation where the system is powered by the input source (Q1 is on), and the device continuously monitors the status of  $\overline{\text{CE}}$ , EN1, and EN2 as well as the input voltage conditions.

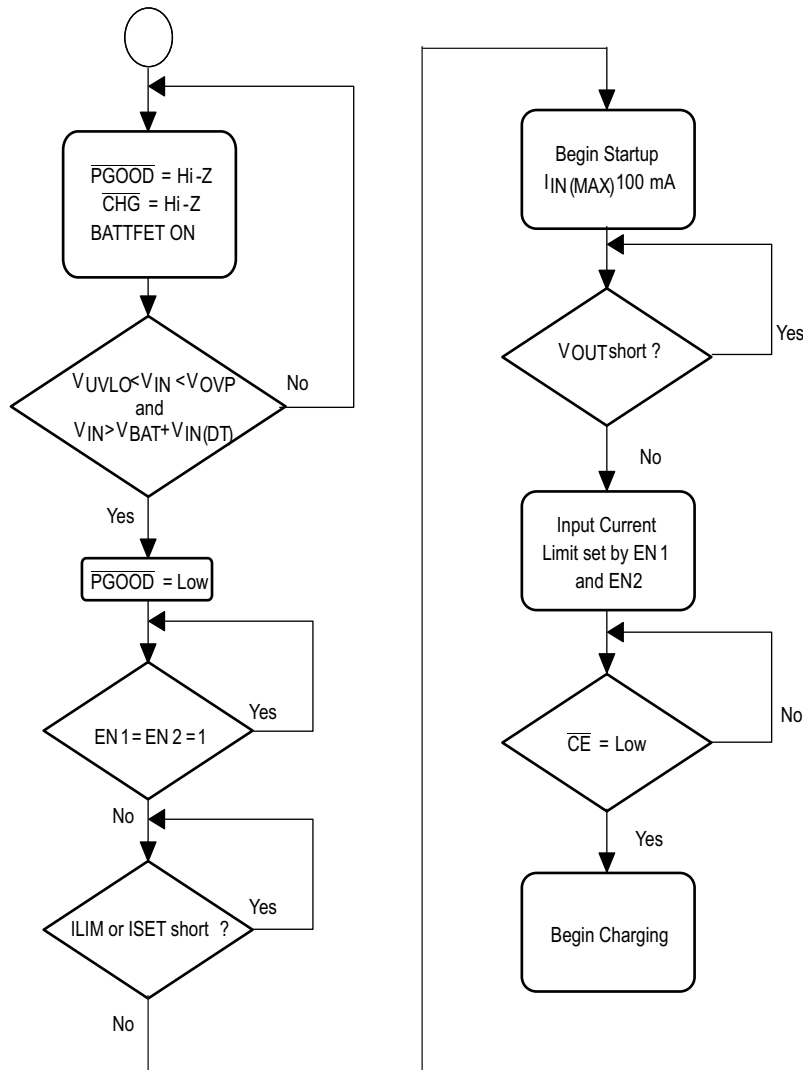
**Feature Description (continued)**

**Figure 11. Start-up Flow Diagram**
**8.3.3 Power-Path Management**

The bq2423xH features an OUT output that powers the external load connected to the battery. This output is active whenever a source is connected to IN or BAT. The following sections discuss the behavior of OUT with a source connected to IN to charge the battery and a battery source only.

**8.3.3.1 Input Source Connected – Adapter or USB**

With a source connected, the power-path management circuitry of the bq2423xH monitors the input current continuously. The OUT output is regulated to a fixed voltage ( $V_{O(REG)}$ ). The current into IN is shared between charging the battery and powering the system load at OUT. The bq2423xH has internal selectable current limits of 100 mA (USB100) and 500 mA (USB500) for charging from USB ports, as well as a resistor-programmable input current limit.

**Feature Description (continued)**

The bq2423xH is USB-IF compliant for the inrush current testing. The USB specification allows up to 10 μF to be hard-started, which establishes 50 μC as the maximum inrush charge value when exceeding 100 mA. The input current limit for the bq2423xH prevents the input current from exceeding this limit, even with system capacitances greater than 10 μF. The input capacitance to the device must be selected small enough to prevent a violation (<10 μF), as this current is not limited. Figure 12 demonstrates the start-up of the bq2423xH and compares it to the USB specification.

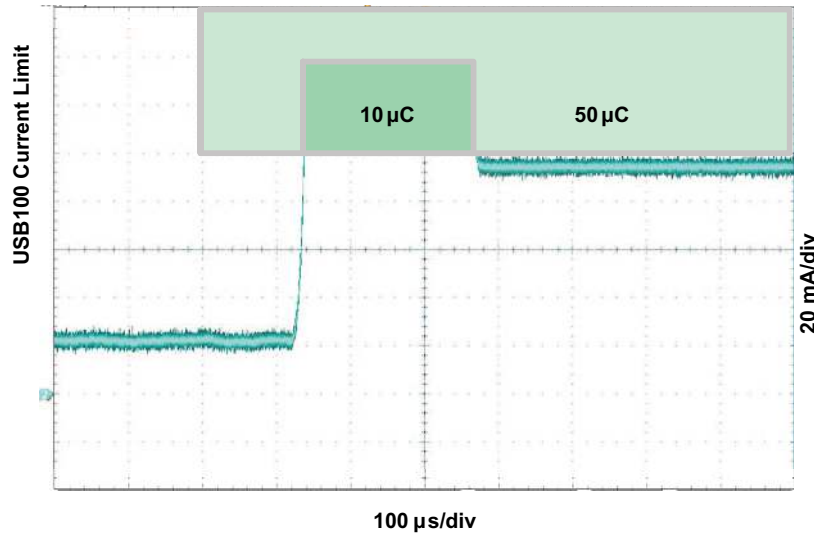

**Figure 12. USB-IF Inrush Current Test**

The input current limit selection is controlled by the state of the EN1 and EN2 pins as shown in Table 1. When using the resistor-programmable current limit, the input current limit is set by the value of the resistor connected from the ILIM pin to VSS and is given by the equation:

$$I_{IN-MAX} = K_{ILIM}/R_{ILIM}$$

The input current limit is adjustable up to 500 mA. The valid resistor range is 3.2 kΩ to 8 kΩ.

When the IN source is connected, priority is given to the system load. The DPPM and Battery Supplement modes are used to maintain the system load. Figure 13 illustrates examples of the DPPM and supplement modes. These modes are explained in detail in the following sections.

**Table 1. EN1/EN2 Settings**

EN2	EN1	MAXIMUM INPUT CURRENT INTO IN PIN
0	0	100 mA. USB100 mode
0	1	500 mA. USB500 mode
1	0	Set by an external resistor from ILIM to VSS
1	1	Standby (USB suspend mode)

**8.3.3.1.1 Input DPM Mode, V<sub>IN</sub>-DPM**

The bq2423xH uses the V<sub>IN</sub>-DPM mode for operation from current-limited USB ports. When EN1 and EN2 are configured for USB100 (EN2=0, EN1=0) or USB500 (EN2=0, EN2=1) modes, the input voltage is monitored. If V<sub>IN</sub> falls to V<sub>IN-DPM</sub>, the input current limit is reduced to prevent the input voltage from falling further. This prevents the bq2423xH from crashing poorly designed or incorrectly configured USB sources.

### 8.3.3.1.2 DPPM Mode

When the sum of the charging and system load currents exceeds the preset maximum input current (programmed with EN1, EN2, and ILIM pins), the voltage at OUT decreases. Once the voltage on the OUT pin falls to  $V_{DPPM}$ , the bq2423xH enters DPPM mode. In this mode, the charging current is reduced as the OUT current goes up in order to maintain the system output. Battery termination is disabled while in DPPM mode.

### 8.3.3.1.3 Battery Supplement Mode

While in DPPM mode, if the charging current falls to zero and the system load current increases beyond the programmed input current limit, the voltage at OUT reduces further. When the OUT voltage drops below the battery voltage by  $V_{BSUP1}$ , the battery supplements the system load. The battery stops supplementing the system load when the voltage on the OUT pin rises above the battery voltage by  $V_{BSUP2}$ .

During supplement mode, the battery supplement current is not regulated; however, a short-circuit protection circuit is built in. If during battery supplement mode, the voltage at OUT drops 250 mV below the BAT voltage, the OUT output is turned off if the overload exists after  $t_{DGL(SC2)}$ . The short-circuit recovery timer then starts counting. After  $t_{REC(SC2)}$ , OUT turns on and attempts to restart. If the short circuit remains, OUT is turned off and the counter restarts. Battery termination is disabled while in supplement mode.

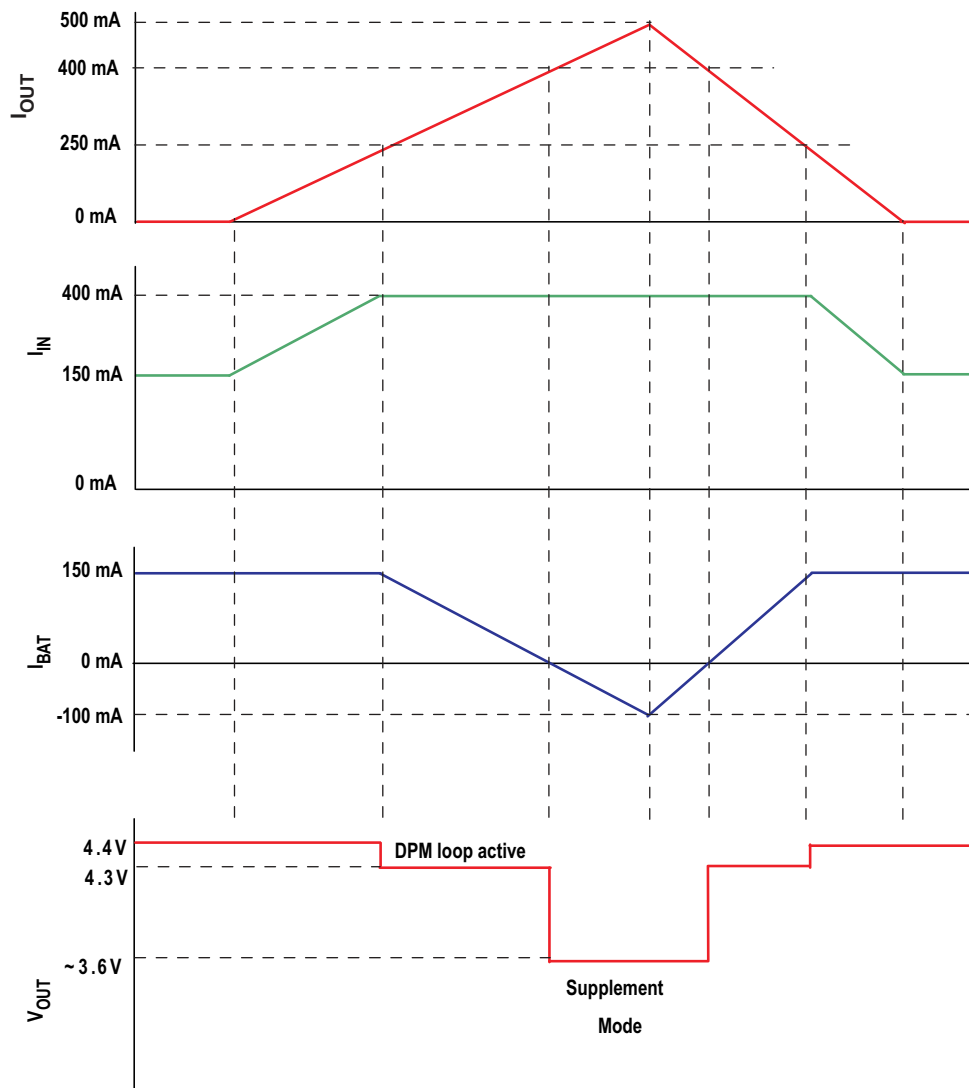

**Figure 13. bq2423xH DPPM and Battery Supplement Modes**  
 ( $V_{OREG} = 4.4\text{ V}$ ,  $V_{BAT} = 3.6\text{ V}$ ,  $I_{LIM} = 400\text{ mA}$ ,  $I_{CHG} = 150\text{ mA}$ )



### 8.3.3.2 Input Source Not Connected

When no source is connected to the IN input, OUT is powered strictly from the battery. During this mode, the current into OUT is unregulated, similar to *Battery Supplement Mode*; however, the short-circuit circuitry is active. If the OUT voltage falls below the BAT voltage by 250 mV for longer than  $t_{DGL(SC2)}$ , OUT is turned off. The short-circuit recovery timer then starts counting. After  $t_{REC(SC2)}$ , OUT turns on and attempts to restart. If the short-circuit remains, OUT is turned off and the counter restarts. This ON/OFF cycle continues until the overload condition is removed.

### 8.3.4 Battery Charging

Set  $\overline{CE}$  low to initiate battery charging. First, the device checks for a short circuit on the BAT pin by sourcing  $I_{BAT(SC)}$  to the battery and monitoring the voltage. When the BAT voltage exceeds  $V_{BAT(SC)}$ , the battery charging continues. The battery is charged in three phases: conditioning precharge, constant-current fast charge (current regulation), and a constant-voltage tapering (voltage regulation). In all charge phases, an internal control loop monitors the IC junction temperature and reduces the charge current if an internal temperature threshold is exceeded.

Figure 14 illustrates a normal Li-ion charge cycle using the bq2423xH:

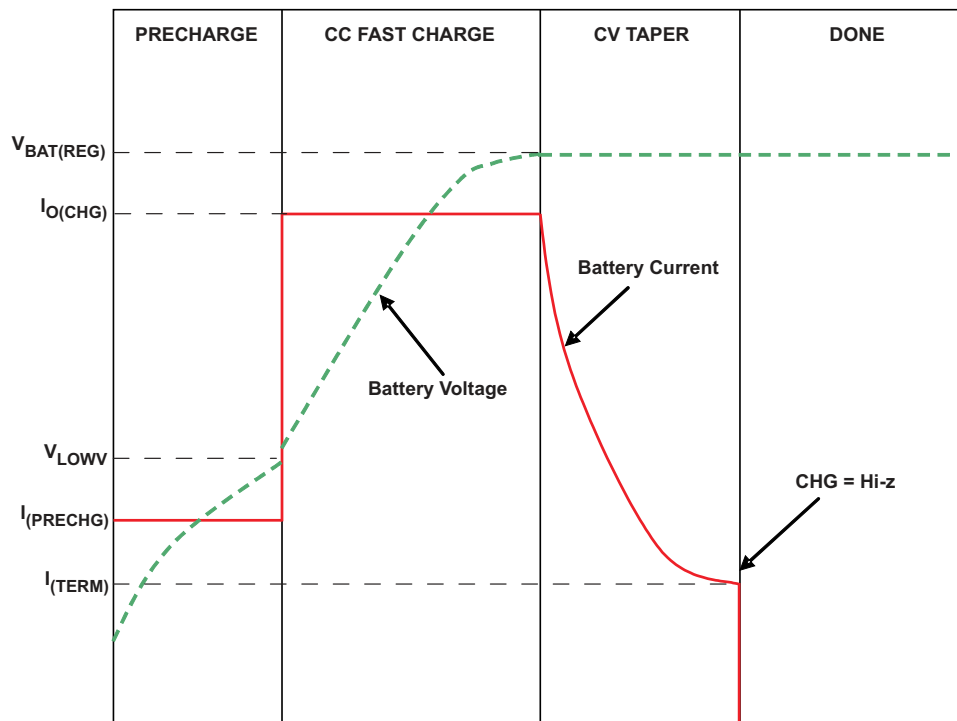

Figure 14. Normal Li-ion Charge Cycle

In the precharge phase, the battery is charged with the precharge current ( $I_{PRECHG}$ ). Once the battery voltage crosses the  $V_{LOWV}$  threshold, the battery is charged with the fast-charge current ( $I_{CHG}$ ). As the battery voltage reaches  $V_{BAT(REG)}$ , the battery is held at a constant voltage of  $V_{BAT(REG)}$  and the charge current tapers off as the battery approaches full charge. When the battery current reaches  $I_{TERM}$ , the  $\overline{CHG}$  pin indicates *charging done* by going high impedance.

$$I_{PRECHG} = K_{PRECHG}/R_{ISET} \quad (1)$$

Termination detection is disabled whenever the charge rate is reduced because of the actions of the thermal loop, the DPPM loop, or the  $V_{IN(LOW)}$  loop.

The value of the fast-charge current is set by the resistor connected from the ISET pin to VSS, and is given by Equation 2:

$$I_{CHG} = K_{ISET}/R_{ISET} \quad (2)$$

The charge current limit is adjustable from 25 mA to 500 mA. The valid resistor range is 1.74 kΩ to 34.8 kΩ. If  $I_{CHG}$  is programmed as greater than the input current limit, the battery does not charge at the rate of  $I_{CHG}$ , but at the slower rate of  $I_{IN(MAX)}$  (minus the load current on the OUT pin, if any). In this case, the charger timers are proportionately slowed down.

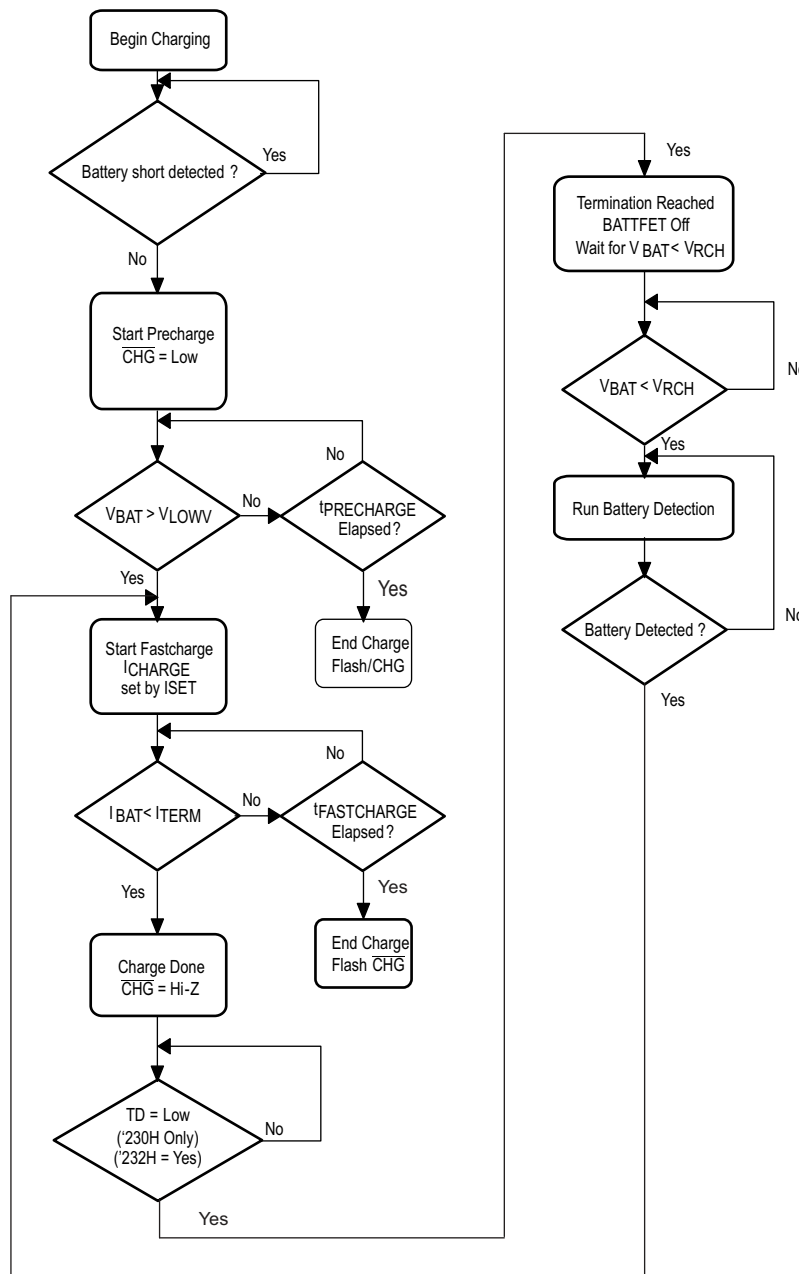

**Figure 15. Battery Charging Flow Diagram**

### 8.3.4.1 Charge Current Translator

When the charger is enabled, internal circuits generate a current proportional to the charge current at the ISET input. The current out of ISET is 1/400 ( $\pm 10\%$ ) of the charge current. This current, when applied to the external charge current programming resistor,  $R_{ISET}$ , generates an analog voltage that can be monitored by an external host to calculate the current sourced from BAT.

$$V_{ISET} = (I_{CHARGE} / 400) \times R_{ISET} \quad (3)$$

### 8.3.4.2 Battery Detection and Recharge

The bq2423xH automatically detects if a battery is connected or removed. Once a charge cycle is complete, the battery voltage is monitored. When the battery voltage falls below  $V_{RCH}$ , the battery detection routine is run. The detection routine first applies  $I_{BAT(DET)}$  for  $t_{DET}$  to see if  $V_{BAT}$  drops below  $V_{LOWV}$ . If not, it indicates that the battery is still connected, but has discharged. If  $\overline{CE}$  is low, the charger is turned on again to top off the battery. During this recharge cycle, the  $\overline{CHG}$  output remains high-impedance as recharge cycles are not indicated by the  $\overline{CHG}$  pin. If the BAT voltage falls below  $V_{LOWV}$  during the battery detection test, it indicates that the battery has been removed or the protector is open. Next, the precharge current is applied for  $t_{DET}$  to close the protector if possible. If the battery voltage does not rise above  $V_{RCH}$ , it indicates that the protector is closed, or a battery has been inserted, and a new charge cycle begins. If the voltage rises above  $V_{RCH}$ , the battery is determined missing and the detection routine continues. The battery detection runs until a battery is detected.

### 8.3.4.3 Termination Disable (TD Input, bq24230H)

The bq24230H contains a TD input that allows termination to be enabled/disabled. Connect TD to a logic high to disable charge termination. When termination is disabled, the device goes through the precharge, fast-charge, and CV phases, then remains in the CV phase. During the CV phase, the charger maintains the output voltage at BAT equal to  $V_{BAT(REG)}$ , and charging current does not terminate. BAT sources currents up to  $I_{CHG}$  or  $I_{IN-MAX}$ , whichever is less. Battery detection is not performed. The  $\overline{CHG}$  output is high impedance once the current falls below  $I_{TERM}$  and does not go low until the input power or  $\overline{CE}$  are toggled. When termination is disabled, the precharge and fast-charge safety timers are also disabled. Battery pack temperature sensing (TS pin functionality) is also disabled if the TD pin is high and the TS pin is unconnected.

### 8.3.4.4 Adjustable Termination Threshold (ITERM Input, bq24232H)

The termination current threshold for the bq24232H is user-programmable. Set the termination current by connecting a resistor from ITERM to VSS. For USB100, mode (EN1 = EN2 = VSS), the termination current value is calculated as:

$$I_{TERM} = 0.01 \times R_{ITERM} / R_{ISET} \quad (4)$$

In the other input current limit modes (EN1  $\neq$  EN2), the termination current value is calculated as:

$$I_{TERM} = 0.03 \times R_{ITERM} / R_{ISET} \quad (5)$$

The termination current is programmable up to 50% of the fast-charge current. The  $R_{ITERM}$  resistor must be less than 15 k $\Omega$ . Leave ITERM unconnected to select the default internally set termination current.

### 8.3.4.5 Dynamic Charge Timers (TMR Input)

The bq2423xH devices contain internal safety timers for the precharge and fast-charge phases to prevent potential damage to the battery and the system. The timers begin at the start of the respective charge cycles. The timer values are programmed by connecting a resistor from TMR to VSS. The resistor value is calculated using the following equation:

$$t_{PRECHG} = K_{TMR} \times R_{TMR} \quad (6)$$

$$t_{MAXCHG} = 10 \times K_{TMR} \times R_{TMR} \quad (7)$$

Leave TMR unconnected to select the internal default timers. Disable the timers by connecting TMR to VSS. Reset the timers by toggling the CE pin, or by toggling EN1, EN2 pin to put the device in and out of USB suspend mode (EN1 = HI, EN2 = HI).

Timers are suspended when the device is in thermal shutdown, and the timers are slowed proportionally to the charge current when the device enters thermal regulation. For the bq24230H, the timers are disabled when TD is connected to a high logic level.

During the fast-charge phase, several events increase the timer durations.

1. The system load current activates the DPPM loop which reduces the available charging current
2. The input current is reduced because the input voltage has fallen to  $V_{IN(LOW)}$
3. The device has entered thermal regulation because the IC junction temperature has exceeded  $T_{J(REG)}$

During each of these events, the internal timers are slowed down proportionately to the reduction in charging current. For example, if the charging current is reduced by half for 2 minutes, the timer clock is reduced to half the frequency and the counter counts half as fast resulting in only 1 minute of counted time.

### 8.3.4.6 Status Indicators ( $\overline{\text{PGOOD}}$ , $\overline{\text{CHG}}$ )

The bq2423xH contains two open-drain outputs that signal its status. The  $\overline{\text{PGOOD}}$  output signals when a valid input source is connected.  $\overline{\text{PGOOD}}$  is low when  $(V_{\text{BAT}} + V_{\text{IN(DT)}}) < V_{\text{IN}} < V_{\text{OVP}}$ . When the input voltage is outside of this range,  $\overline{\text{PGOOD}}$  is high impedance.

The  $\overline{\text{CHG}}$  output signals when a new charge cycle is initiated. After a charge cycle is initiated,  $\overline{\text{CHG}}$  goes low once the battery is above the short-circuit threshold.  $\overline{\text{CHG}}$  goes high impedance once the charge current falls below  $I_{\text{TERM}}$ .  $\overline{\text{CHG}}$  remains high impedance until the input power is removed and reconnected or the  $\overline{\text{CE}}$  pin is toggled. It does not signal subsequent recharge cycles.

**Table 2.  $\overline{\text{PGOOD}}$  Status Indicator**

INPUT STATE	$\overline{\text{PGOOD}}$ OUTPUT
$V_{\text{IN}} < V_{\text{UVLO}}$	High-impedance
$V_{\text{UVLO}} < V_{\text{IN}} < V_{\text{IN(DT)}} + V_{\text{BAT}}$	High-impedance
$V_{\text{IN(DT)}} + V_{\text{BAT}} < V_{\text{IN}} < V_{\text{OVP}}$	Low
$V_{\text{IN}} > V_{\text{OVP}}$	High-impedance

**Table 3.  $\overline{\text{CHG}}$  Status Indicator**

CHARGE STATE	$\overline{\text{CHG}}$ OUTPUT
Charging	Low (first charge cycle)
Charging terminated	High-impedance until power or $\overline{\text{CE}}$ is toggled
Recharging after termination	High-impedance
Charging suspended by thermal loop	Low (first charge cycle)
Safety timers expired	Flashing at 2Hz
IC disabled or no valid input power	High-impedance

#### 8.3.4.6.1 Timer Fault

If the precharge timer expires before the battery voltage reaches  $V_{\text{LOWV}}$ , the bq2423xH indicates a fault condition. Additionally, if the battery current does not fall to  $I_{\text{TERM}}$  before the fast-charge timer expires, a fault is indicated. The  $\overline{\text{CHG}}$  output flashes at approximately 2 Hz to indicate a fault condition.

#### 8.3.4.7 Thermal Regulation and Thermal Shutdown

The bq2423xH contain a thermal regulation loop that monitors the die temperature. If the die temperature exceeds  $T_{\text{J(REG)}}$ , the device automatically reduces the charging current to prevent the die temperature from increasing further. In some cases, the die temperature continues to rise despite the operation of the thermal loop, particularly under high  $V_{\text{IN}}$  and heavy OUT system load conditions. Under these conditions, if the die temperature increases to  $T_{\text{J(OFF)}}$ , the input FET Q1 is turned OFF. FET Q2 is turned ON to ensure that the battery still powers the load on OUT. Once the device die temperature cools by  $T_{\text{J(OFF-HYS)}}$ , the input FET Q1 is turned on and the device returns to thermal regulation. Continuous overtemperature conditions result in a hiccup mode. Safety timers are slowed proportionally to the charge current in thermal regulation. Battery termination is disabled during thermal regulation and thermal shutdown.

Note that this feature monitors the die temperature of the bq2423xH. This is not synonymous with ambient temperature. Self-heating exists due to the power dissipated in the IC because of the linear nature of the battery charging algorithm and the LDO mode for OUT.

A modified charge cycle with the thermal loop active is shown in [Figure 16](#):

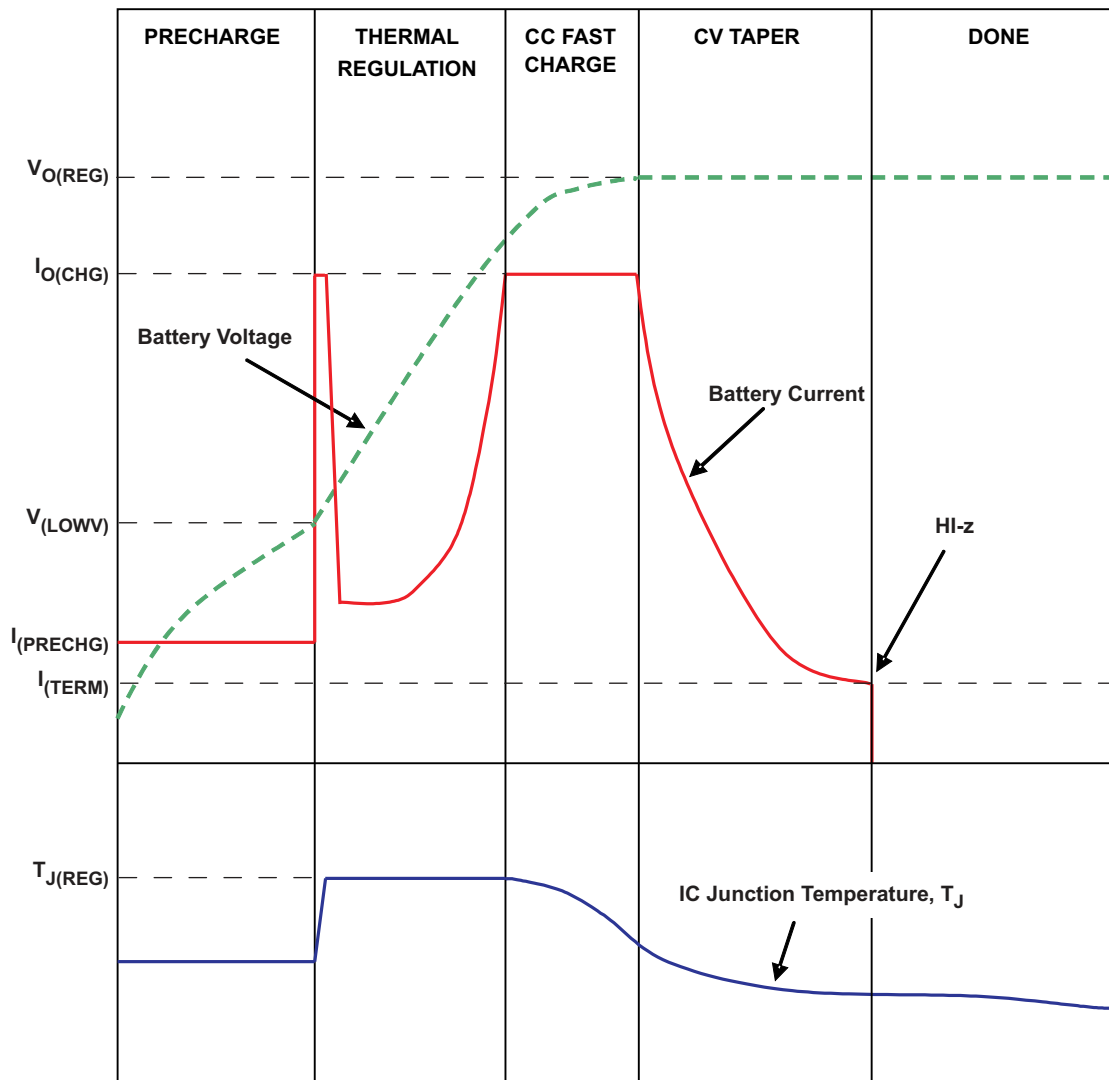

Figure 16. Modified Charge Cycle With Thermal Loop Active

### 8.3.5 Battery Pack Temperature Monitoring

The bq2423xH features an external battery pack temperature monitoring input. The TS input connects to the NTC resistor in the battery pack to monitor battery temperature and prevent dangerous overtemperature conditions.

During charging,  $I_{NTC}$  is sourced to TS and the voltage at TS is continuously monitored. If, at any time, the voltage at TS is outside of the operating range ( $V_{COLD}$  to  $V_{HOT}$ ), charging is suspended. The timers maintain their values but suspend counting. When the voltage measured at TS returns to within the operation window, charging is resumed and the timers continue counting. When charging is suspended due to a battery pack temperature fault, the CHG pin remains low and continues to indicate charging.

For the bq24230H, battery pack temperature sensing is disabled when termination is disabled ( $TD = High$ ) and the voltage at TS is greater than  $V_{DIS(TS)}$ . The battery pack temperature monitoring is disabled in all devices by connecting a 10-k $\Omega$  resistor from TS to VSS.

The allowed temperature range for a 103AT-2 type thermistor is 0°C to 50°C. However, the user can increase the range by adding two external resistors. See [Figure 17](#) for the circuit. The values for  $R_S$  and  $R_P$  are calculated using the following equations:

$$R_S = \frac{-(R_{TH} + R_{TC}) \pm \sqrt{\left( (R_{TH} + R_{TC})^2 - 4 \left\{ R_{TH} \times R_{TC} + \frac{V_H \times V_C}{(V_H - V_C) \times I_{TS}} \times (R_{TC} - R_{TH}) \right\} \right)}}{2} \quad (8)$$

$$R_P = \frac{V_H \times (R_{TH} + R_S)}{I_{TS} \times (R_{TH} + R_S) - V_H} \quad (9)$$

Where:

- $R_{TH}$ : Thermistor Hot Trip Value found in thermistor data sheet
- $R_{TC}$ : Thermistor Cold Trip Value found in thermistor data sheet
- $V_H$ : IC's Hot Trip Threshold = 0.3V nominal
- $V_C$ : IC's Cold Trip Threshold = 2.1V nominal
- $I_{TS}$ : IC's Output Current Bias = 75μA nominal
- NTC Thermistor Semitec 103AT-4

$R_S$  and  $R_P$  1% values were chosen closest to calculated values

COLD TEMP RESISTANCE AND TRIP THRESHOLD; Ω (°C)	HOT TEMP RESISTANCE AND TRIP THRESHOLD; Ω (°C)	EXTERNAL BIAS RESISTOR, $R_S$ (Ω)	EXTERNAL BIAS RESISTOR, $R_P$ (Ω)
28000 (-0.6)	4000 (51)	0	∞
28480 (-1)	3536 (55)	487	845000
28480 (-1)	3021 (60)	1000	549000
33890 (-5)	4026 (51)	76.8	158000
33890 (-5)	3536 (55)	576	150000
33890 (-5)	3021 (60)	1100	140000

RHOT and RCOLD are the thermistor resistance at the desired hot and cold temperatures, respectively. The temperature window cannot be tightened more than the thermistor connected to TS, it can only be extended.

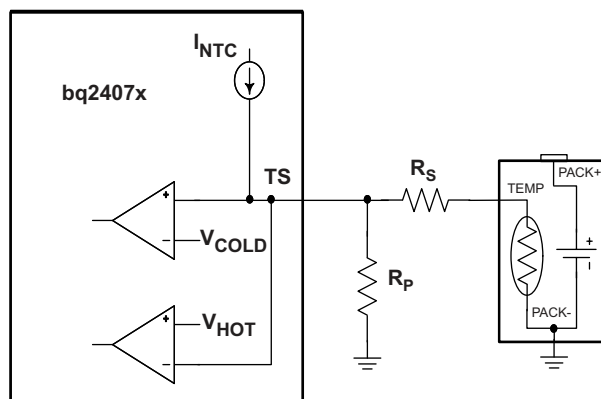

**Figure 17. Extended TS Temperature Thresholds**

## 8.4 Device Functional Modes

### 8.4.1 Explanation of Deglitch Times and Comparator Hysteresis

Figures not to scale

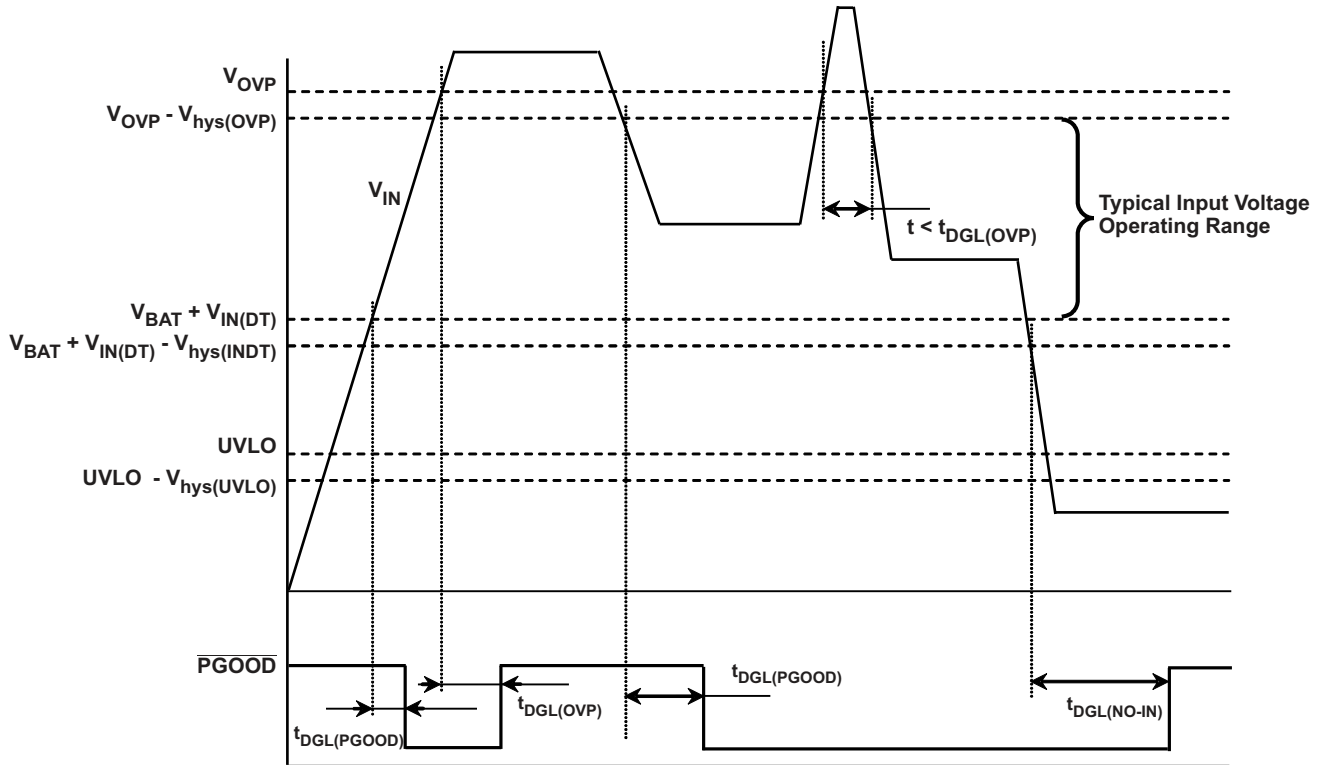

Figure 18. Power Up, Power Down

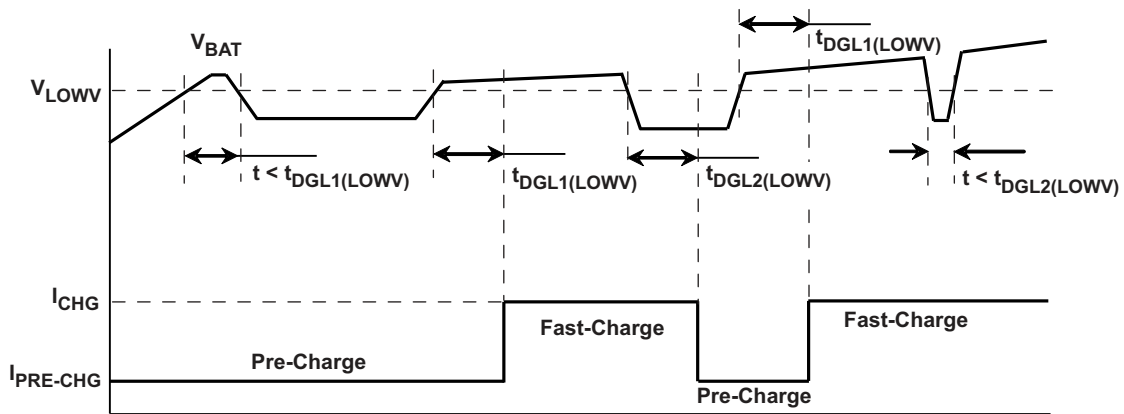
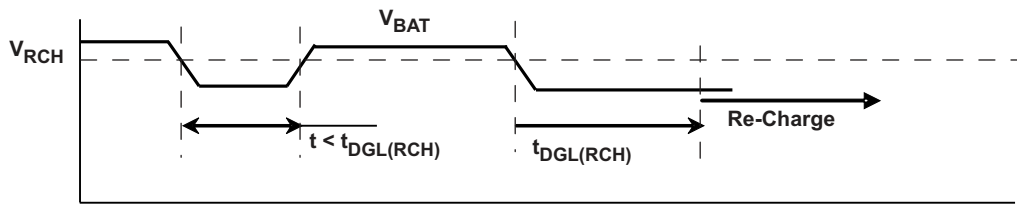
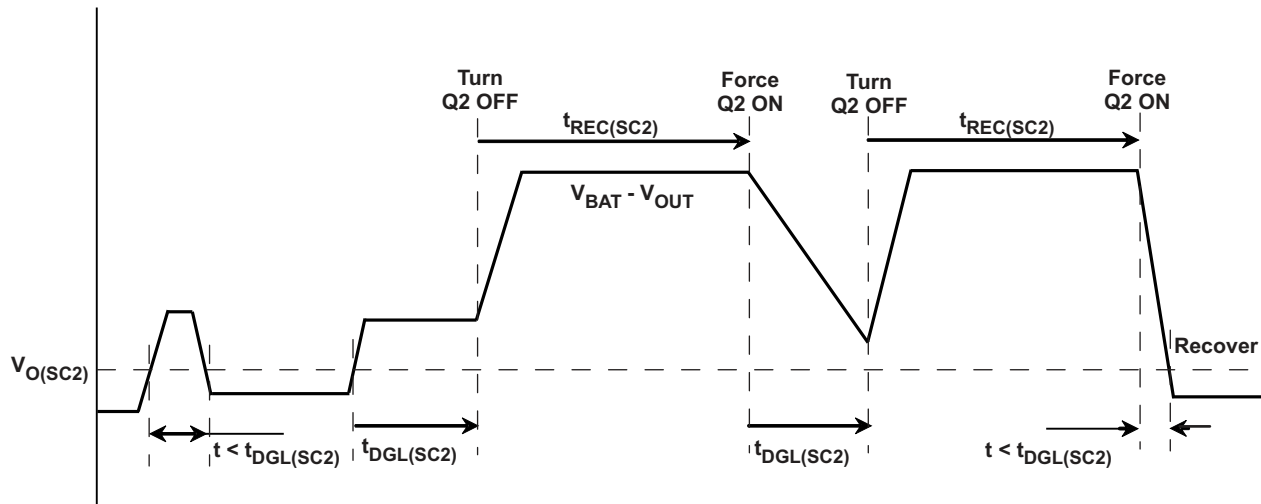
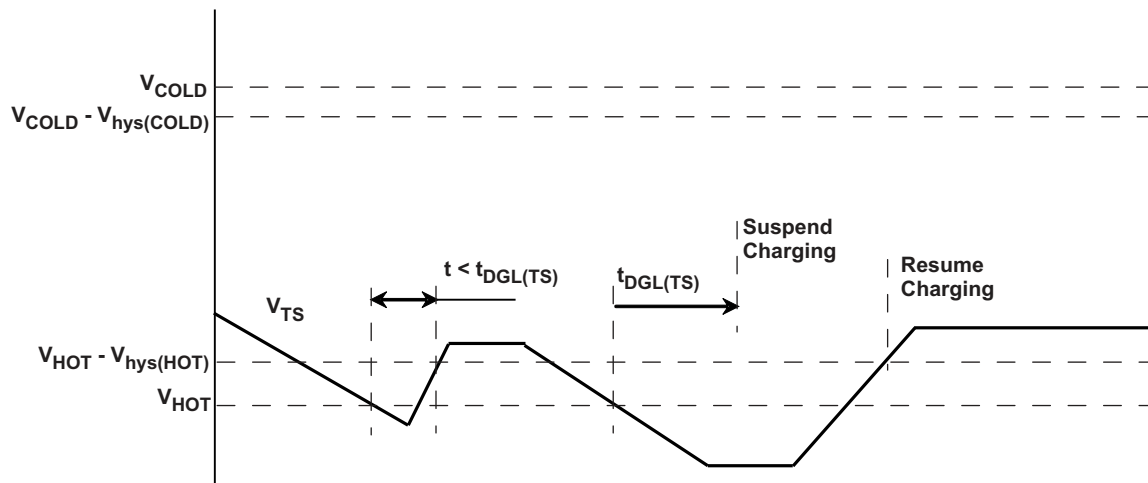

Figure 19. Precharge to Fast-Charge, Fast- to Precharge Transition –  $t_{DGL1(LOWV)}$ ,  $t_{DGL2(LOWV)}$

**Device Functional Modes (continued)**

**Figure 20. Recharge –  $t_{DGL(RCH)}$** 

**Figure 21. OUT Short-Circuit – Supplement Mode**

**Figure 22. Battery Pack Temperature Sensing – TS Pin. Battery Temperature Increasing**



## 9 Application and Implementation

---

### NOTE

Information in the following applications sections is not part of the TI component specification, and TI does not warrant its accuracy or completeness. TI's customers are responsible for determining suitability of components for their purposes. Customers should validate and test their design implementation to confirm system functionality.

---

### 9.1 Application Information

The bq2423xH devices power the system while simultaneously and independently charging the battery. The input power source for charging the battery and running the system can be an AC adapter or a USB port. The devices feature dynamic power-path management (DPPM), which shares the source current between the system and battery charging and automatically reduces the charging current if the system load increases. When charging from a USB port, the input dynamic power management ( $V_{IN}$ -DPM) circuit reduces the input current limit if the input voltage falls below a threshold, preventing the USB port from crashing. The power-path architecture also permits the battery to supplement the system current requirements when the adapter cannot deliver the peak system currents.

The bq24232xH is configureable to be host controlled for selecting different input current limits based on the input source connected, or a fully stand alone device for applications that do not support multiple types of input sources.

### 9.2 Typical Application

$V_{IN} = V_{UVLO}$  to  $V_{OVP}$ ,  $I_{FASTCHG} = 200$  mA,  $I_{IN(MAX)} = 500$  mA, Battery Temperature Charge Range 0°C to 50°C, 6.25-hour Fast Charge Safety Timer.

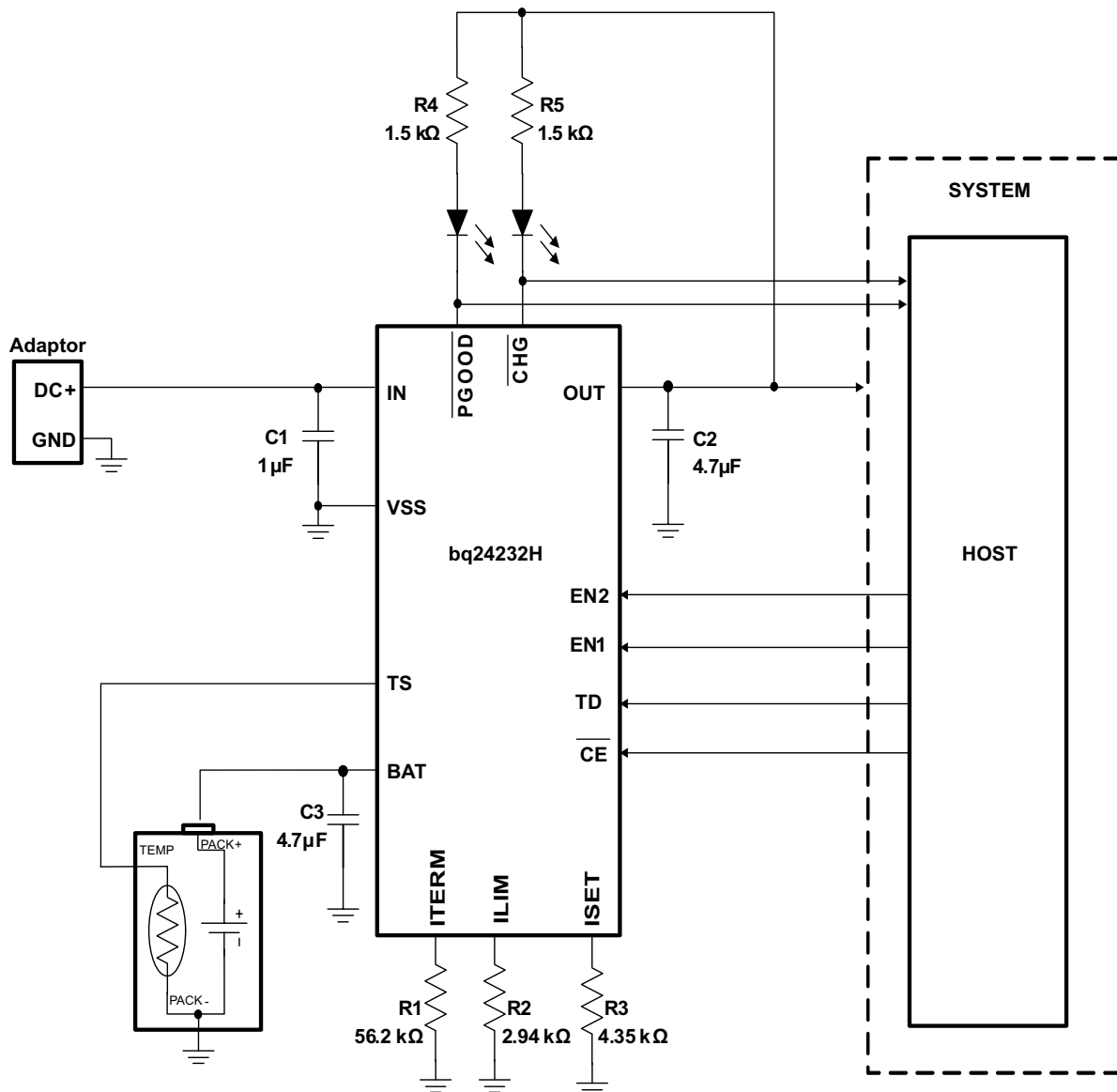
**Typical Application (continued)**

**Figure 23. Using the bq24230H in a Host-Controlled Charger Application**
**9.2.1 Design Requirements**

- Supply voltage = 5 V
- Fast-charge current of approximately 200 mA; ISET - pin 16
- Input Current Limit = 500 mA; ILIM - pin 12
- Termination Current = 25 mA - pin 15
- Safety timer duration, Fast charge = 6.25 hours; TMR – pin 14
- TS – Battery Temperature Sense = 10 kΩ NTC (103AT-2)

## Typical Application (continued)

### 9.2.2 Detailed Design Procedure

#### 9.2.2.1 Calculations

##### 9.2.2.1.1 Program the Fast-Charge Current (ISET):

$$R_{ISET} = K_{ISET} / I_{CHG}$$

$K_{ISET} = 870 \text{ A}\Omega$  from the electrical characteristics table.

$$R_{ISET} = 870 \text{ A}\Omega / 0.2 \text{ A} = 4.35 \text{ k}\Omega$$

Select the closest standard value, which for this case is 4.32 k $\Omega$ . Connect this resistor between ISET (pin 16) and  $V_{SS}$ .

##### 9.2.2.1.2 Program the Input Current Limit (ILIM)

$$R_{ILIM} = K_{ILIM} / I_{L\_MAX}$$

$K_{ILIM} = 1530 \text{ A}\Omega$  from the electrical characteristics table.

$$R_{ILIM} = 1530 \text{ A}\Omega / 0.5 \text{ A} = 3.06 \text{ k}\Omega$$

Select the closest standard value, which for this case is 3.06 k $\Omega$ . Connect this resistor between ILIM (pin 12) and  $V_{SS}$ .

##### 9.2.2.1.3 Program the Termination Current Threshold (ITERM)

$$R_{ITERM} = R_{ISET} \times I_{TERM} / K_{ITERM}$$

$K_{ITERM} = 0.03 \text{ A}$  from electrical characteristics table

$$R_{ITERM} = 4.32 \text{ k}\Omega \times 0.025 \text{ A} / 0.03 \text{ A} = 3.6 \text{ k}\Omega$$

Select the closest standard value, which for this case is 3.57 k $\Omega$ . Connect this resistor between ITERM (pin 15) and  $V_{SS}$ .

##### 9.2.2.1.4 Program 6.25-Hour Fast-Charge Safety Timer (TMR)

$$R_{TMR} = t_{MAXCHG} / (10 \times K_{TMR})$$

$K_{TMR} = 40 \text{ s/k}\Omega$  from the electrical characteristics table.

$$R_{TMR} = (6.25 \text{ hr} \times 3600 \text{ s/hr}) / (10 \times 40 \text{ s/k}\Omega) = 56.25 \text{ k}\Omega$$

Select the closest standard value, which for this case is 56.2 k $\Omega$ . Connect this resistor between TMR (pin 2) and  $V_{SS}$ .

#### 9.2.2.2 TS Function

Use a 10-k $\Omega$  NTC thermistor in the battery pack (103AT). To disable the temperature sense function, use a fixed 10-k $\Omega$  resistor between the TS (pin 1) and  $V_{SS}$ . Pay close attention to the linearity of the chosen NTC so that it provides the desired hot and cold turnoff thresholds.

#### 9.2.2.3 $\overline{CHG}$ and $\overline{PGOOD}$

LED Status: connect a 1.5-k $\Omega$  resistor in series with a LED between OUT and  $\overline{CHG}$  and OUT and  $\overline{PGOOD}$ .

Processor Monitoring Status: connect a pullup resistor (approximately 100 k $\Omega$ ) between the power rail of the processor and  $\overline{CHG}$  and  $\overline{PGOOD}$ .

#### 9.2.2.4 Selecting IN, OUT, AND BAT Pin Capacitors

In most applications, all that is needed is a high-frequency decoupling capacitor (ceramic) on the power pin, input, output, and battery pins. Using the values shown on the application diagram is recommended. After evaluation of these voltage signals with real system operational conditions, the user can determine if capacitance values can be adjusted toward the minimum recommended values (DC load application) or higher values for fast, high-amplitude, pulsed load applications.

## Typical Application (continued)

### NOTE

If designed with high input voltage sources (bad adapters or wrong adapters), the capacitor needs to be rated appropriately. Ceramic capacitors are tested to 2x their rated values so a 16-V capacitor may be adequate for a 30-V transient (verify tested rating with capacitor manufacturer).

### 9.2.2.5 Sleep Mode

After entering sleep mode for >20 ms, the internal FET connection between the IN and OUT pin is disabled and pulling the input to ground does not discharge the battery, other than the leakage on the BAT pin. If the user has a full 1000-mAhr battery and the leakage is 10  $\mu$ A, then it takes 1000 mAhr/10  $\mu$ A = 100000 hours (11.4 years) to discharge the battery. The self-discharge of the battery is typically five times higher.

## 9.2.3 Application Curves

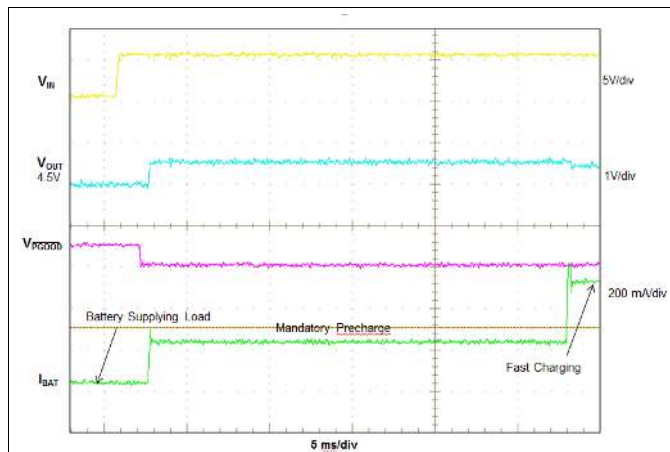

Figure 24. Adapter Plug-In With Battery Connected  
 $R_{LOAD} = 25\Omega$

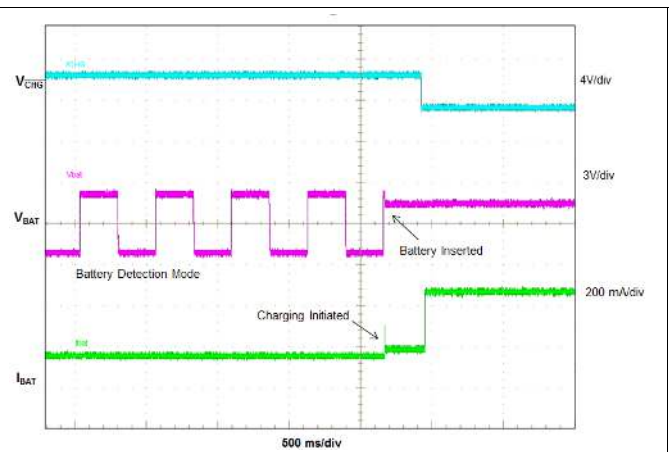

Figure 25. Battery Detection -- Insertion

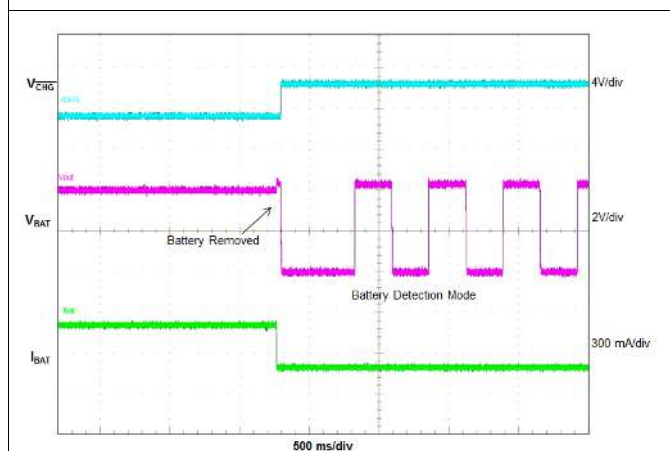

Figure 26. Battery Detection -- Removal

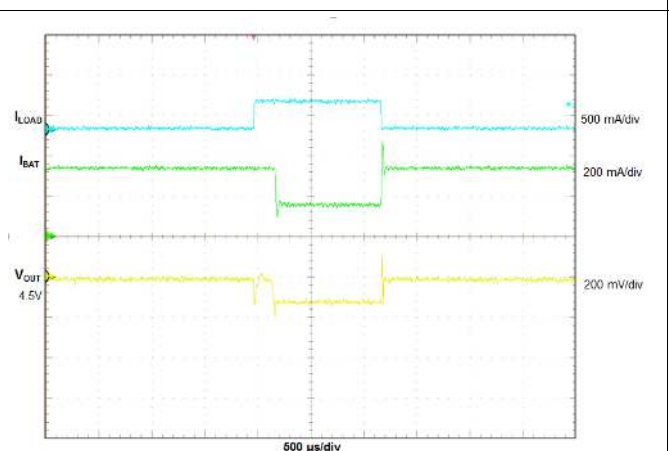
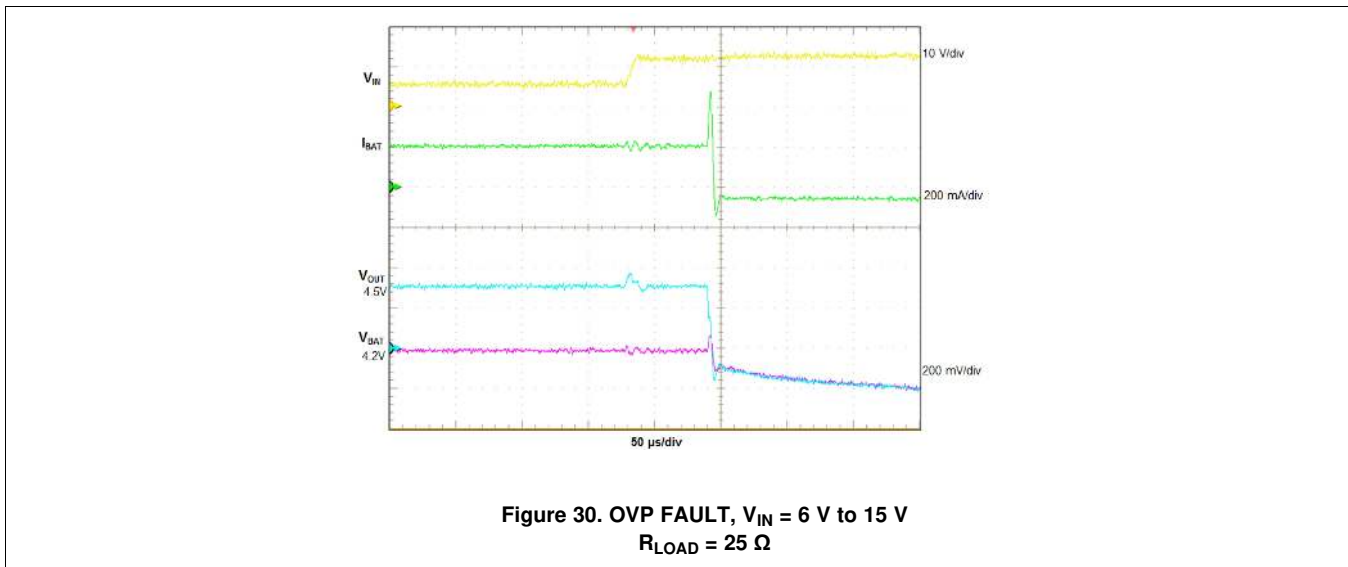
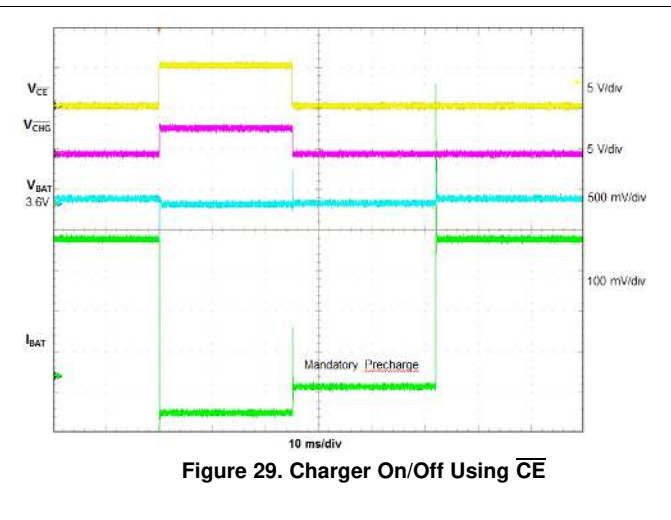
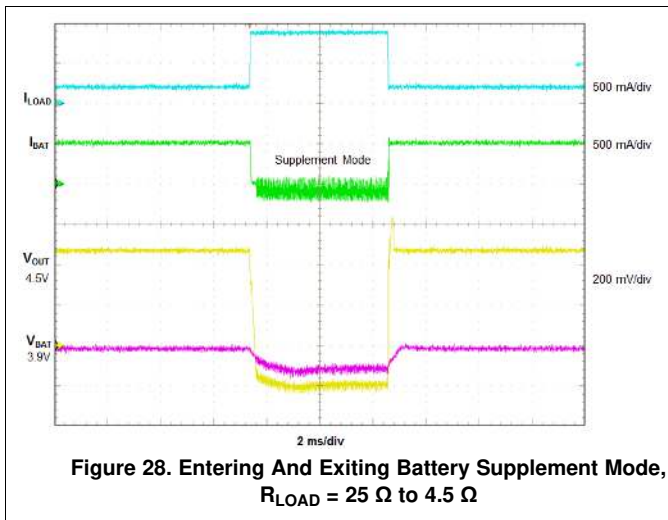

Figure 27. Entering and Exiting DPPM Mode  
 $R_{LOAD} = 25\Omega$  to  $9\Omega$

Typical Application (continued)



## 9.3 System Examples

### 9.3.1 Stand-Alone Charger

$V_{IN} = V_{UVLO}$  to  $V_{OVP}$ ,  $I_{FASTCHG} = 200$  mA,  $I_{IN(MAX)} = 500$  mA, 25-mA Termination Current, ISET mode (EN1=0, EN2=1), Battery Temperature Charge Range 0°C to 50°C, 6.25-hour Fast Charge Safety Timer.

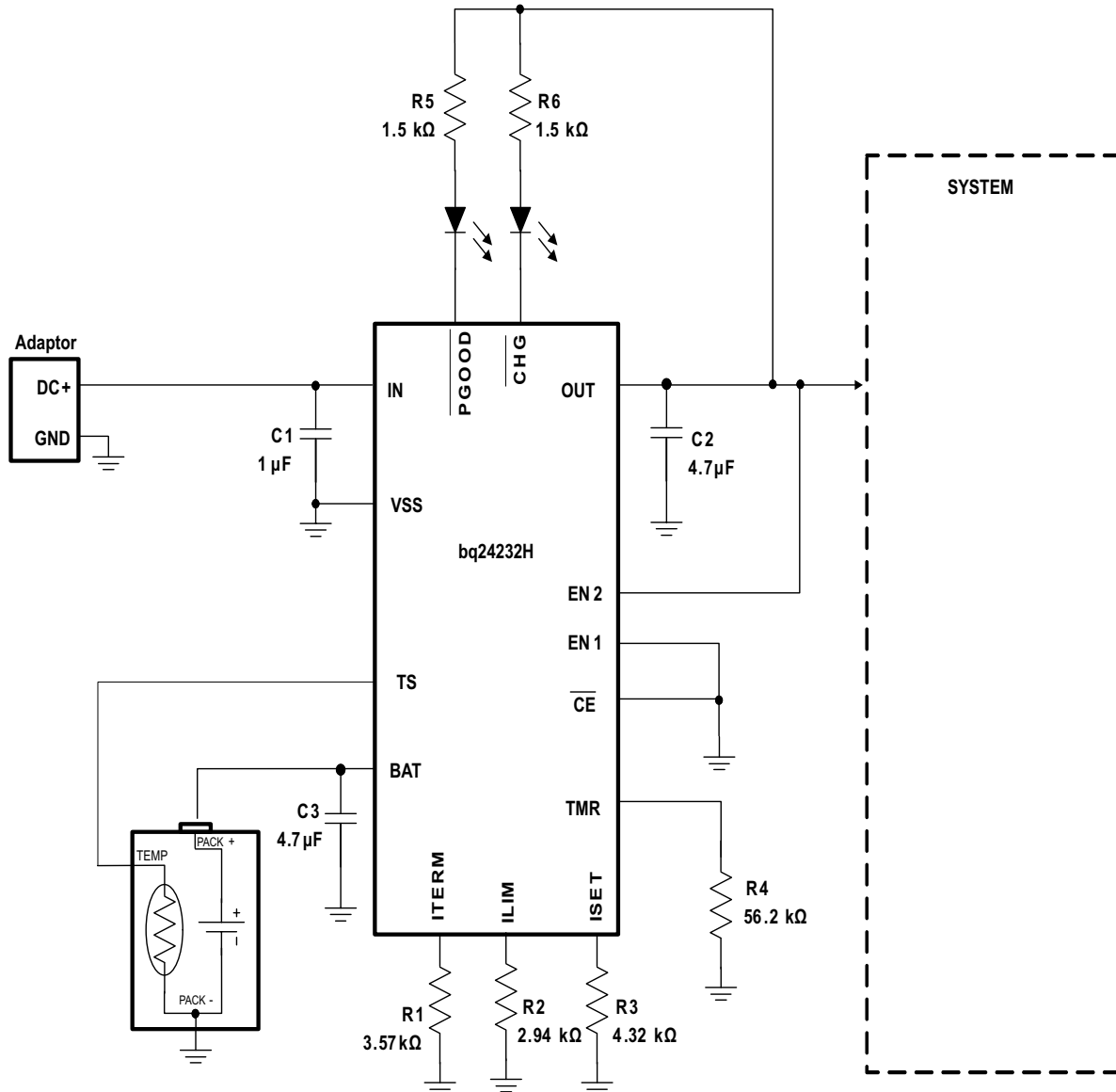

**Figure 31. Using the bq24232H in a Stand-Alone Charger Application**

The selection of components follows the Host-Controlled example above. The difference is that the EN1, EN2, and CE pins are hardwired for the required settings. See [Table 1](#) for the EN1 and EN2 settings.

## 10 Power Supply Recommendations

### 10.1 Requirements for OUT Output

To provide an output voltage on SYS, the bq2423xH require either a power supply from 4.35 V to 6.0 V input for bq24230H and from 4.35 V to 10 V for bq24232H to fully charge a battery. The supply must have at least 100 mA current rating connected to IN; or, a single-cell Li-Ion battery with voltage > VBATUVLO connected to BAT. The source current rating needs to be at least 1.5 A in order to provide maximum output current to SYS.

### 10.2 USB Sources and Standard AC Adapters

In order for charging to occur the source voltage measured at the IN terminals of the IC, factoring in cable/trace losses from the source, must be greater than the VINDPM threshold (in USB mode), but less than the maximum values shown above. The current rating of the source must be higher than the load requirements for OUT in the application. For charging at a desired charge current of ICHRG, IIN > (ISYS+ ICHRG). The charger limits IIN to the current limit setting of EN1/EN2.

### 10.3 Half-Wave Adapters

Some low-cost adapters implement a half rectifier topology, which causes the adapter output voltage to fall below the battery voltage during part of the cycle. To enable operation with low-cost adapters under those conditions, the bq2423xH family keeps the charger on for at least 20 ms (typical) after the input power puts the part in sleep mode. This feature enables use of external low-cost adapters using 50-Hz networks.

## 11 Layout

### 11.1 Layout Guidelines

- To obtain optimal performance, the decoupling capacitor from IN to GND (thermal pad) and the output filter capacitors from OUT to GND (thermal pad) must be placed as close as possible to the bq2423xH, with short trace runs to both IN, OUT, and GND (thermal pad).
- All low-current GND connections must be kept separate from the high-current charge or discharge paths from the battery. Use a single-point ground technique incorporating both the small signal ground path and the power ground path.
- The high current charge paths into the IN pin and from the OUT pin must be sized appropriately for the maximum charge current in order to avoid voltage drops in these traces.
- The bq2423xH family is packaged in a thermally enhanced MLP package. The package includes a thermal pad to provide an effective thermal contact between the IC and the printed-circuit board (PCB); this thermal pad is also the main ground connection for the device. Connect the thermal pad to the PCB ground connection. Full PCB design guidelines for this package are provided in the application report entitled: QFN/SON PCB Attachment ([SLUA271](#)).

## 11.2 Layout Example

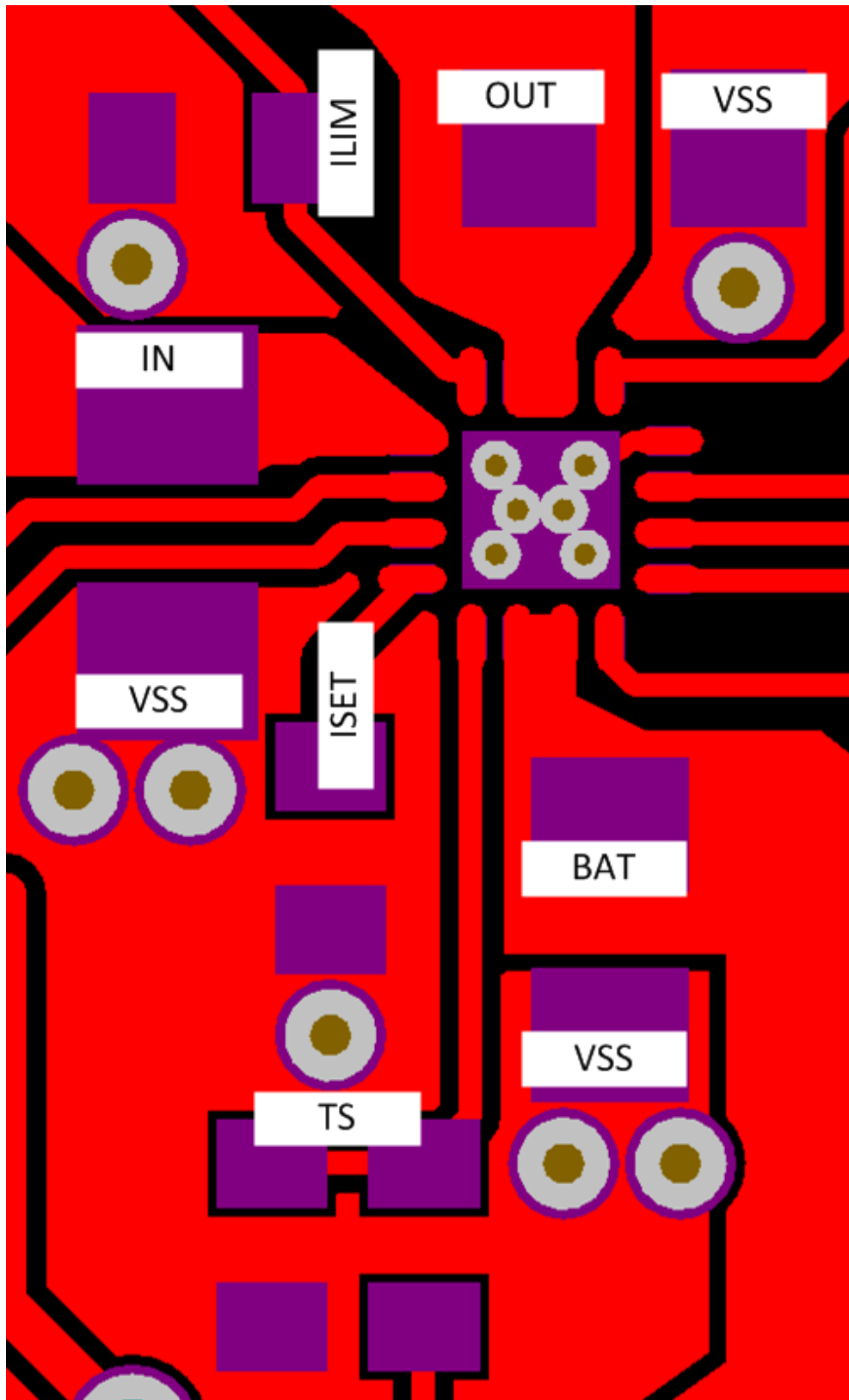

**Figure 32. Layout Example**



### 11.3 Thermal Package

The bq2423xH is packaged in a thermally enhanced MLP package. The package includes a thermal pad to provide an effective thermal contact between the IC and the printed-circuit board (PCB). The power pad must be directly connected to the V<sub>SS</sub> pin. Full PCB design guidelines for this package are provided in the application report entitled: QFN/SON PCB Attachment ([SLUA271](#)). The most common measure of package thermal performance is thermal impedance ( $\theta_{JA}$ ) measured (or modeled) from the chip junction to the air surrounding the package surface (ambient). The mathematical expression for  $\theta_{JA}$  is:

$$\theta_{JA} = (T_J - T) / P$$

Where:

$T_J$  = chip junction temperature

$T$  = ambient temperature

$P$  = device power dissipation

Factors that can greatly influence the measurement and calculation of  $\theta_{JA}$  include:

- Whether the device is board mounted
- Trace size, composition, thickness, and geometry
- Orientation of the device (horizontal or vertical)
- Volume of the ambient air surrounding the device under test and airflow
- Whether other surfaces are in close proximity to the device being tested

Due to the charge profile of Li-ion batteries, the maximum power dissipation is typically seen at the beginning of the charge cycle when the battery voltage is at its lowest. Typically, after fast charge begins, the pack voltage increases to approximately 3.4 V within the first 2 minutes. The thermal time constant of the assembly typically takes a few minutes to heat up so when doing maximum power dissipation calculations, 3.4 V is a good minimum voltage to use. This is easy to verify, with the system and a fully discharged battery, by plotting temperature on the bottom of the PCB under the IC (pad must have multiple vias), the charge current and the battery voltage as a function of time. The fast-charge current starts to taper off if the part goes into thermal regulation.

The device power dissipation,  $P$ , is a function of the charge rate and the voltage drop across the internal PowerFET. It can be calculated from the following equation when a battery pack is being charged :

$$P = [V_{(IN)} - V_{(OUT)}] \times I_{(OUT)} + [V_{(OUT)} - V_{(BAT)}] \times I_{(BAT)}$$

The thermal loop feature reduces the charge current to limit excessive IC junction temperature. It is recommended that the design not run in thermal regulation for typical operating conditions (nominal input voltage and nominal ambient temperatures) and use the feature for nontypical situations such as hot environments or higher than normal input source voltage. With that said, the IC still performs as described, if the thermal loop is always active.

## 12 Device and Documentation Support

### 12.1 Documentation Support

#### 12.1.1 Related Documentation

- QFN/SON PCB Attachment, [SLUA271](#)

### 12.2 Related Links

The table below lists quick access links. Categories include technical documents, support and community resources, tools and software, and quick access to sample or buy.

**Table 4. Related Links**

PARTS	PRODUCT FOLDER	SAMPLE & BUY	TECHNICAL DOCUMENTS	TOOLS & SOFTWARE	SUPPORT & COMMUNITY
bq24230H	<a href="#">Click here</a>	<a href="#">Click here</a>	<a href="#">Click here</a>	<a href="#">Click here</a>	<a href="#">Click here</a>
bq24232H	<a href="#">Click here</a>	<a href="#">Click here</a>	<a href="#">Click here</a>	<a href="#">Click here</a>	<a href="#">Click here</a>

### 12.3 Trademarks

Bluetooth is a registered trademark of Bluetooth SIG, Inc. All other trademarks are the property of their respective owners.

### 12.4 Electrostatic Discharge Caution



These devices have limited built-in ESD protection. The leads should be shorted together or the device placed in conductive foam during storage or handling to prevent electrostatic damage to the MOS gates.

### 12.5 Glossary

[SLYZ022](#) — *TI Glossary*.

This glossary lists and explains terms, acronyms, and definitions.

## 13 Mechanical, Packaging, and Orderable Information

The following pages include mechanical, packaging, and orderable information. This information is the most current data available for the designated devices. This data is subject to change without notice and revision of this document. For browser-based versions of this data sheet, refer to the left-hand navigation.

**PACKAGING INFORMATION**

Orderable Device	Status (1)	Package Type	Package Drawing	Pins	Package Qty	Eco Plan (2)	Lead finish/ Ball material (6)	MSL Peak Temp (3)	Op Temp (°C)	Device Marking (4/5)	Samples
BQ24232HRGTR	ACTIVE	VQFN	RGT	16	3000	RoHS & Green	NIPDAU	Level-2-260C-1 YEAR	-40 to 85	24232H	<a href="#">Samples</a>
BQ24232HRGTT	ACTIVE	VQFN	RGT	16	250	RoHS & Green	NIPDAU	Level-2-260C-1 YEAR	-40 to 85	24232H	<a href="#">Samples</a>

(1) The marketing status values are defined as follows:

**ACTIVE:** Product device recommended for new designs.

**LIFEBUY:** TI has announced that the device will be discontinued, and a lifetime-buy period is in effect.

**NRND:** Not recommended for new designs. Device is in production to support existing customers, but TI does not recommend using this part in a new design.

**PREVIEW:** Device has been announced but is not in production. Samples may or may not be available.

**OBSOLETE:** TI has discontinued the production of the device.

(2) **RoHS:** TI defines "RoHS" to mean semiconductor products that are compliant with the current EU RoHS requirements for all 10 RoHS substances, including the requirement that RoHS substance do not exceed 0.1% by weight in homogeneous materials. Where designed to be soldered at high temperatures, "RoHS" products are suitable for use in specified lead-free processes. TI may reference these types of products as "Pb-Free".

**RoHS Exempt:** TI defines "RoHS Exempt" to mean products that contain lead but are compliant with EU RoHS pursuant to a specific EU RoHS exemption.

**Green:** TI defines "Green" to mean the content of Chlorine (Cl) and Bromine (Br) based flame retardants meet JS709B low halogen requirements of <=1000ppm threshold. Antimony trioxide based flame retardants must also meet the <=1000ppm threshold requirement.

(3) MSL, Peak Temp. - The Moisture Sensitivity Level rating according to the JEDEC industry standard classifications, and peak solder temperature.

(4) There may be additional marking, which relates to the logo, the lot trace code information, or the environmental category on the device.

(5) Multiple Device Markings will be inside parentheses. Only one Device Marking contained in parentheses and separated by a "~" will appear on a device. If a line is indented then it is a continuation of the previous line and the two combined represent the entire Device Marking for that device.

(6) Lead finish/Ball material - Orderable Devices may have multiple material finish options. Finish options are separated by a vertical ruled line. Lead finish/Ball material values may wrap to two lines if the finish value exceeds the maximum column width.

**Important Information and Disclaimer:**The information provided on this page represents TI's knowledge and belief as of the date that it is provided. TI bases its knowledge and belief on information provided by third parties, and makes no representation or warranty as to the accuracy of such information. Efforts are underway to better integrate information from third parties. TI has taken and continues to take reasonable steps to provide representative and accurate information but may not have conducted destructive testing or chemical analysis on incoming materials and chemicals. TI and TI suppliers consider certain information to be proprietary, and thus CAS numbers and other limited information may not be available for release.

In no event shall TI's liability arising out of such information exceed the total purchase price of the TI part(s) at issue in this document sold by TI to Customer on an annual basis.



**TAPE AND REEL INFORMATION**

**QUADRANT ASSIGNMENTS FOR PIN 1 ORIENTATION IN TAPE**

\*All dimensions are nominal

Device	Package Type	Package Drawing	Pins	SPQ	Reel Diameter (mm)	Reel Width W1 (mm)	A0 (mm)	B0 (mm)	K0 (mm)	P1 (mm)	W (mm)	Pin1 Quadrant
BQ24232HRGTR	VQFN	RGT	16	3000	330.0	12.4	3.3	3.3	1.1	8.0	12.0	Q2
BQ24232HRGTR	VQFN	RGT	16	3000	330.0	12.4	3.3	3.3	1.1	8.0	12.0	Q2
BQ24232HRGTT	VQFN	RGT	16	250	180.0	12.4	3.3	3.3	1.1	8.0	12.0	Q2

## TAPE AND REEL BOX DIMENSIONS



\*All dimensions are nominal

Device	Package Type	Package Drawing	Pins	SPQ	Length (mm)	Width (mm)	Height (mm)
BQ24232HRGTR	VQFN	RGT	16	3000	346.0	346.0	33.0
BQ24232HRGTR	VQFN	RGT	16	3000	367.0	367.0	35.0
BQ24232HRGTT	VQFN	RGT	16	250	210.0	185.0	35.0

**RGT 16**

**GENERIC PACKAGE VIEW**

**VQFN - 1 mm max height**

PLASTIC QUAD FLATPACK - NO LEAD

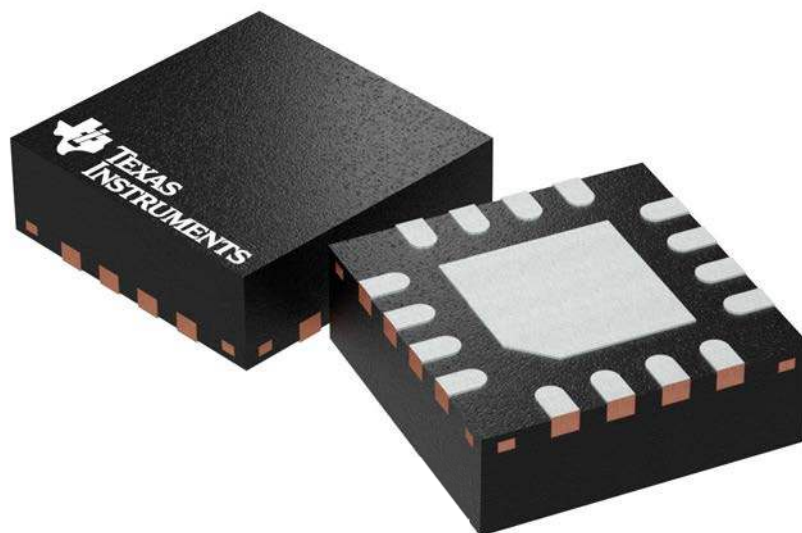

Images above are just a representation of the package family, actual package may vary.  
Refer to the product data sheet for package details.

4203495/1

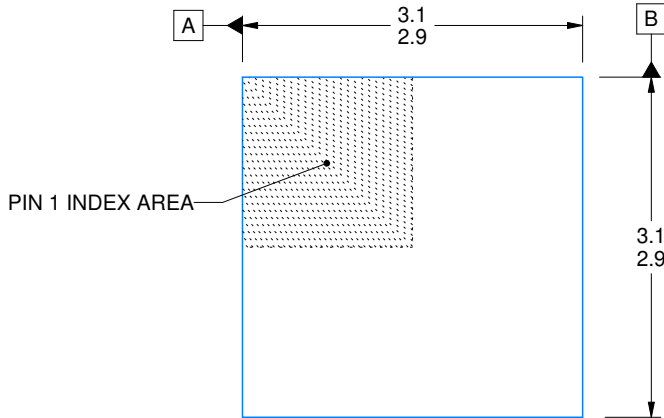
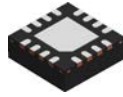

SIDE WALL METAL THICKNESS DIM A	
OPTION 1	OPTION 2
0.1	0.2

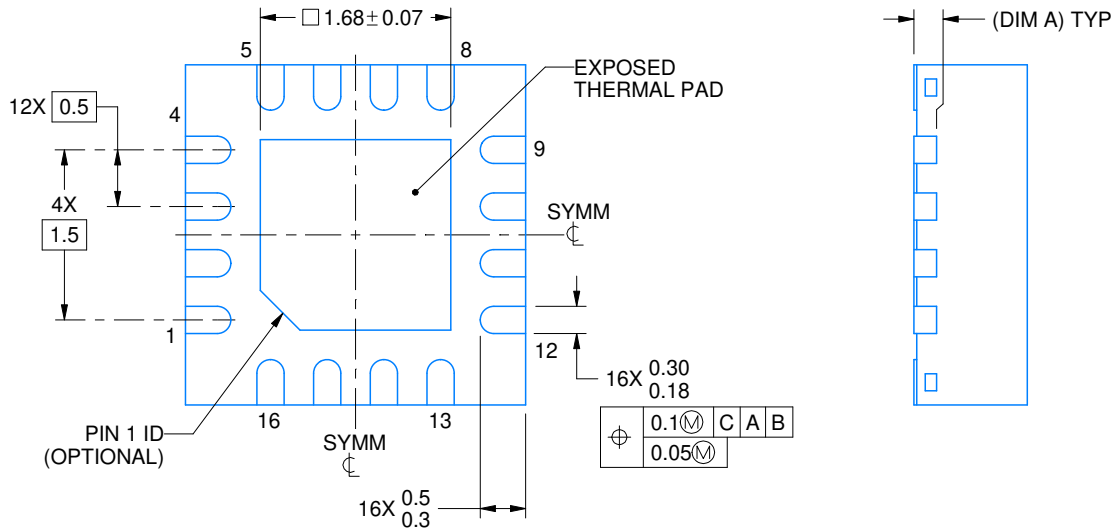
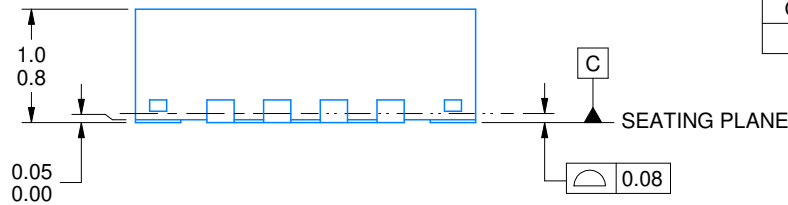

4222419/D 04/2022

NOTES:

1. All linear dimensions are in millimeters. Any dimensions in parenthesis are for reference only. Dimensioning and tolerancing per ASME Y14.5M.
2. This drawing is subject to change without notice.
3. The package thermal pad must be soldered to the printed circuit board for thermal and mechanical performance.





# EXAMPLE STENCIL DESIGN

RGT0016C

VQFN - 1 mm max height

PLASTIC QUAD FLATPACK - NO LEAD

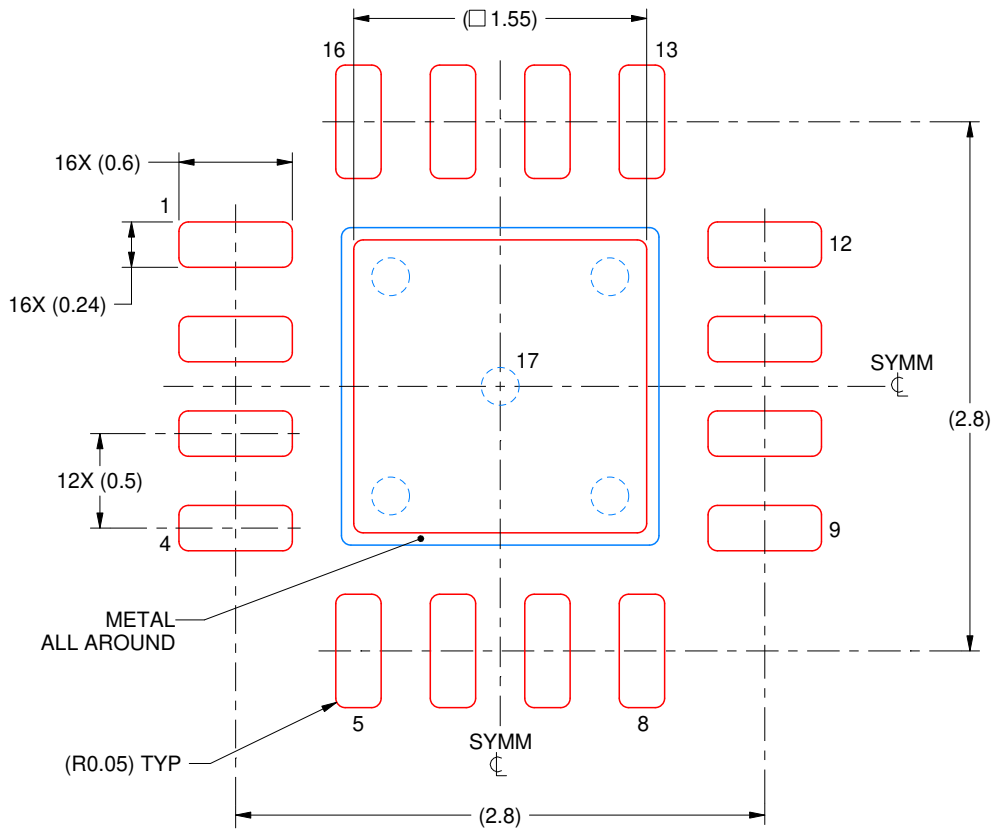

**SOLDER PASTE EXAMPLE**  
BASED ON 0.125 mm THICK STENCIL

EXPOSED PAD 17:  
85% PRINTED SOLDER COVERAGE BY AREA UNDER PACKAGE  
SCALE:25X

4222419/D 04/2022

NOTES: (continued)

6. Laser cutting apertures with trapezoidal walls and rounded corners may offer better paste release. IPC-7525 may have alternate design recommendations.

## IMPORTANT NOTICE AND DISCLAIMER

TI PROVIDES TECHNICAL AND RELIABILITY DATA (INCLUDING DATA SHEETS), DESIGN RESOURCES (INCLUDING REFERENCE DESIGNS), APPLICATION OR OTHER DESIGN ADVICE, WEB TOOLS, SAFETY INFORMATION, AND OTHER RESOURCES "AS IS" AND WITH ALL FAULTS, AND DISCLAIMS ALL WARRANTIES, EXPRESS AND IMPLIED, INCLUDING WITHOUT LIMITATION ANY IMPLIED WARRANTIES OF MERCHANTABILITY, FITNESS FOR A PARTICULAR PURPOSE OR NON-INFRINGEMENT OF THIRD PARTY INTELLECTUAL PROPERTY RIGHTS.

These resources are intended for skilled developers designing with TI products. You are solely responsible for (1) selecting the appropriate TI products for your application, (2) designing, validating and testing your application, and (3) ensuring your application meets applicable standards, and any other safety, security, regulatory or other requirements.

These resources are subject to change without notice. TI grants you permission to use these resources only for development of an application that uses the TI products described in the resource. Other reproduction and display of these resources is prohibited. No license is granted to any other TI intellectual property right or to any third party intellectual property right. TI disclaims responsibility for, and you will fully indemnify TI and its representatives against, any claims, damages, costs, losses, and liabilities arising out of your use of these resources.

TI's products are provided subject to [TI's Terms of Sale](#) or other applicable terms available either on [ti.com](https://www.ti.com) or provided in conjunction with such TI products. TI's provision of these resources does not expand or otherwise alter TI's applicable warranties or warranty disclaimers for TI products.

TI objects to and rejects any additional or different terms you may have proposed.

Mailing Address: Texas Instruments, Post Office Box 655303, Dallas, Texas 75265  
Copyright © 2023, Texas Instruments Incorporated