

1

2

3

4

5

6

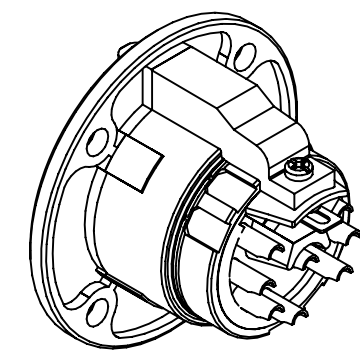
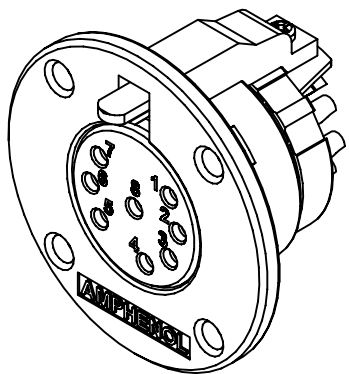

ISO VIEW

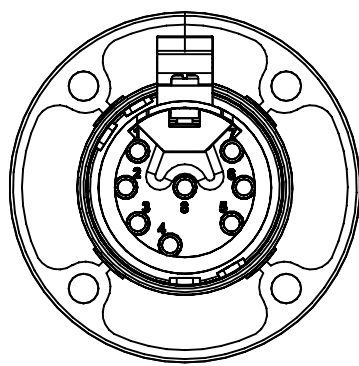

BACK VIEW

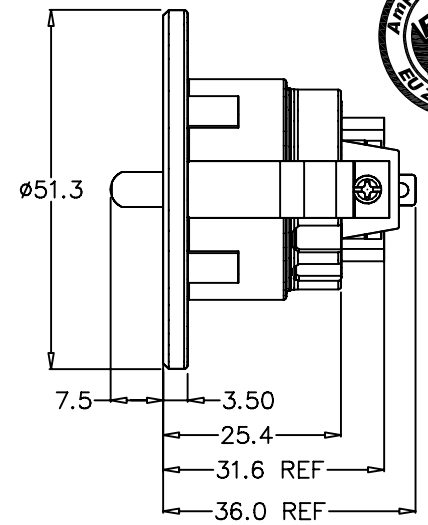
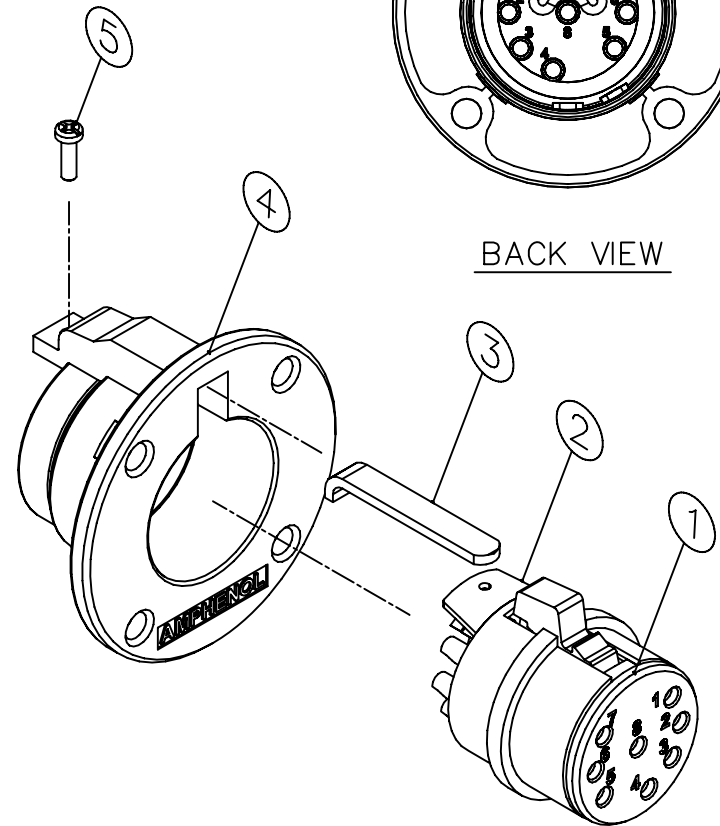

TOP VIEW

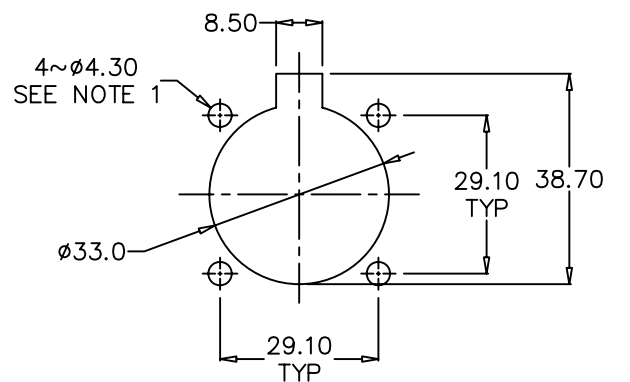

PANEL CUT OUT



EP-* - 13P TYPE	EP/AP INSERT P/N
EP - 3 - 13P	156-4401-003
EP - 4 - 13P	156-4401-004
EP - 5 - 13P	156-4401-005
EP - 6 - 13P	156-4401-006
EP - 8 - 13P	156-4401-008

NOTE: 1. THE DIAMETER OF THE 4 MOUNTING HOLES ON THE PANEL CUT OUT DEPENDS ON THE SIZE OF THE SCREW TO BE USED
 2. FOR EXAMPLE: FOR AN EP-8-13P USE ASSY No. 128201-0008

ITEM	PART No.	DWG No.	DESCRIPTION	QTY
5	990-4400-000	990-4400-000	2-32 PAN HEAD SCREW, LONG	1
4	248-4100-0**	248-4100-0**	DIE CAST SHELL	1
3	208-4001-000	208-4001-000	EP/AP LATCH LEVER	1
2	011-4400-000	011-4400-000	EP/AP BARREL	1
1	SEE TABLE	SEE TABLE	EP SOCKET INSULATOR ASSY	1

UNLESS OTHERWISE SPECIFIED TOLERANCE TO BE

LINEAR	ANGULAR
X ± 1.00	X' ± 1°
X.X ± 0.50	X'X' ± 30'
X.XX ± 0.20	X'X'X' ± 15'

BREAK ALL SHARP EDGES AND REMOVE ALL BURRS
 DO NOT SCALE
 FINISH: REFER TO COMPONENT
 CAD FILE: 00804104 DRN: S.M.D DATE: 07-02-90
 MATL: REFER TO COMPONENT CKD: M.H DATE: 19-11-08
 APP'D: P.M DATE: 19-11-08
 DIMENSIONS IN MILLIMETRES THIRD ANGLE PROJECTION SCALE: 2:1 UOS PART No: SEE TABLE

4	OMIT PART NUMBER EP - 2 - 13P PRODUCT OBSOLETE	M.N.H	19-11-08	8784
3	UPDATE TO AMPHENOL TITLE BLOCK & LOGO REDRAW, ADD BOM & PANEL CUT OUT DETAILS	M.N.H.	12-04-01	7782
1	FIRST ISSUE	S.M.D	07-02-90	----
REV.	CHANGE DETAILS	BY	DATE	CHG/No

TITLE: EP-* - 13P CUSTOMER DRAWING

Amphenol
 Amphenol Australia Pty.Ltd, 2 Fireweys Blvd, Keysborough, Vic3173
 DRAWING NO. 128201-000* SHEET 1 OF 1

1

2

3

4

5

6