

REVISION RECORD				
REV	ECO	DESCRIPTION	DRFT	CHKD
△		ADD P/N.	GSJ 8/25/05	
△		MODIFY DRAWING	SKYCHEN 09/04/08	

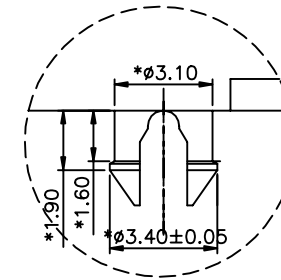

△ DETAIL "B"
SCALE 2:1

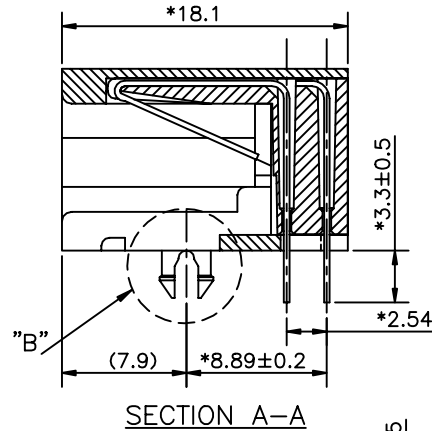
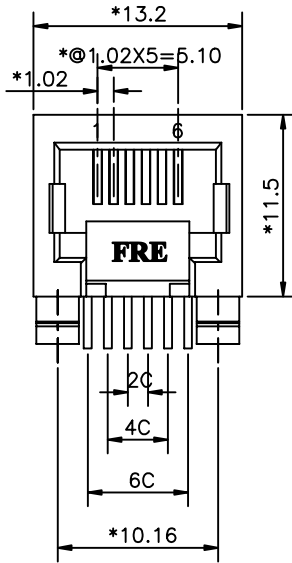
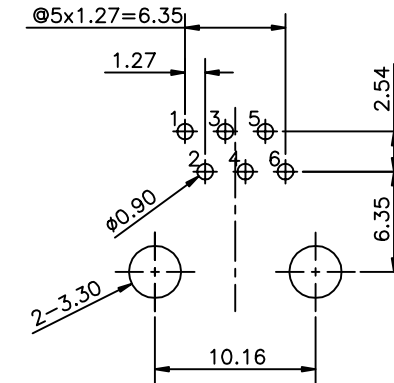
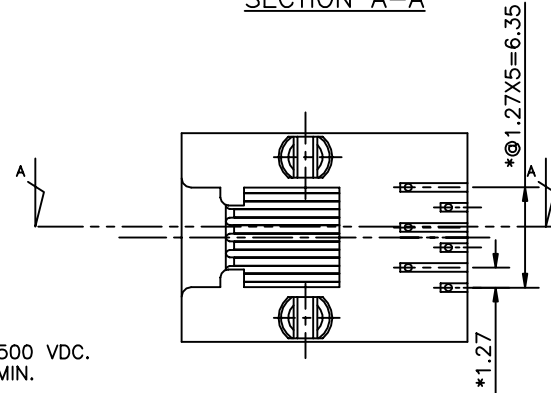

PC BOARD LAYOUT COMPONENT SIDE SHOWN

NOTES:

ELECTRICAL:

- VOLTAGE RATING : 150 VAC RMS.
- CURRENT RATING : 1.5 AMP.
- CONTACT RESISTANCE : 30 MILLIOHMS MAX.
- INSULATION RESISTANCE: 1000 MEGOHMS MIN @ 500 VDC.
- DIELECTRIC STRENGTH : 1000 VAC RMS 60Hz, 1MIN.

MECHANICAL:

- HOUSING MATERIAL : NYLON+GF30% UL94V-0./COLOR:BLACK OR GREEN OR GRAY.
- CONTACT MATERIAL : PHOSPHOR BRONZE ϕ 0.46mm.
- PLATING : GOLD PLATING OVER NICKEL.
- OPERATING LIFE : 750 CYCLES MIN.
- PCB RETENTION PRE-SOLDER : 1 LB MIN.
- PCB RETENTION POST-SOLDER: 10 LBS MIN.

ENVIRONMENTAL:

- STORAGE : -40°C TO +85°C.
- OPERATION: -40°C TO +85°C.
- WAVE SOLDERING TEMPERATURE: 255°C TO 265°C 5~10 SECONDS.
- RoHS COMPLIANT.

MATES WITH MODULAR PLUG CONFORMING TO
FCC PART 68, SUBPART F.

△ RoHS PART NUMBER: E536X-S00XXX-L

NO OF CONTACT:

- 2- 2C
- 4- 4C
- 6- 6C

- 1- 3u" 2- 6u"
- 3- 15u" 4- 30u"
- 5- 50u" 6- Pd 20u"

- A1-GREEN (NYLON+GF30%) W/O KEY
- 31-GRAY (NYLON+GF30%) W/O KEY
- 51-BLACK (NYLON+GF30%) W/O KEY

MM (INCH)		DFTO SAMMY	DATE 06/07/05
TOLERANCES EXCEPT AS NOTED		CHKD	DATE
		MFO	DATE
		APPVL	DATE
MM	±	MATERIAL :	
.0 ± 0.2	±	QT'Y :	
.00 ± 0.15	±	FINISH :	
.000 ± 0.075	±	SCALE : 3:1	
ANGLES ± 0.5		THIRD ANGLE PROJECTION	

	RoHS Compliant
FULL RISE ELECTRONIC CO., LTD	
TITLE	
11.5 SIDE ENTRY 6P	
DRAWING NO. GE533A31-LA	SIZE A3
/PART NO. SEE NOTE	REV 2
DO NOT SCALE DRAWING	SHEET 1 OF 1