

DATA SHEET

SKY13330-397LF: 0.1 to 6.0 GHz SPDT Switch

Applications

- WCDMA band and mode switching
- Antenna switch for multimode systems

Features

- Broadband frequency range: 0.1 GHz to 6.0 GHz
- Low insertion loss:
 - 0.35 dB @ 2.2 GHz
 - 0.60 dB @ 6 GHz
- High IP1dB: +39 dBm
- No external DC blocking capacitors required
- Positive low control voltage range: 1.65 V to 2.70 V
- DC supply voltage: 2.3 V to 4.8 V
- Small QFN (12-pin, 2 x 2 mm) package (MSL1, 260 °C per JEDEC J-STD-020)



Skyworks Green™ products are compliant with all applicable legislation and are halogen-free. For additional information, refer to *Skyworks Definition of Green™*, document number SQ04-0074.

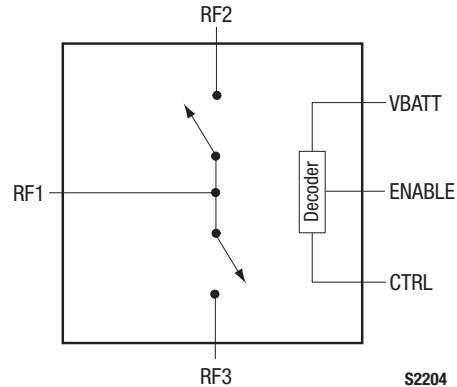

Figure 1. SKY13330-397LF Block Diagram

Description

The SKY13330-397LF is a CMOS, silicon-on-insulator (SOI) single-pole, double-throw (SPDT) switch. The high linearity and low insertion loss of the SKY13330-397LF make it an ideal choice for WCDMA handset and data card applications.

The switch is a “reflective short” on the isolated port.

The SKY13330-397LF SP2T switch is provided in a compact Quad Flat No-Lead (QFN) 2 x 2 mm package. A functional block diagram is shown in Figure 1. The pin configuration and package are shown in Figure 2. Signal pin assignments and functional pin descriptions are provided in Table 1.

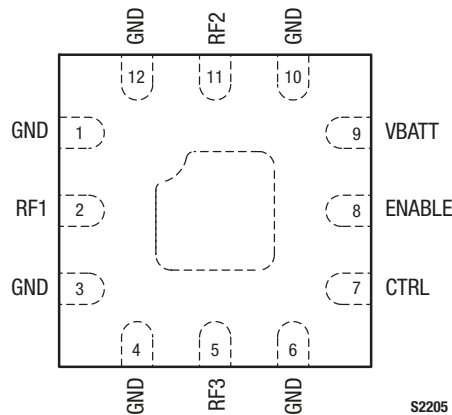

Figure 2. SKY13330-397LF Pinout (Top View)

Table 1. SKY13330-397LF Signal Descriptions¹

Pin	Name	Description	Pin	Name	Description
1	GND	Ground	7	CTRL	DC control pin. See Table 4.
2	RF1	RF port 1	8	ENABLE	Enable pin. See Table 4.
3	GND	Ground	9	VBATT	DC power supply
4	GND	Ground	10	GND	Ground
5	RF3	RF port 3	11	RF2	RF port 2
6	GND	Ground	12	GND	Ground

¹ Exposed pad must be properly grounded using a low impedance path.

Functional Description

The SKY13330-397LF is designed for medium to high power WCDMA handset and data card switching applications. The device can also be used in a variety of other applications that require high performance RF switching such as WLANs (a/b/g/n).

An internal negative voltage generator and decoder eliminate the need for external DC blocking capacitors on the RF ports unless VDC is externally applied.

Switching is controlled by one voltage input (CTRL). Depending on the logic voltage level applied to the control pin, the RF1 pin is connected to one of two switched RF outputs (RF2 or RF3) using a low insertion loss path, while the path between the RF1 pin and the other RF output pin is in a high isolation state.

An internal decoder is used to provide the correct logic to the switch.

Shutdown mode is enabled by connecting the ENABLE pin to logic low. Shutdown mode reduces the overall current consumption of the device to 7 μ A, typical.

Electrical and Mechanical Specifications

The absolute maximum ratings of the SKY13330-397LF are provided in Table 2. Electrical specifications are provided in Table 3.

The state of the SKY13330-397LF is determined by the logic provided in Table 4.

Typical performance characteristics of the SKY13330-397LF are illustrated in Figures 3 through 5.

Table 2. SKY13330-397LF Absolute Maximum Ratings¹

Parameter	Symbol	Minimum	Maximum	Units
Supply voltage	BATT		5.0	V
Input power	P _{IN}		+40	dBm
Storage temperature	T _{STG}	-40	+125	°C
Operating temperature	T _{OP}	-40	+85	°C

¹ Exposure to maximum rating conditions for extended periods may reduce device reliability. There is no damage to device with only one parameter set at the limit and all other parameters set at or below their nominal value. Exceeding any of the limits listed here may result in permanent damage to the device.

ESD HANDLING: Although this device is designed to be as robust as possible, electrostatic discharge (ESD) can damage this device. This device must be protected at all times from ESD when handling or transporting. Static charges may easily produce potentials of several kilovolts on the human body or equipment, which can discharge without detection. Industry-standard ESD handling precautions should be used at all times.

Table 3. SKY13330-397LF Electrical Specifications¹ (1 of 2)

(V_{BATT} = 2.3 V to 4.8 V, CTRL = 0/1.65 V to 2.70 V, T_{OP} = +25 °C, P_{IN} = 0 dBm, Characteristic Impedance [Z₀] = 50 Ω, Unless Otherwise Noted)

Parameter	Symbol	Test Condition	Min	Typ	Max	Units
RF Specifications						
Insertion loss	IL	RF1 to RF2/RF3: 0.1 to 1.0 GHz		0.30	0.35	dB
		1.0 to 2.2 GHz		0.35	0.50	dB
		2.2 to 2.5 GHz		0.35	0.50	dB
		2.5 to 5.0 GHz		0.45	0.65	dB
		5.0 to 6.0 GHz		0.60	0.80	dB
Isolation	Iso	RF1 to RF2/RF3: 0.1 to 1.0 GHz	40	42		dB
		1.0 to 2.2 GHz	30	34		dB
		2.2 to 2.5 GHz	30	33		dB
		2.5 to 5.0 GHz	22	24		dB
		5.0 to 6.0 GHz	18	21		dB
Return loss	IS111	RF1 to RF2/RF3, 0.1 to 6.0 GHz		20		dB
0.1 dB input compression point	IPO.1dB	RF1 to RF2/RF3, 0.8 to 2.5 GHz		+38.5		dBm
Third order intermodulation distortion	IMD3	f _{FND} = 1950 MHz @ +20 dBm, f _{BLK} = 1760 MHz @ -15 dBm		-110	-105	dBm
Switching speed		50% V _{CTL} to 10/90% RF "on" time		1.70		μs
		50% V _{CTL} to 90/10% RF "off" time		1.24		μs
		10/90% RF rise time		0.50		μs
		90/10% RF fall time		1.00		μs
Startup time ²		Shutdown state to any RF switch state		2		μs

Table 3. SKY13330-397LF Electrical Specifications¹ (2 of 2)

(**V_{BATT} = 2.3 V to 4.8 V, CTRL = 0/1.65 V to 2.70 V, T_{OP} = +25 °C, P_{IN} = 0 dBm, Characteristic Impedance [Z₀] = 50 Ω, Unless Otherwise Noted**)

Parameter	Symbol	Test Condition	Min	Typ	Max	Units
DC Specifications						
Control voltage: high	V _{CTL_HIGH}		1.65		2.7	V
low	V _{CTL_LOW}		0		0.4	V
Supply voltage	V _{BATT}		2.3		4.8	V
Supply current	I _{BATT}	V _{BATT} = 2.3 to 4.8 V		37		μA
Control current	I _{CTRL}	CTRL = 1.8 V		1		μA
Shutdown mode supply current	I _{OFF}	ENABLE = 0 V, V _{BATT} = 2.3 V to 4.8 V		7		μA

¹ Performance is guaranteed only under the conditions listed in this table.

² Startup time refers to the amount of time it takes for the switch to be fully operational when coming out of shutdown mode (EN = 0).

Table 4. SKY13330-397LF Truth Table¹

CTRL	ENABLE	Mode
1	1	RF1 to RF2
0	1	RF1 to RF3
X	0	Shutdown

¹ 1 = 1.65 to 2.70 V

0 = -0 to 0.4 V (control voltage must be ≤V_{DD} at all times)

X = don't care

Any state other than described in this table places the switch into an undefined state. An undefined state will not damage the device.

Typical Performance Characteristics

($V_{BATT} = 2.3\text{ V to }4.8\text{ V}$, $CTRL = 0/1.65\text{ V to }2.70\text{ V}$, $T_{OP} = +25\text{ }^\circ\text{C}$, $P_{IN} = 0\text{ dBm}$, Characteristic Impedance [Z_0] = $50\ \Omega$, Unless Otherwise Noted)

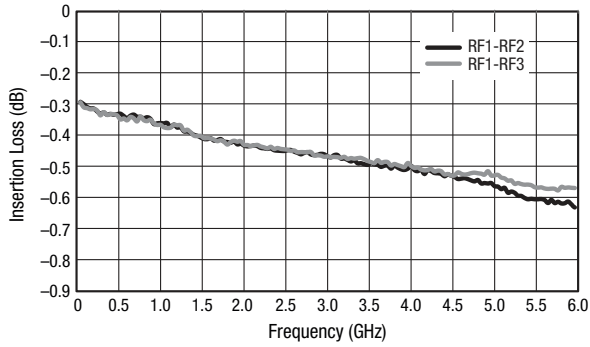

Figure 3. Insertion Loss vs Frequency

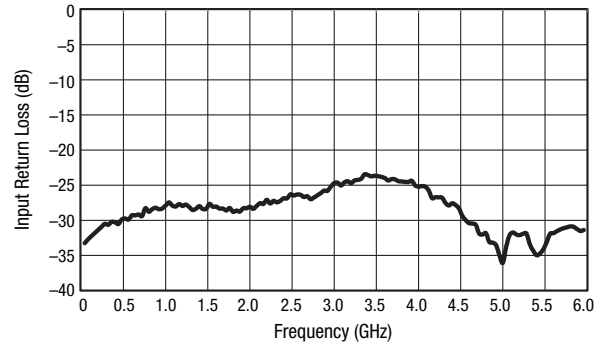

Figure 4. Input Return Loss vs Frequency

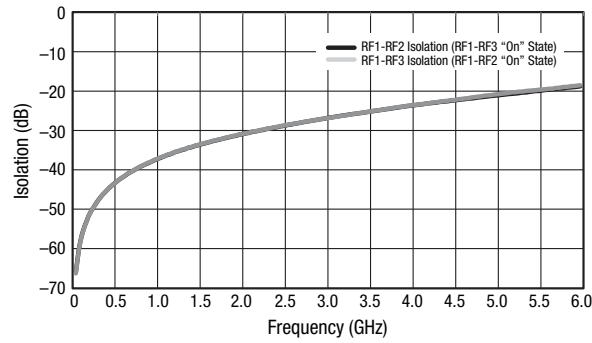
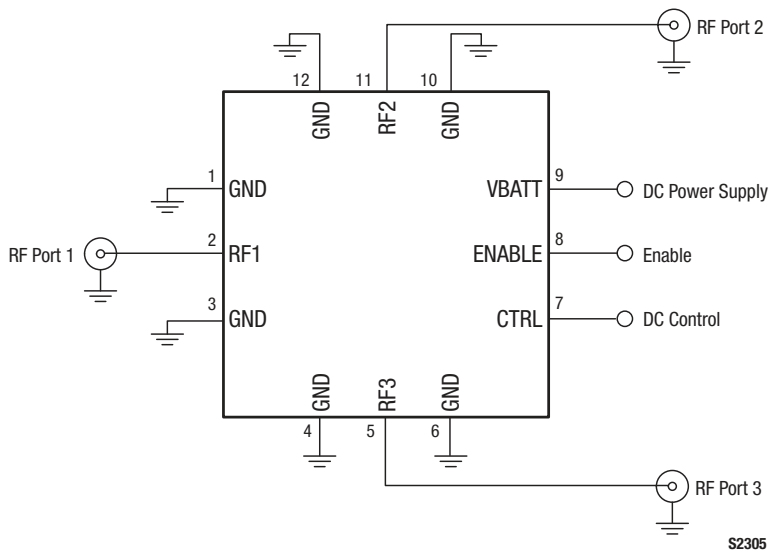

Figure 5. Input to Output Isolation vs Frequency

Evaluation Board Description

The SKY13330-397LF Evaluation Board is used to test the performance of the SKY13330-397LF SP2T Switch.

An Evaluation Board schematic diagram is provided in Figure 6. An assembly drawing for the Evaluation Board is shown in Figure 7.



S2305

Figure 6. SKY13330-397LF Evaluation Board Schematic

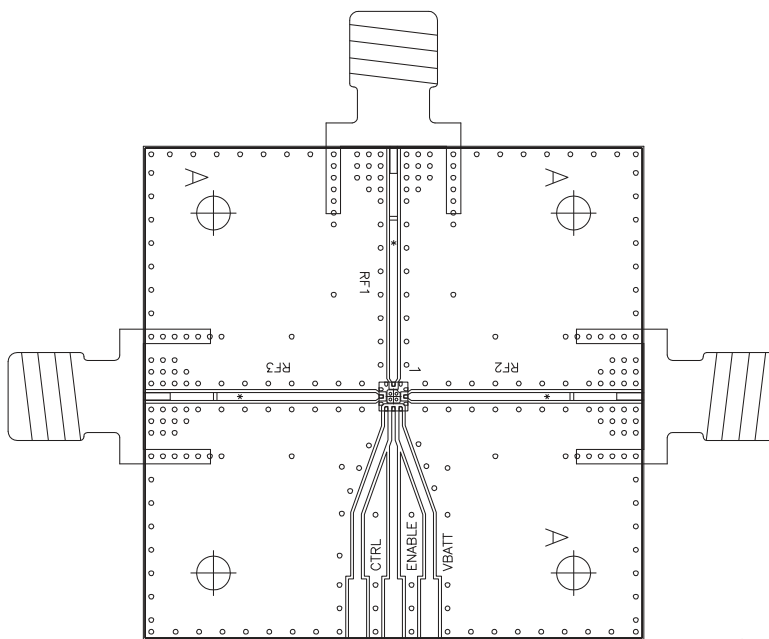

S2217

Figure 7. SKY13330-397LF Evaluation Board Assembly Diagram

Package Dimensions

The PCB layout footprint for the SKY13330-397LF is provided in Figure 8. Typical part markings are shown in Figure 9. Package dimensions are shown in Figure 10, and tape and reel dimensions are provided in Figure 11.

Package and Handling Information

Instructions on the shipping container label regarding exposure to moisture after the container seal is broken must be followed. Otherwise, problems related to moisture absorption may occur when the part is subjected to high temperature during solder assembly.

The SKY13330-397LF is rated to Moisture Sensitivity Level 1 (MSL1) at 260 °C. It can be used for lead or lead-free soldering. For additional information, refer to the Skyworks Application Note, *Solder Reflow Information*, document number 200164.

Care must be taken when attaching this product, whether it is done manually or in a production solder reflow environment. Production quantities of this product are shipped in a standard tape and reel format.

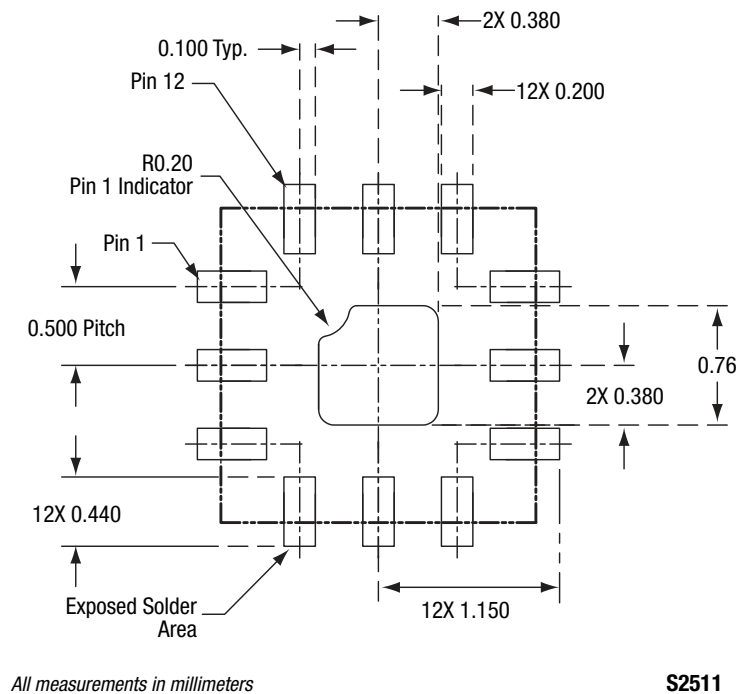

Figure 8. SKY13330-397LF PCB Layout Footprint (Top View)

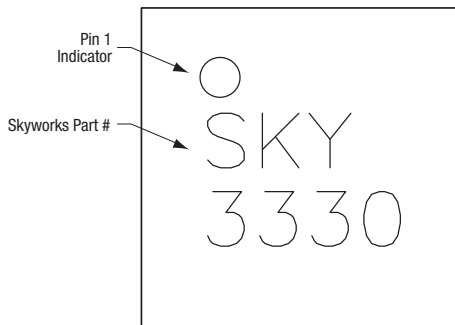
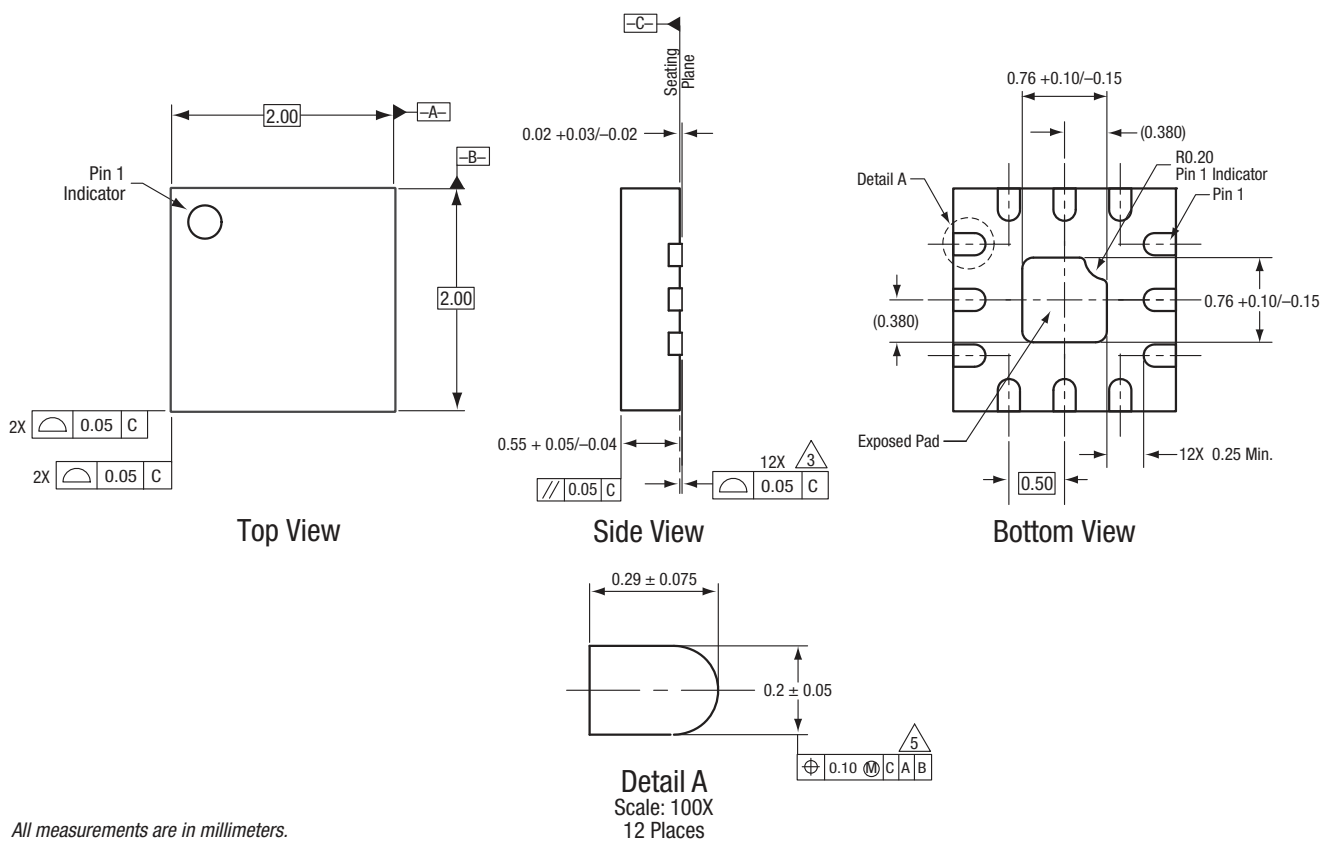

Figure 9. Typical Part Markings (Top View)



All measurements are in millimeters.
 Dimensioning and tolerancing according to ASME Y14.5M-1994.
 Coplanarity applies to the terminals and all other bottom surface metalization.
 Dimension applies to metalized terminal. If the terminal has a radius on its end,
 the width dimension should not be measured in that radius area.
 Contact areas are NiPdAu.

S2512

Figure 10. SKY13330-397LF Package Dimensions

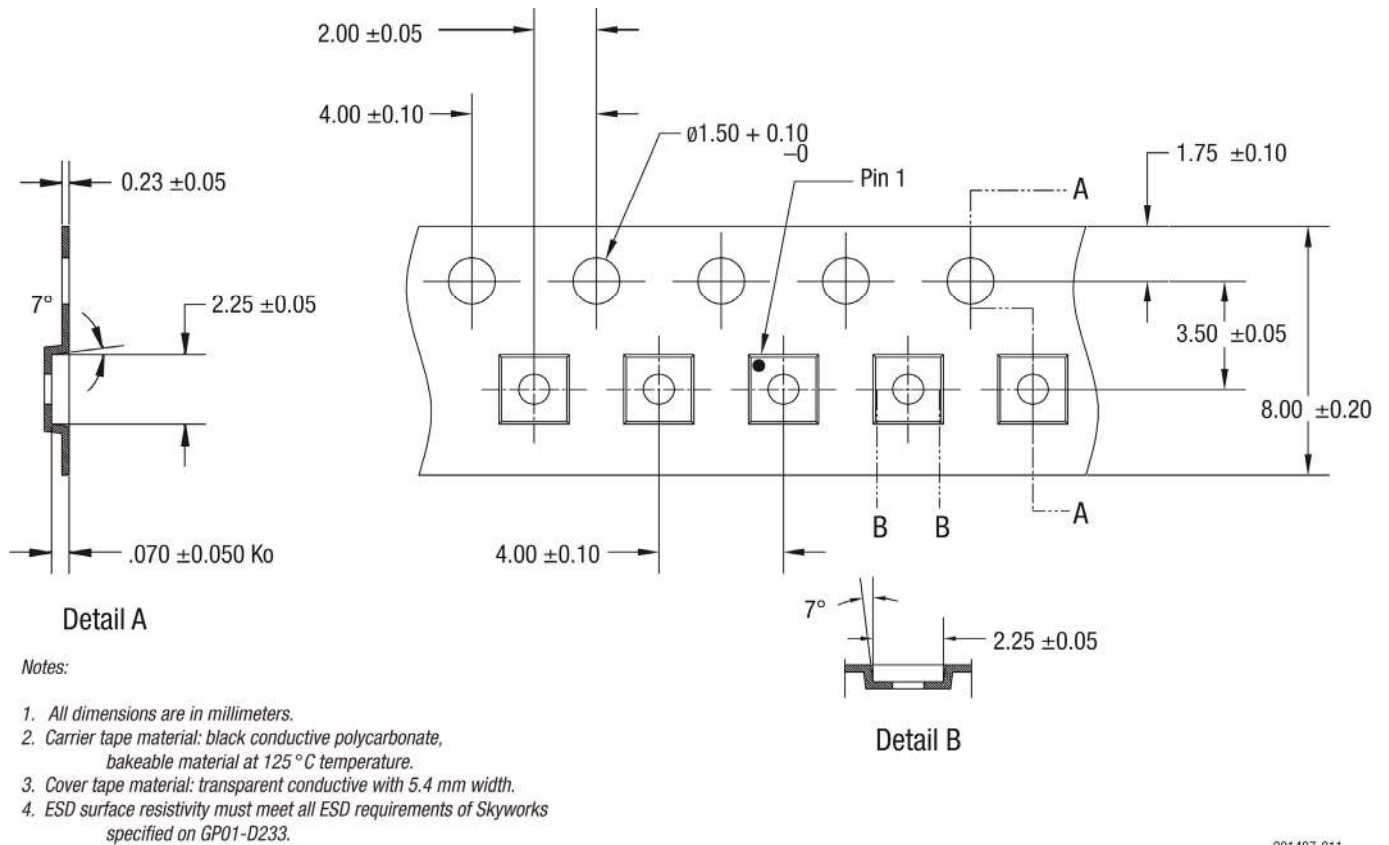

Figure 11. SKY13330-397LF Tape and Reel Dimensions

Ordering Information

Part Number	Product Description	Evaluation Board Part Number
SKY13330-397LF	0.1 to 6.0 GHz SPDT Switch	SKY13330-397LF-EVB

Copyright © 2011-2012, 2019-2020 Skyworks Solutions, Inc. All Rights Reserved.

Information in this document is provided in connection with Skyworks Solutions, Inc. ("Skyworks") products or services. These materials, including the information contained herein, are provided by Skyworks as a service to its customers and may be used for informational purposes only by the customer. Skyworks assumes no responsibility for errors or omissions in these materials or the information contained herein. Skyworks may change its documentation, products, services, specifications or product descriptions at any time, without notice. Skyworks makes no commitment to update the materials or information and shall have no responsibility whatsoever for conflicts, incompatibilities, or other difficulties arising from any future changes.

No license, whether express, implied, by estoppel or otherwise, is granted to any intellectual property rights by this document. Skyworks assumes no liability for any materials, products or information provided hereunder, including the sale, distribution, reproduction or use of Skyworks products, information or materials, except as may be provided in Skyworks Terms and Conditions of Sale.

THE MATERIALS, PRODUCTS AND INFORMATION ARE PROVIDED "AS IS" WITHOUT WARRANTY OF ANY KIND, WHETHER EXPRESS, IMPLIED, STATUTORY, OR OTHERWISE, INCLUDING FITNESS FOR A PARTICULAR PURPOSE OR USE, MERCHANTABILITY, PERFORMANCE, QUALITY OR NON-INFRINGEMENT OF ANY INTELLECTUAL PROPERTY RIGHT; ALL SUCH WARRANTIES ARE HEREBY EXPRESSLY DISCLAIMED. SKYWORKS DOES NOT WARRANT THE ACCURACY OR COMPLETENESS OF THE INFORMATION, TEXT, GRAPHICS OR OTHER ITEMS CONTAINED WITHIN THESE MATERIALS. SKYWORKS SHALL NOT BE LIABLE FOR ANY DAMAGES, INCLUDING BUT NOT LIMITED TO ANY SPECIAL, INDIRECT, INCIDENTAL, STATUTORY, OR CONSEQUENTIAL DAMAGES, INCLUDING WITHOUT LIMITATION, LOST REVENUES OR LOST PROFITS THAT MAY RESULT FROM THE USE OF THE MATERIALS OR INFORMATION, WHETHER OR NOT THE RECIPIENT OF MATERIALS HAS BEEN ADVISED OF THE POSSIBILITY OF SUCH DAMAGE.

Skyworks products are not intended for use in medical, lifesaving or life-sustaining applications, or other equipment in which the failure of the Skyworks products could lead to personal injury, death, physical or environmental damage. Skyworks customers using or selling Skyworks products for use in such applications do so at their own risk and agree to fully indemnify Skyworks for any damages resulting from such improper use or sale.

Customers are responsible for their products and applications using Skyworks products, which may deviate from published specifications as a result of design defects, errors, or operation of products outside of published parameters or design specifications. Customers should include design and operating safeguards to minimize these and other risks. Skyworks assumes no liability for applications assistance, customer product design, or damage to any equipment resulting from the use of Skyworks products outside of stated published specifications or parameters.

Skyworks and the Skyworks symbol are trademarks or registered trademarks of Skyworks Solutions, Inc. or its subsidiaries in the United States and other countries. Third-party brands and names are for identification purposes only, and are the property of their respective owners. Additional information, including relevant terms and conditions, posted at www.skyworksinc.com, are incorporated by reference.