



Li-ion Polymer 290mAh Battery Datasheet

Distributed by TinyCircuits:

TinyCircuits Part Number: ASR00007

Website: <https://tinycircuits.com/>

Company Address: 540 S. Main St Ste 457 Akron, OH 44311 USA

Battery Connector Part: JST SHR-02V-S-B

Battery Mating Connector Part: JST SM02B-SRSS-TB(LF)(SN)

Manufacturing Information:

Company: Shenzhen Hondark Electronics Co., Ltd.

Product Type: Lithium-ion Polymer Battery

Model Name: TY552325-290mAh

USHTS: 8507600020

ECCN: EAR99

Country of Origin: China

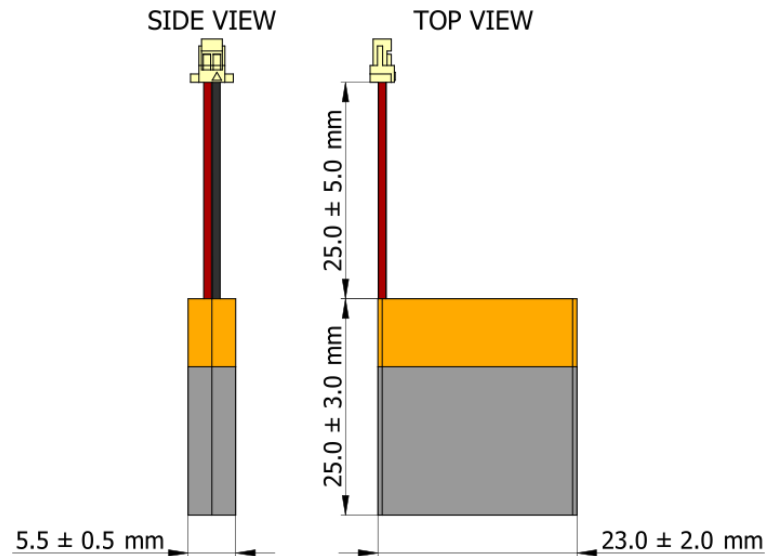

Figure 1: 290mAh Battery Drawing & Dimensions

1. Dimensions and Appearance

1.1 Outline Dimensions: See attached drawing, Figure 1, for dimensions.

Note: The thickness of the battery will swell when stored or used at high temperatures.

1.2 Appearance: The outer surface of the battery is clean, no electrolyte leakage, no obvious scratches and mechanical damage, no deformation, no other appearance defects that affect the value of the battery.

2. Battery Specifications

Table 1: Ratings

No.	Item	Spec.	Unit	Notes
2.1	Normal Capacity	290	mAh	1.0C Discharge
	Minimum Capacity	280	mAh	
2.2	Initial Internal Resistance	≤ 200	m Ω	
2.3	Weight	≈ 5.3	g	
2.4	Nominal voltage	3.7	V	
	Maximum Charge Voltage	4.2	V	
	Minimum Charge Voltage	2.45	V	
2.5	Standard Charge Current	145	mAh	0.5C
2.6	Maximum Charge Current	290	mAh	1.0C
2.7	Maximum Discharge Current	290	mAh	1.0C
2.8	Standard Discharge Current	145	mAh	0.5C
2.9	Charge Cut-off Voltage	4.20	V	
2.10	Discharge Cut-off Voltage	2.45	V	
2.11	Storage Temp. (≤ 1 month)	-20 - +60	$^{\circ}\text{C}$	Percentage of recoverable capacity is no less than 80% of initial capacity.
	(≤ 3 months)	-20 - +45	$^{\circ}\text{C}$	
	(≤ 1 year)	-20 - +28	$^{\circ}\text{C}$	
2.12	Storage Humidity	$\leq 75\%$	RH	
2.13	Standard Testing Condition			Temperature: 23 ± 5 $^{\circ}\text{C}$, Humidity: $\leq 75\%$ RH, Atmospheric Pressure: 86-107KPa

3. General Performance

Item	Measuring Procedure	Standard
(1) 1.0C Capacity	Under standard test conditions, set aside battery for 10minutes after standard charging. Then discharge the battery at 1.0C to 2.45V. Record the discharge time.	≥ 54 min.
(2) Cycle Life	Under standard testing conditions, charge the battery with 0.5C constant current constant to 4.2V. Then constant voltage charge until reaching the cut-off current, 0.01C, set it aside 10min. Then discharge to 2.45V with 0.5C current, leave it for 10 minutes. Repeat the above steps continuously until the discharging capacity is lower than 80% of the Initial Capacity of the Cells.	≥ 300 times.
(3) Charge Retention Capability	Under standard testing conditions, standard charge the battery until fully charged. There is no external load circuit. Rest the battery pack for 28 days, then discharge at 0.2C to 2.45V. Record the discharge time.	≥ 240 min.

4. Environmental Performance

Item	Testing Methods and Conditions	Standard
4.1 High temperature discharge	Under standard testing conditions after standard charging, rest the battery for 4 hours at $50\pm 2^{\circ}\text{C}$. Then discharge at 1.0C to 2.45V. Record the discharge time.	≥ 54 min.
4.2 Low temperature discharge	Under standard testing conditions after standard charging, rest the battery for 4 hours at $-20\pm 2^{\circ}\text{C}$. Then discharge at 1.0C to 2.45V. Record the discharge time.	≥ 210 min.
4.3 Thermal shock	After standard charging, put the battery pack into an oven and raise the temperature in the oven at a rate of $5\pm 2^{\circ}\text{C}/\text{min}$ to $30\pm 2^{\circ}\text{C}$. Keep it at constant temperature for 30 minutes.	No fire, no smoke.

5. Safety Performance

Item	Testing Methods and Conditions	Standard
5.1 Over-Charge Test	Under standard testing conditions, charge pack with constant current 3C to 4.6V. Then with constant voltage 4.6V till current declines to 0mA. Stop test till cells temperature 10°C lower than the max temperature.	No fire, no smoke.
5.2 Over-Discharge Test	Under standard testing conditions, discharge the battery to cut-off voltage. Then connect an external load of 30Ω for 24 hours.	No fire, no smoke, no leakage.
5.3 Short Circuit Test	Under standard testing conditions after standard charging, connect the positive and negative terminals of the battery using a wire with an impedance ≤ 50mΩ for 6 hours.	No fire, no smoke.

6. Protection Circuit

6.1 PCM Standard (Protection Board Standard)

Item	Symbol	Testing Methods and Conditions	Standard
Overcharge Protection	V_{DET1}	Overcharge detection voltage	$4.28 \pm 0.025V$
	tV_{DET1}	Overcharge detection delay time	0.1s
	V_{REL1}	Overcharge release voltage	$4.08 \pm 0.05V$
Overdischarge Protection	V_{DET2}	Overdischarge detection voltage	$2.4 \pm 0.1V$
	tV_{DET2}	Overdischarge detection delay time	110ms
	V_{REL2}	Overdischarge release voltage	$3.0 \pm 0.1V$
Overcurrent Protection	V_{DET3}	Overcurrent detection voltage	$0.2 \pm 0.03V$
	I_{DP}	Overcurrent protection current	2.8A - 3.5A
	tV_{DET3}	Detection delay time	12ms
		Protection release condition	Disconnect load
Short Circuit Protection	T_{SHORT}	Protection condition	External short circuit
		Detection delay time	$\leq 250\mu s$
		Protection release conditions	Break the short circuit
Resistance	R_{DS}	Main circuit on-state resistance	$V_C = 3.6V; R_{DS} \leq 70m\Omega$

7. Schematic Diagram & Table

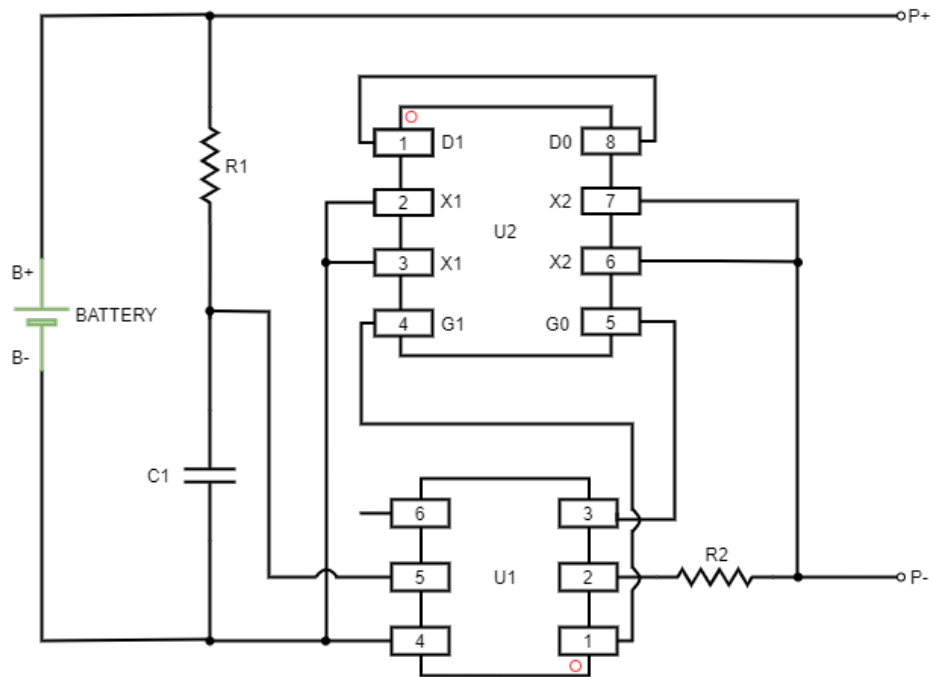

Figure 2: 290mAh Battery Schematic

Table 2: PCM BOM List

No.	Component	Label	Specification	Qty.
1	U1	Battery protection IC	DW01	1
2	U2	Silicon MOSFET	8205A	1
3	R1	Resistance	100Ω±5%	1
4	R2	Resistance	1KΩ±5%	1
5	C1	Capacitance	0.1μF	1

Reference Battery Charging Schematic Diagram & Table

The following schematic and list of parts is implemented in a lithium ion polymer battery charging diagram that is a simplified version of the TinyCircuits Battery Charger, product ASL2112*.

*The ASL2112 is a standalone Lithium battery charger that can be used with a Micro USB B cable. Use the JST SH connector on the ASL2112 board to easily plug-in a battery (compatible batteries sold at <https://tinycircuits.com/>). Alternatively, a battery can be connected without the JST SH connector by using the two through holes, J3 and J4, to connect to a battery pack. To charge a battery with ASL2112, plug the USB B side of the charger into a power source using a compatible cable, and plug a lithium polymer or lithium ion rechargeable (3.7V / 4.2V) battery into the other side. A status LED on the board will indicate when a battery is charging, and the LED will turn off when the battery is fully charged.

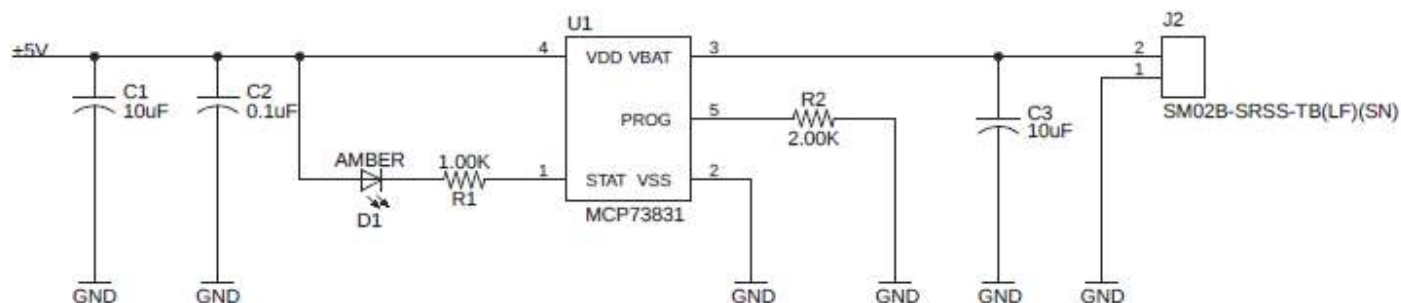

Figure 3: Sample Battery Charger Schematic

Table 3: PCM BOM List

Component	Label	Specification	Notes
IC	U1	MCP73831	
R	R1	1KΩ	
R	R2	2KΩ 2	
C	C1,C3	10μF	
C	C2	0.1μF	
LED Diode	D1	AMBER	Charging Status LED
Connector	J2	JST SM02B-SRSS-TB(LF)(SN)	Compatible Battery Connector: JST SHR-02V-S-B

Handling Instruction and Warnings

Read and observe the following precautions carefully to ensure the correct use of lithium-ion batteries. Our company is not responsible for any problems arising from violation of the following precautions.

Failure to observe the following precautions may result in battery leakage, overheating, explosion and/ or fire.

Battery Environment

- Do not immerse the pack in water, seawater, or other liquids.
- Do not use, or leave the battery near heat sources such as a fire or heater.
- Do not use or store the battery where it is exposed to an extremely hot environment, such as in a car under direct sunlight or on a hot day. Otherwise, the battery will overheat and may catch fire (ignite). This can also reduce battery performance and/or shorten service life.
- Do not place the battery in a microwave oven or pressurized container.
- Do not use the battery in a location where static electricity or magnetic fields are great, otherwise, the safety devices in the pack may be damaged, which may cause unsafe risks.
- Keep the batteries out of the reach of young children. If a child somehow swallows a battery, seek medical attention immediately. In cases where children use the battery, instruct them on the contents of this document and supervise them to ensure that the battery is being used correctly.
- Use the battery only under the environmental conditions mentioned in this document. Failure to do so can result in reduced performance or a shorten service life. Using the battery outside this temperature range can cause the battery to overheat, explode or catch fire.

Aluminum Foil Flexible Packaging

- The aluminum foil flexible packaging encasing the battery cells is vulnerable to sharp objects that could puncture or damage the integrity of the aluminum.
- Do not transport or store the battery together with metal objects such as keys, necklaces etc.
- Do not strike at pack with any sharp objects. The soft aluminum packing foil may be easily damaged by sharp edge parts such as Ni-tabs, pins and needles.
- Do not strike the battery with any sharp-edged parts.
- Trim nails or wear gloves before handling batteries.
- Clean worktable where battery is used to avoid any sharp objects.
- Polymer batteries have lower mechanical durability than metal shell prismatic batteries. Drops, collisions, bending, etc. may reduce the performance of polymer batteries.

Battery Electrolyte

- If the pack leaks and the electrolyte get into the eyes, do not rub eyes. Instead, rinse the eyes with clean running water, and immediately seek medical attention. Otherwise, eye injury may result.
- If the battery leaks and electrolyte gets on your skin or clothing, immediately rinse the affected area with clean running water. If left as is, skin inflammation can occur.

- Pay attention to the use of insulation structures between the battery core (the exposed aluminum layer on the side and the top edge of the package sealing film) and the PCB, as well as between the battery core and electrical appliances. Pay special attention to the insulation between the aluminum layer and positive and negative terminals of the battery. Contact of the poles and aluminum layer or electrical equipment may cause battery leakage or swelling.
- If the battery leaks or emits an odor, immediately remove it from the proximity of any exposed flame. The leaking electrolyte can ignite and cause a fire or explosion.

Prohibit Short Circuit

- A short circuit will generate high current and may cause the battery to generate heat, leak electrolyte, smoke, and/or explode.
- Do not short-circuit the pack by connecting the positive and negative terminals directly, or by using conductive materials such as metal wire.
- Short circuiting is very dangerous. The battery tabs may be short-circuited by putting them on a conductive surface. An external short circuit such as this may lead to heat generation and damage to the battery.

Electrical Application

- Do not use the battery in combination with batteries of different capacity, type, or brand.
- Do not attempt to disassemble or modify the battery in any way.
- Do not use any chargers other than those recommended for Lithium-ion Polymer batteries. Consider using TinyCircuits' Battery Charger product ASL2112.
- Do not reverse the positive (+) and negative (-) terminals.
- Do not connect the pack to an electrical outlet, such as wall outlets or car cigarette-lighter sockets.
- Do not directly solder the pack or battery terminals.
- If the pack emits an odor, generates heat, becomes discolored or deformed, or any abnormal phenomenon occurs during charging, recharging or storage, immediately remove the battery from the charger or device, and stop use.
- If the case pack terminals are dirty, clean the terminals with a dry cloth before use. Otherwise power failure or charge failure may occur due to the poor connection with the instrument.
- Be aware that discharged battery may cause fire or smoke; tape the terminals with insulating paper to insulate them.
- For directions on battery installation and removal, read the instruction manual that accompanies the equipment in which the battery will be used.
- The load circuit may generate voltage and current, which will be reversed to the battery pack (including PCM). The voltage and current cannot exceed the reverse withstand voltage (RWV) and current (RWI) value of the protection board itself. High voltage or current can damage the protection board in the battery pack.

Storage

If a device is not used for an extended period, the battery should be removed and stored in a cool, dry place. Otherwise, resting, or reduced performance may occur.

The pack should be stored at room temperature, charged to about 40% to 60% of capacity. In case of over-discharge, a pack should be charged once every 3 months while storing and batteries should be discharged and charged after being stored more than a year in order to activate and restore energy.

Vendor Notes

The customer is requested to contact TinyCircuits in advance, if and when the customer needs other applications or operating conditions than those described in this document. Additional experimentation may be required to verify performance and safety under such conditions.

TinyCircuits will take no responsibility for any accident when the battery is used under other conditions than those described in this Document.

TinyCircuits will inform, in a written form, the customer of improvement(s) regarding proper use and handling of the battery, if it is deemed necessary.

Any matters that this specification does not cover should be conferred between the customer and TinyCircuits.

Period of Warranty

The period of warranty is 90 days from the date of shipment. If you find that the product does not perform to specifications at any time within ninety (90) calendar days of purchase, TinyCircuits will gladly replace the defective product. If the problem is caused by the user's misuse, it will not be replaced.

Amendment of this Specification

The company, TinyCircuits, has the right to revise this product specification. After revising the product specification, our company will notify the customer.