

### Features

- ➔ High-speed path can switch differential signals such as TMDS or LVDS
- ➔  $V_{DD} = 3.3V \pm 10\%$
- ➔ ESD tolerance on video I/O pins is up to 12kV HBM
- ➔ -3dB BW of 1.7GHz, 3.4Gbps
- ➔ Low Xtalk, (-73dB typ)
- ➔ Low and Flat ON-STATE resistance ( $R_{on} = 3.5\text{-ohm}$ ,  $R_{on(Flat)} = 0.15\text{-ohm}$ , typ)
- ➔ Low input/output capacitance ( $C_{in} = 7.5\text{pF}$ , typ)
- ➔ Packaging (Pb-free and Green):
  - 56 contact TQFN (ZFE)

### Description

Pericom's PI3LVD400 is a 4-differential channel high-speed switch used for LVDS or TMDS signals. The PI3LVD400 can be used to switch between multiple LVDS sources or end points. In a notebook application where analog video signals are found in both the notebook and the dock, a switch solution is required to switch between the two video port locations. With the high bandwidth of 1.7GHz, the signal integrity will remain strong even through the long FR4 trace between the notebook and the docking station. The device also offers the user a secondary path for DDC signals. This DDC path can be used for both switching as well as voltage translation from 5V down to 3.3V. In addition to high signal performance, the video signals are also protected against high ESD with integrated diodes to  $V_{DD}$  and GND that will support up to 12kV of ESD HBM protection.

### Packaging Mechanical: 56-Contact TQFN

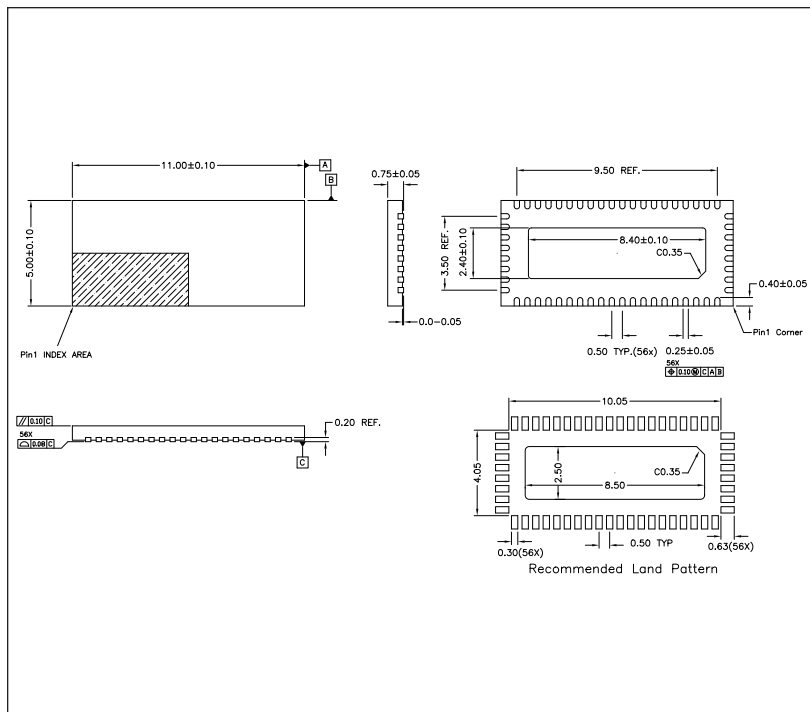

### Block Diagram

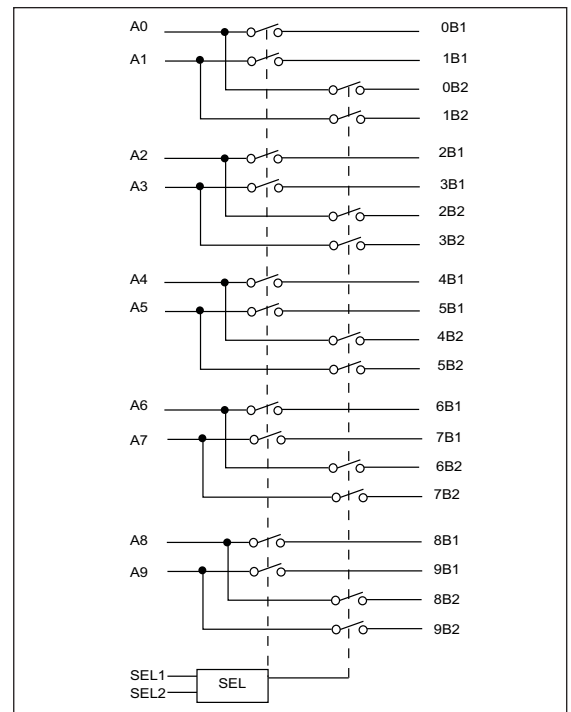

### Ordering Information

Ordering Code	Package Code	Package Type
PI3LVD400ZFE	ZF	Pb-free and Green 56-Contact TQFN

1. Thermal characteristics can be found on the company web site at [www.pericom.com/packaging/](http://www.pericom.com/packaging/)
2. E = Pb-free and Green
3. Adding an X Suffix = Tape/Reel