

THIS DRAWING IS UNPUBLISHED. RELEASED FOR PUBLICATION
 © COPYRIGHT BY TYCO ELECTRONICS CORPORATION. ALL RIGHTS RESERVED.

LOC	DIST	REVISIONS					
AJ	00	P	LTR	DESCRIPTION	DATE	DWN	APVD
		B		REV PER ECO 07-004710	2/27/2007	DW	KW

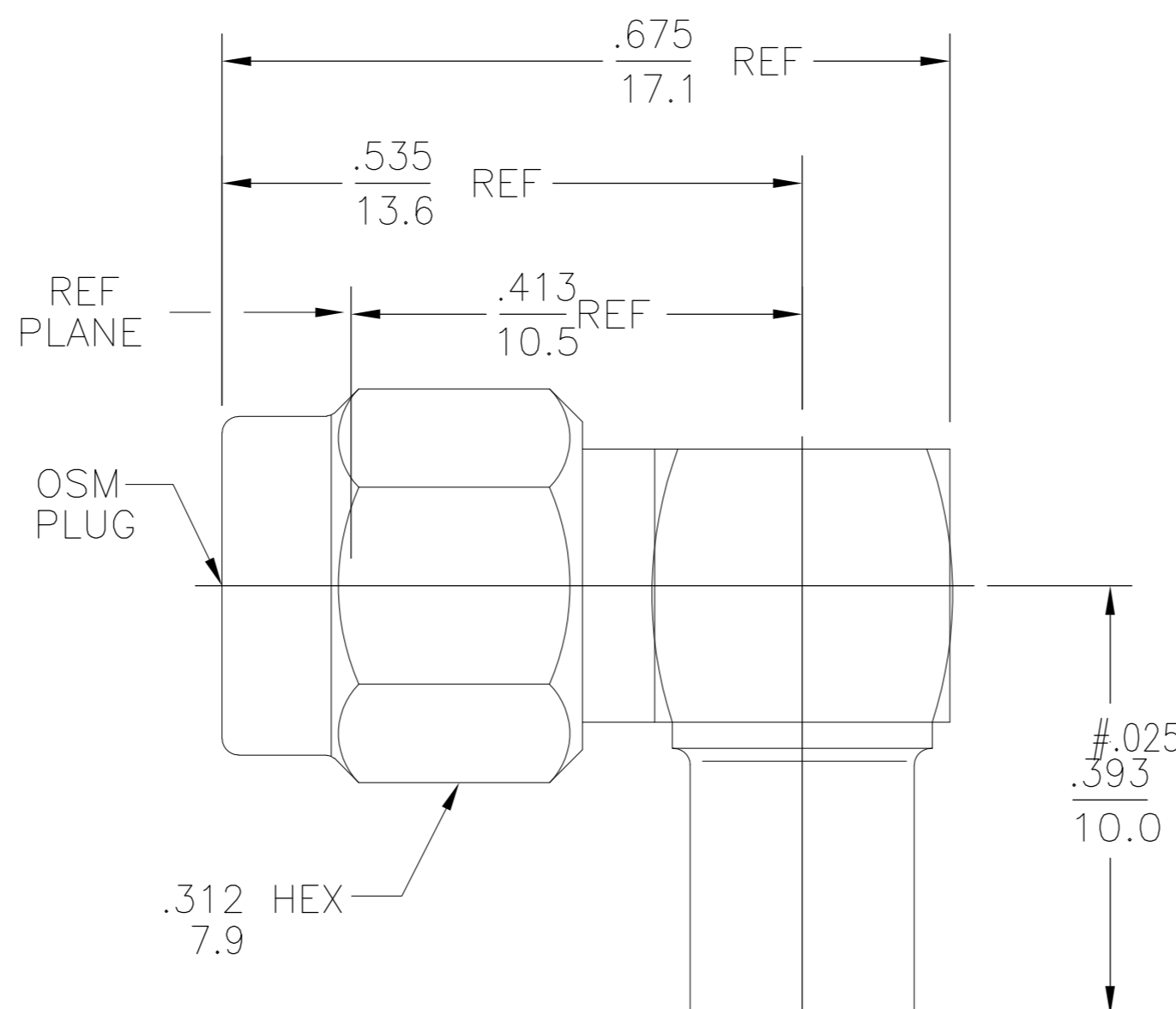

1051129-1
 PART NUMBER

HOUSING COUPLING NUT CAP	STAINLESS STEEL PER ASTM-A484 AND ASTM- A582, TYPE 303	GOLD PLATE PER MIL-G-45204
DIELECTRIC	TFE FLUOROCARBON PER ASTM-D-1457	N/A
CENTER CONTACT	BERYLLIUM COPPER PER ASTM-B-196 ALLOY C17300, CONDITION H, OR BRASS PER ASTM-B-16	GOLD PLATE PER MIL-G-45204
RETAINING RING	BERYLLIUM COPPER PER ASTM-B-194, ALLOY C17200, CONDITION H	N/A
GASKET	SILICONE RUBBER PER ZZ-R-765	N/A
COMPONENT	MATERIAL	FINISH

THIS DRAWING IS A CONTROLLED DOCUMENT.		DWN <i>JKR</i>	11/15/95	tyco Electronics	Tyco Electronics Corporation Harrisburg, PA 17105-3608	
DIMENSIONS: INCHES		CHK -	-		NAME OSM RIGHT ANGLE CABLE-DIRECT SOLDER ATTACHMENT	
TOLERANCES UNLESS OTHERWISE SPECIFIED:		APVD <i>Domell</i>	11/15/95	SIZE A2		
0 PLC ± -		PRODUCT SPEC	-	CAGE CODE 00779		
1 PLC ± -		APPLICATION SPEC	-	DRAWING NO C=1051129		
2 PLC ± -		WEIGHT	-	RESTRICTED TO -		
3 PLC ± .005		CUSTOMER DRAWING		SCALE 5:1		
4 PLC ± -		SHEET		1 of 1		
ANGLES ± 1°		REV		B		
FINISH		-		-		