

APPROVED: _____
 DATE: _____ TITLE: _____

Rev	AWO #	Description	Date	Appr
-		RELEASED	1/14/11	
A		ADDED SPEC.	7/25/11	
B		UPDATE SPEC.	11/11/19	AY/EY

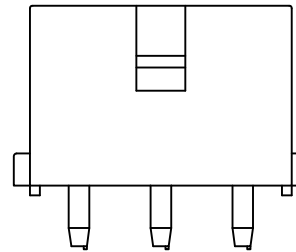
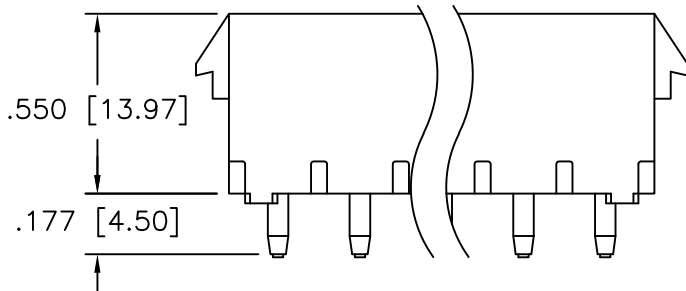
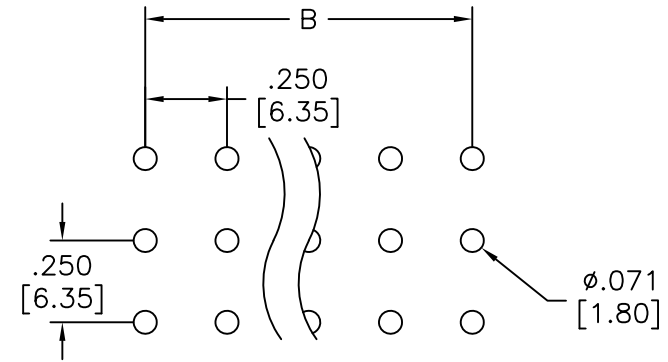
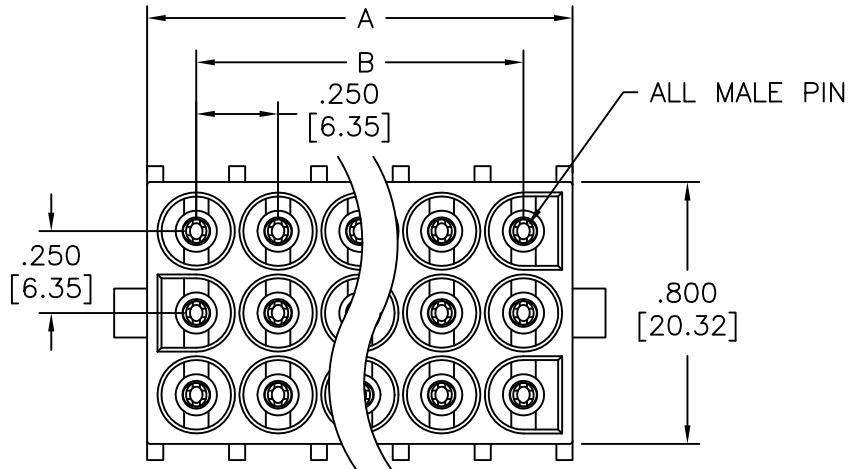

SPECIFICATIONS:

Material:
 Insulator: Nylon 66, rated UL 94V-0
 Insulator color: White
 Contacts: Phosphor Bronze, Tin plated
 Electrical:
 Operating voltage: 600 VAC max
 Current rating: 13 Amps max.
 Insulation resistance: 1000 Mohms min @ 500 VDC
 Dielectric withstanding voltage: 5000 VAC for 1 minute
 Temperature Rating:
 Operating temperature: -55°C to +105°C
 Environmental:
 Lead free, RoHS compliant.



$A = .250 [6.35] \times \text{No. of Positions} + .050 [1.27]$
 $B = .250 [6.35] \times \text{No. of Spaces}$

UNLESS OTHERWISE SPECIFIED ALL DIMENSIONS ARE MM [INCHES] TOLERANCES: EXCEPT AS NOTED		ADAM TECH		909 Rahway Avenue, Union, NJ 07083 Phone: 908-687-5000 Fax: 908-687-5710	
INCHES		HOLES		TITLE WIRE TO BOARD, FEMALE, 6.35mm PITCH WITHOUT POLARIZING	
.X ± .10	Ø.X ± .10	.XX ± .020	Ø.XX ± .015		
.XXX ± .015	Ø.XXX ± .010			REV. B	
APPROVALS		DATE		REF: S000123T SCALE: NTS SHEET 1 OF 2	
DRAWN	DY	1/14/11			
CHECKED				SIZE X PART NO. DME-XX-S-SQ-V0	
APPROVED					

6 5 4 3 2 1

D

D

C

C

B

B

A

A

6 5 4 3 2 1

6

5

4

3

2

1

APPROVED: _____

DATE: _____ TITLE: _____

Rev	AWO #	Description	Date	Appr
-----	-------	-------------	------	------

SEE SHT 1 OF 2 FOR REVISION

D

C

B

A

D

C

B

A

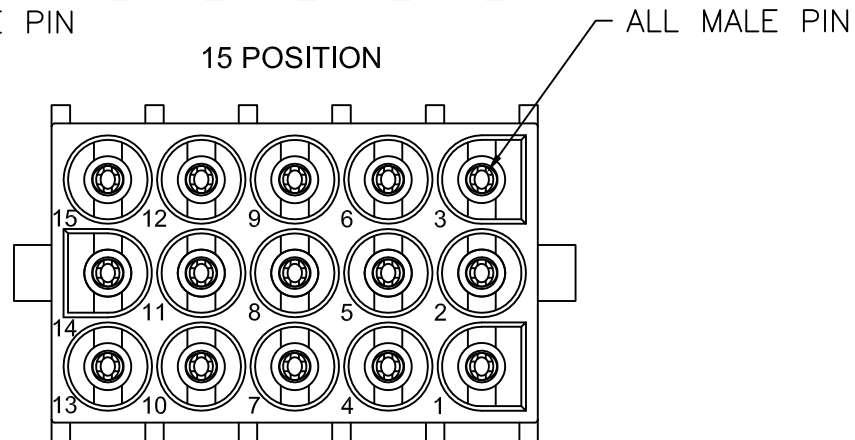
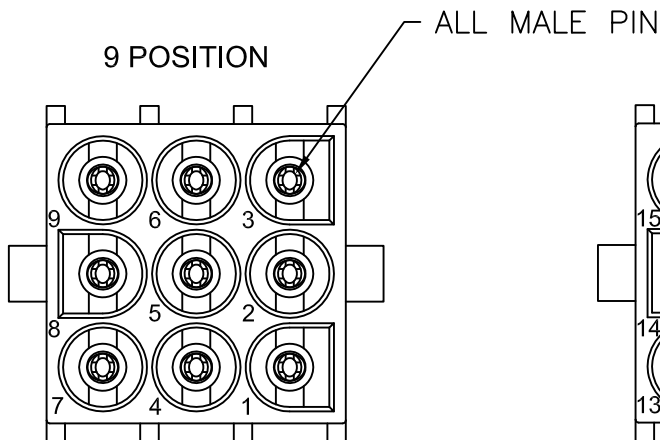
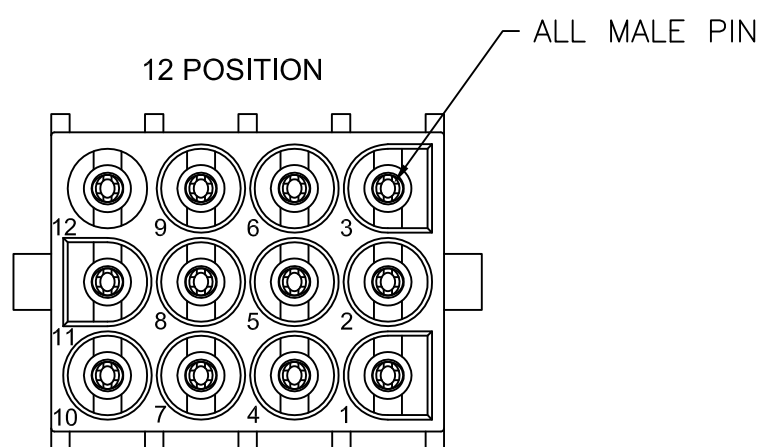
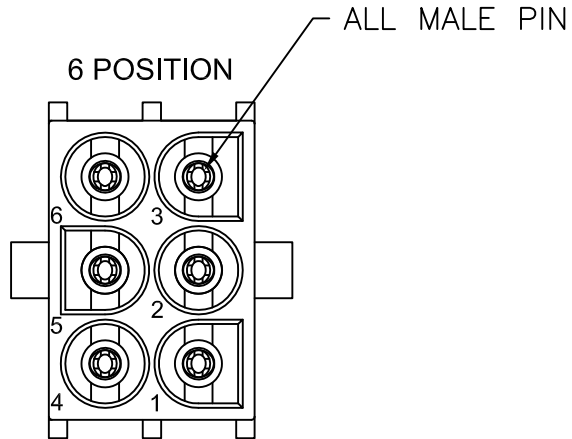

UNLESS OTHERWISE SPECIFIED
 ALL DIMENSIONS ARE INCHES [MM]
 TOLERANCES: EXCEPT AS NOTED
 INCHES HOLES
 .X ± .10 Ø.X ± .10
 .XX ± .020 Ø.XX ± .015
 .XXX ± .015 Ø.XXX ± .010

ADAM
TECH
INTERCONNECTS

909 Rahway Avenue,
 Union, NJ 07083
 Phone: 908-687-5000
 Fax: 908-687-5710

APPROVALS		DATE
DRAWN	DY	1/14/10
CHECKED		
APPROVED		

TITLE
 WIRE TO BOARD, FEMALE, 6.35mm PITCH
 WITHOUT POLARIZING

SIZE X	PART NO. DME-XX-S-SQ-V0	REV. B
REF: S000123T	SCALE: NTS	SHEET 2 OF 2

6

5

4

3

2

1