

5

4

3

2

1

Mating face according to : MIL-C-24308 / DIN 41652 / CECC 75301-802

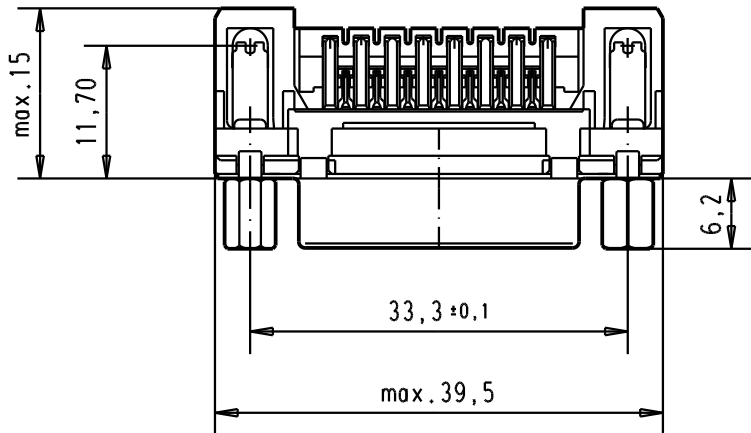
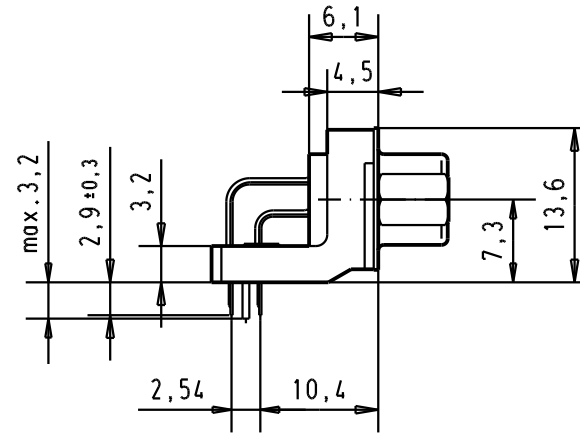
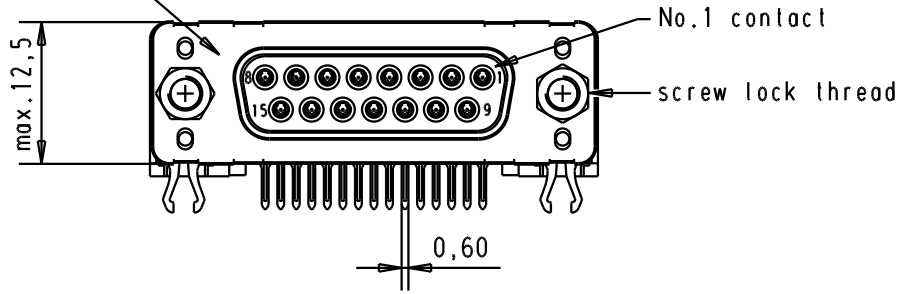

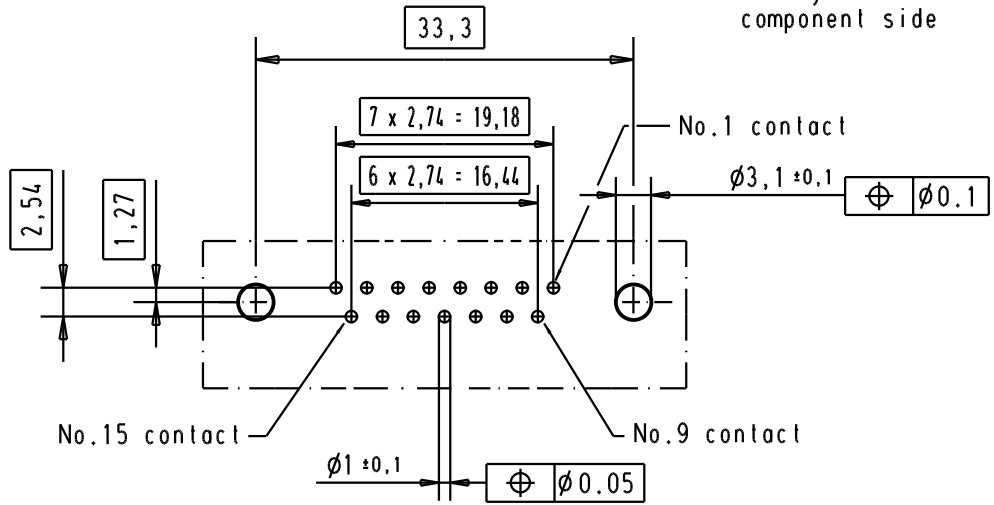

PCB layout hole component side

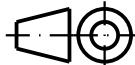

Connector retention and insertion forces on the PCB = 25 / 80 newtons

A

| | | | | | | | | | | | | | |
|----------------|-------------------|-------------------|-------|----------|------|-------------------------------|--------|------|---|----|---|--|----------------------------|
| 09 66 252 3633 | M3 | 1 | | | | | | | | | | | |
| 09 66 252 6633 | M3 | 2 | | | | | | Det. | 4-SEP-02 | YT |  All Dim. in mm Orig. Size DIN A 4 | D-Sub 15 poles standard angle female, solder pin with screw lock and grounding board lock. | Maßstab/ Scale 1.5:1 |
| 09 66 252 7633 | M3 | 3 | | | | | Insp. | | | | | | |
| 09 66 252 3613 | 4-40 UNC | 1 | | | | | Stand. | | | | | | |
| 09 66 252 6613 | 4-40 UNC | 2 | 31892 | 05/05/04 | JH | HARTING EURL F-95972 Paris | | |  | | TB 0966252x6x3 | Blatt/ Page 1 / 1 | |
| 09 66 252 7613 | 4-40 UNC | 3 | 31084 | 4-SEP-02 | YT | | | | | | | | |
| Part number | Screw lock thread | Performance level | Mod. | Dat. | Name | | | | Sub. | | | | |