

# EM280



## Multi-channel power analyzer



### Description

Multi-channel power analyzer for single or three-phase systems installable on panels or DIN rails. Manages current input up to 32 A via a 6-channel current transformer block (TCD06BS with split core or TCD06BX with solid core) connected with RJ-11 connectors.

The EM280 is equipped with a LCD display with controls to display measurements and configure the system, a RS485 port and two pulse outputs or two RS485 ports for daisy chain connections. Thanks to the SUM function, it also displays total load consumption values.

### Benefits

- **Reduced installation time and errors.** Equipped with detachable terminals for all connections, with possibility of requesting pre-wired cables (optional). Connected to the 6-channel current transformer block with two cables fitted with RJ-11 connectors. For connections in cascade of multiple EM280s the voltage reference is required once only.
- **Compact dimensions.** It uses a compact current transformer block (TCD06BS or TCD06BX) that performs the function of six transformers, observing the standard dimensions of the switches for DIN rails.
- **Installation flexibility.** It can be installed in new or existing single- and three-phase systems. Suitable for panel or DIN rail mounting .
- **Granular analysis.** It provides total measurements or single load measurements (up to 2 three-phase loads or up to 6 single-phase loads).
- **Specific software.** The UCS proprietary configuration software enables rapid configuration and the display of all measurements. The software and subsequent updates are free.
- **Tamper-proof.** Configuration access can be locked. The terminals and display can be sealed.

### Applications

EM280 is connected directly on output from the switches present in switchboards for simultaneous monitoring of multiple single- or three-phase loads in low voltage systems.

Created for both commercial and industrial environments (e.g. data centers), this device guarantees quick and space-saving installations with just a few simple connections.

Suitable for new installations with little space available (using the transformer block TCD06BX), and for existing or new installations where more installation flexibility is required (using transformer block TCD06BS).

### Main functions

- Measurement of energy consumption and main electrical variables of single- or three-phase loads.
- Display of single load measurements and total measurements
- Transmission of data via serial communication.
- Transmission of power consumption via pulse output (optional).

## Architecture (example with transformer block TCD06BX)

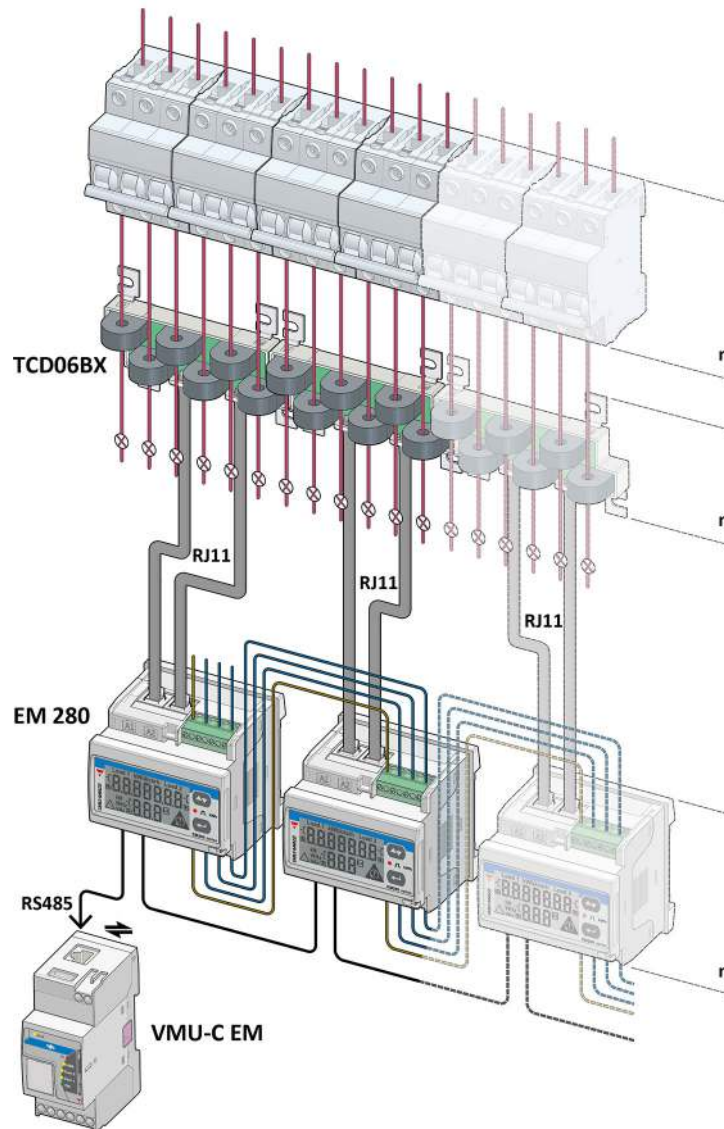

## Main features

- Up to 2 three-phase loads or 6 single-phase loads managed simultaneously.
- Up to 32 A input current via 6-channel transformer block TCD06BS or TCD06BX.
- Three installation configurations: on DIN rails, mounted on panel of 72 x 72 or 96 x 96 (with optional adapter).
- Single load measurements: V, A, W/VA/var, kWh, kvarh. Total load measurements: W/VA/var, kWh, kvarh.
- Display of electrical variables: 3 digits. Display of energy meters: 7 digits.
- Accuracy: better than a combination of a class 1 meter and a class 0.5 current transformer.
- *Easy connection* function.
- Up to 20 EM280 connected in cascade.
- RS485 port.
- Optional outputs: additional RS485 port for chain connection or two pulse outputs.
- Self power supply via voltage inputs.
- Detachable terminals and sealable terminal caps.
- Configuration via keypad or UCS configuration software.

## Structure

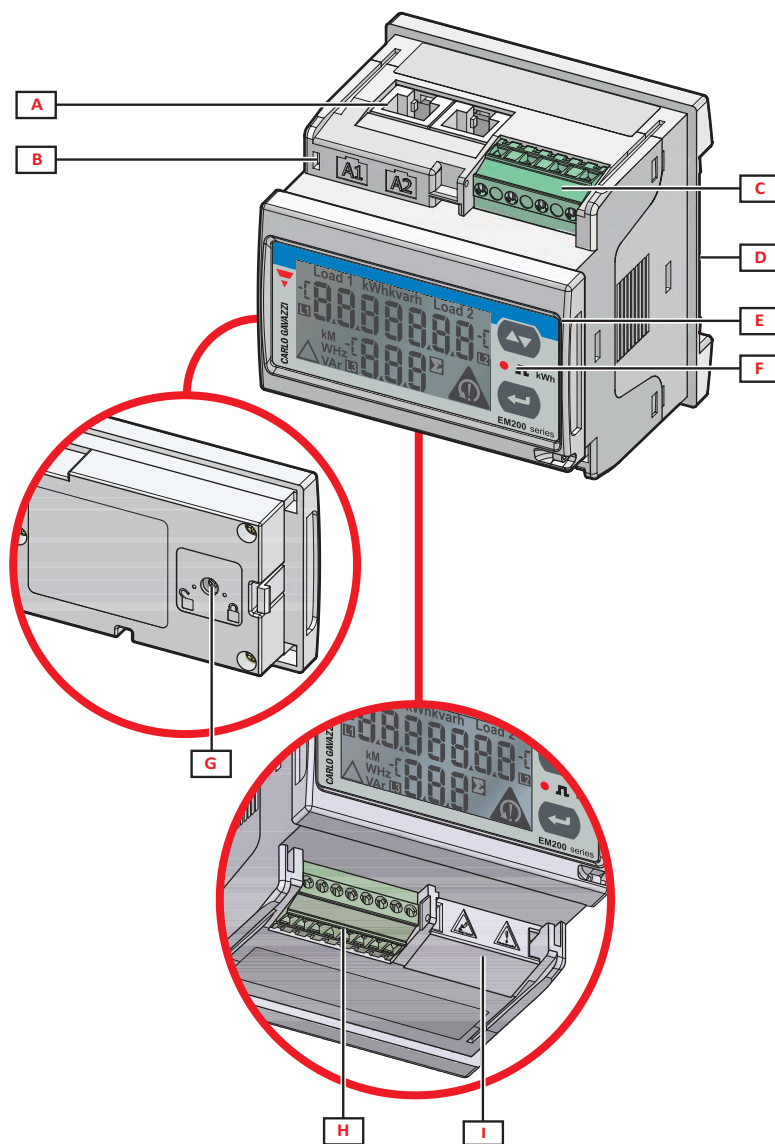

Area	Description
A	RJ-11 connector for connection to transformer block.
B	Power supply status LED.
C	Detachable voltage input terminals.
D	Area for mounting on DIN rail or for housing the LCD display in the case of panel mounting.
E	LCD display and controls.
F	LED that blinks with frequency proportional to active energy consumption, see "LED features".
G	Rotary selector to lock configuration.
H	RS485 port terminals and pulse outputs.
I	Plastic protection cover or terminals for voltage connection in cascade.

## Features

### General

<b>Material</b>	Noryl, self-extinguishing V-0 (UL 94)
<b>Protection degree</b>	Front: IP40, Terminals: IP20
<b>Terminals</b>	Type: detachable Maximum section: 1.5 mm <sup>2</sup> , Torque: 0.2/0.25 Nm
<b>Overvoltage category</b>	Cat. III
<b>Pollution degree</b>	2
<b>Noise rejection (CMRR)</b>	100 dB, from 48 to 62 Hz
<b>Insulation</b>	See "Input and output insulation"
<b>Mounting</b>	DIN rail Panel 72 x 72, Panel 96 x 96 (with optional adapter)
<b>Weight</b>	400 g (packaging included)

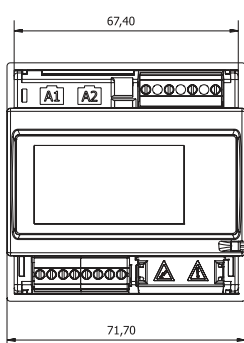

Fig. 1 DIN rail

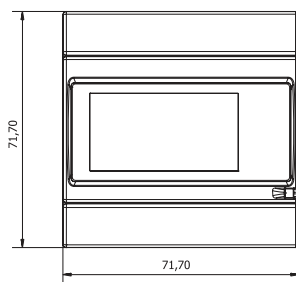
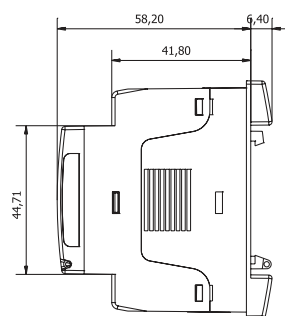
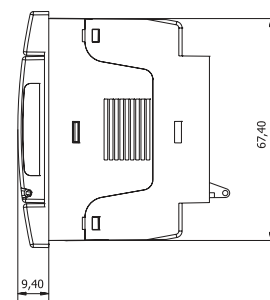

Fig. 2 Panel 72 x 72



### Environmental specifications

<b>Operating temperature</b>	From -25 to +55 °C/from -13 to +131 °F
<b>Storage temperature</b>	From -30 to +70 °C/from -22 to +158 °F

NOTE: R.H. < 90 % non-condensing @ 40 °C / 104 °F.



### Input and output insulation

Type	Voltage input and self power supply	Current input (TCD06B output)	Pulse outputs	RS485 port
<b>Voltage input and self power supply</b>	-	Reinforced *	Double **	Double **
<b>Current input (TCD06B output)</b>	Reinforced *	-	Double **	Double **
<b>Pulse outputs</b>	Double **	Double **	-	-
<b>RS485 port</b>	Double **	Double **	-	-

\*By limiting impedance

\*\*2.5 kV ac 1 min (4 kV pk 1.2/50 μs)+ limiting impedance

## Conformity

<b>Directives</b>	2014/35/EU (LVT - Low Voltage) 2014/30/EU (EMC - Electro Magnetic Compatibility) 2011/65/EU (Electric-electronic equipment hazardous substances)
<b>Standards</b>	Electromagnetic compatibility (EMC) - emissions and immunity: EN62052-11 Electrical safety: EN61010-1 Pulse outputs: IEC62053-31, DIN43864
<b>Approvals</b>	 

## Electrical specifications

### Electrical system and loads

<b>Managed electrical system</b>	Single-phase (2-wire) Three-phase without neutral (3-wire) Three-phase with neutral (4-wire)
<b>Number of loads managed</b>	Single-phase systems: up to 6 single-phase loads Three-phase systems: up to 2 three-phase loads or up to 6 single-phase loads

### Voltage inputs

	MV5	MV6
<b>Voltage connection</b>	Direct	
<b>Rated voltage L-N (from Un min to Un max)</b>	From 160 to 240 V	From 57.7 to 133 V
<b>Rated voltage L-L (from Un min to Un max)</b>	From 277 to 415 V	From 100 to 230 V
<b>Voltage tolerance</b>	-15%, +10%	
<b>Overload</b>	Continuous: 1.2 Un max For 500 ms: 2 Un max	
<b>Input impedance</b>	1600 kΩ	
<b>Frequency</b>	From 45 to 65 Hz	

### Current inputs

<b>Current connection</b>	Via transformer block TCD06BS or TCD06BX
<b>Primary current</b>	Automatic setting of primary current of connected TCD06B
<b>Rated current (In)</b>	32 A (primary current of TCD06BS or TCD06BX)
<b>Minimum current (Imin)</b>	0.02 In
<b>Maximum current (Imax)</b>	1.2 In
<b>Start-up current (Ist)</b>	0.002 In
<b>Overload</b>	Continuous: 1.2 In For 500 ms: 2 In
<b>Input impedance</b>	< 0.2 VA

## Power supply

<b>Power supply</b>	Self powered, between L2 and L3
<b>Consumption</b>	2 W, ≤ 4 VA

## Measurements

<b>Method</b>	TRMS measurements of distorted waveforms
<b>Sampling</b>	1600 samples/s @50 Hz 1900 samples/s @60 Hz

## Available measurements

### Three-phase loads

<b>Energy</b>	Active imported Reactive imported
<b>Current</b>	Phase 1 Phase 2 Phase 3
<b>Voltage</b>	Phase-phase Phase-neutral
<b>Active power</b>	Total load Average (dmd) Maximum dmd
<b>Apparent power</b>	Total load Average (dmd) Maximum dmd
<b>Reactive power</b>	Total load

### Single-phase loads

<b>Energy</b>	Active
<b>Current</b>	Phase
<b>Voltage</b>	Phase-neutral
<b>Active power</b>	Total load Average (dmd) Maximum dmd

## Measurement accuracy

### EM280

Current	
From 0.05 I <sub>n</sub> to I <sub>max</sub>	±(0.5% rdg)
From 0.02 I <sub>n</sub> to 0.05 I <sub>n</sub>	±(1.0% rdg)
Phase-phase voltage	
From (U <sub>n</sub> min -10%) to (U <sub>n</sub> max +10%)	±(0.5% rdg)
Phase-neutral voltage	
From (U <sub>n</sub> min -10%) to (U <sub>n</sub> max +10%)	±(1% rdg)
Active power (PF=1)	
From 0.05 I <sub>n</sub> to I <sub>max</sub>	±(1% rdg)
From 0.02 I <sub>n</sub> to 0.05 I <sub>n</sub>	±(1.5% rdg)
Active power (PF=0.5L, 0.8C)	
From 0.1 I <sub>n</sub> to I <sub>max</sub>	±(1% rdg)
From 0.05 I <sub>n</sub> to 0.1 I <sub>n</sub>	±(1.5% rdg)
Reactive power (sinφ=1)	
From 0.05 I <sub>n</sub> to I <sub>max</sub>	±(2% rdg)
From 0.02 I <sub>n</sub> to 0.05 I <sub>n</sub>	±(2.5% rdg)
Reactive power (sinφ=0.5 L or C)	
From 0.1 I <sub>n</sub> to I <sub>max</sub>	±(2% rdg)
From 0.05 I <sub>n</sub> to 0.1 I <sub>n</sub>	±(2.5% rdg)
Reactive power (sinφ=0.25 L o C)	
From 0.1 I <sub>n</sub> to I <sub>max</sub>	±(2.5% rdg)
Active energy	
Equivalent to class 1 (EN62053-21)	
Reactive energy	
Equivalent to class 2 (EN62053-23)	
Frequency	
From 45 to 65 Hz	±1 Hz

### EM280+TCD06BX or EM280+TCD06BS

Current	
From 0.2 I <sub>n</sub> to I <sub>max</sub>	±(0.75% rdg)
From 0.05 to 0.2 I <sub>n</sub>	±(1% rdg)
From 0.02 I <sub>n</sub> to 0.05 I <sub>n</sub>	±(1.25% rdg)
Active power (PF=1)	
From 0.2 I <sub>n</sub> to I <sub>max</sub>	±(1.25% rdg)
From 0.05 to 0.2 I <sub>n</sub>	±(1.5% rdg)
From 0.02 I <sub>n</sub> to 0.05 I <sub>n</sub>	±(2% rdg)
Reactive power (sinφ=1)	
From 0.2 I <sub>n</sub> to I <sub>max</sub>	±(2.25% rdg)
From 0.05 to 0.2 I <sub>n</sub>	±(2.5% rdg)
From 0.02 I <sub>n</sub> to 0.05 I <sub>n</sub>	±(3% rdg)

## Display

<b>Type</b>	LCD
<b>Refresh time</b>	1 s
<b>Description</b>	2 rows: 1 <sup>st</sup> : 7 digits (7 mm) 2 <sup>nd</sup> : 3 digits (7 mm)
<b>Variable readout</b>	Electrical variables: 3 digits, min: 0.00, max: 999 Energy meters: 7 digits, min: 0.0, max: 9 999 999

## Digital outputs

<b>Connection type</b>	Detachable terminals
<b>Maximum number of outputs</b>	2
<b>Type</b>	Opto-mosfet
<b>Function</b>	Pulse output. Each output transmits the consumption of a single three-phase load or the total consumption of three single-phase loads.
<b>Features</b>	$V_{ON}$ : 2.5 V ac/dc, 70 mA max $V_{OFF}$ : 40 V ac/dc max
<b>Configuration parameters</b>	Pulse weight (from 0.01 to 9.99 kWh per pulse) Pulse duration (40 or 100 ms)
<b>Configuration mode</b>	Via keypad or UCS software

## RS485 port

<b>Protocol</b>	Modbus RTU
<b>Devices on the same bus</b>	Max 160 (1/5 unit load)
<b>Communication type</b>	Multidrop, bidirectional
<b>Connection type</b>	Detachable terminals, 2 wires, maximum distance 1000 m
<b>Configuration parameters</b>	Modbus address (from 1 to 247) Baud rate (9.6 / 19.2 / 38.4 kbps) Parity (None / Even)
<b>Configuration mode</b>	Via keypad or UCS software

## Special functions

- Display of total loads connected in relation to energy consumption and power measurements (SUM function)
- Measurements independent from direction of current (Easy connection function)
- Resetting of active energy meters of single and total loads
- Resetting of maximum values within set active and apparent power interval
- Configuration of phase order: 1-2-3-1-2-3 or 3-2-1-3-2-1
- Password protected settings menu



## Connection Diagrams

Note: for three-phase systems without neutral (3 wires) do not consider the connection to neutral **N**.

Note: fuses F of 315 mA, if required by local law.

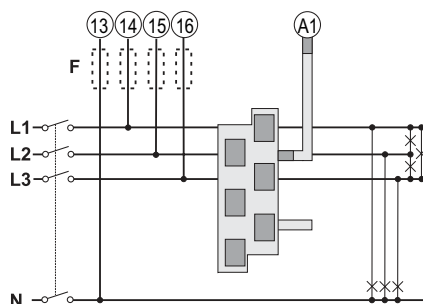

**Fig. 3** Three-phase system, one three-phase load.

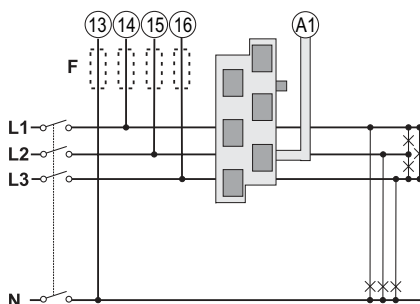

**Fig. 4** Three-phase system, one three-phase load.

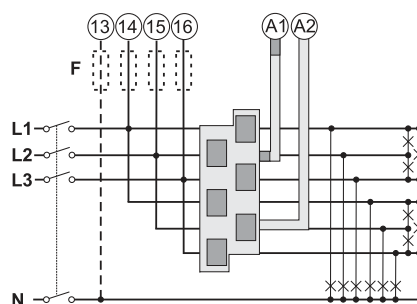

**Fig. 5** Three-phase system, two three-phase loads.

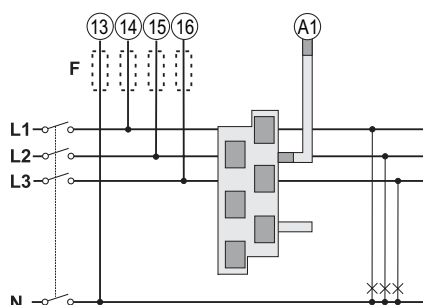

**Fig. 6** Three-phase system, three single-phase loads.

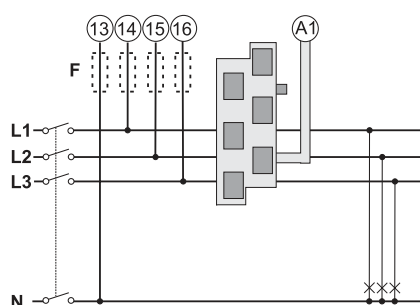

**Fig. 7** Three-phase system, three single-phase loads.

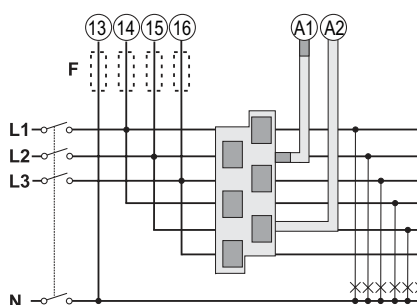

**Fig. 8** Three-phase system, six single-phase loads.

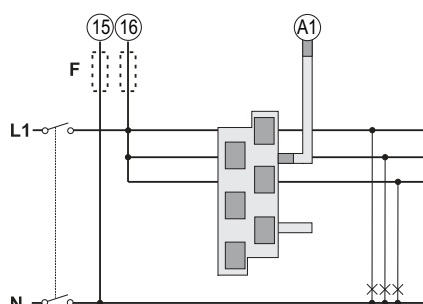

**Fig. 9** Single-phase system, three single-phase loads.

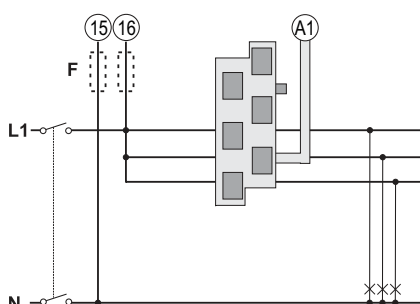

**Fig. 10** Single-phase system, three single-phase loads.

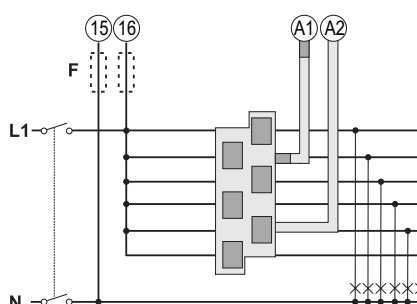

**Fig. 11** Single-phase system, six single-phase loads.

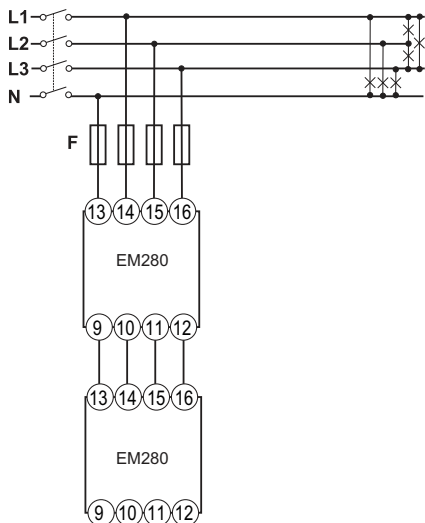

**Fig. 12** Example of connection of multiple EM280s in cascade.

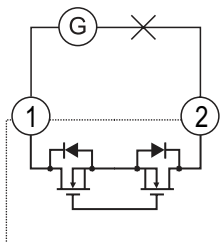

**Fig. 13** Pulse output 1.

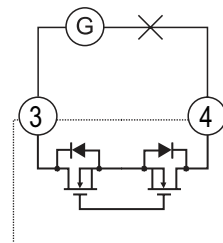

**Fig. 14** Pulse output 2.

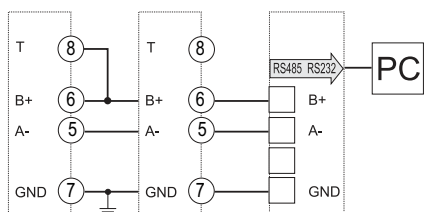

**Fig. 15** RS485 port.

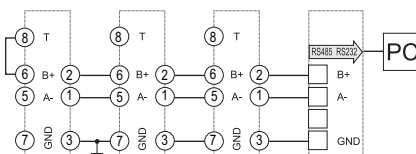

**Fig. 16** Double RS485 port for daisy chain connection.

## References

### Order code



EM280 72D MV  3X  S  (16 total characters)

Enter the code, replacing the symbol  with the selected option (e.g.: EM280 72D MV5 3X OS X).

Code	Options	Description
E	-	-
M	-	-
2	-	-
8	-	-
0	-	-
7	-	-
2	-	-
D	-	-
M	-	-
V	-	-
<input type="checkbox"/>	5	230 V L-N, 400 V L-L ac, connection via TCD06BS or TCD06BX
<input type="checkbox"/>	6	120 V L-N, 230 V L-L ac, connection via TCD06BS or TCD06BX
3	-	-
X	-	-
<input type="checkbox"/>	OS	RS485 port and double digital output
<input type="checkbox"/>	2S	Double RS485 port for daisy chain connection
<input type="checkbox"/>	X	Standard configuration
<input type="checkbox"/>	N	"Bare" configuration. With respect to the standard configuration, the bare version does NOT include: detachable terminals for voltage connections, detachable terminals for daisy chain connection via RS485 port (only for option 2S).

### Accessories: order codes

Code	Options	Description
EM270WS V 1T <input type="checkbox"/>	Replacing the symbol <input type="checkbox"/> with the cable length. Lengths available: 30, 60, 90, 150, 200 cm.	Pre-wired cables for voltage connection (one terminal block).
EM270WS V 2T <input type="checkbox"/>	Replacing the symbol <input type="checkbox"/> with the cable length. Lengths available: 30, 60, 90, 150, 200 cm.	Pre-wired cables for voltage connection (two terminal blocks).
EM270WS S 2T <input type="checkbox"/>	Replacing the symbol <input type="checkbox"/> with the cable length. Lengths available: 60, 90, 120, 180, 230 cm.	Pre-wired cables for RS485 connection (two terminal blocks).
EM270WS T V	-	20 detachable terminal blocks for voltage connections.
EM270WS T C	-	20 plastic protection covers for voltage output.
EM270WS T S	-	20 detachable terminal blocks for daisy chain connection of RS485 port.
EM200-96 ADAPTER	-	Adapter to 96 x 96 panel mounting.

### ▶ Further reading

Information	Document	Where to find it
Instruction manual	Instruction manual - EM280	<a href="http://www.productselection.net">www.productselection.net</a>

### ▶ CARLO GAVAZZI compatible components

Purpose	Component name/code key	Notes
Current measurement accessories (mandatory)	TCD06BS TCD06BX	See next chapter
Configure analyzer via desktop application	UCS configuration software	Available for free download at: <a href="http://www.productselection.net">www.productselection.net</a>
Monitor data from several analyzers	VMU-C EM	See relevant datasheet

# TCD06BS



## Main features

- 6 split core current transformers
- Primary current 32 A
- Hole diameter: 8.5 mm
- Distance between hole centers: 17.5 mm
- Connection to the EM280 with two cables with RJ-11 connectors
- Mounting on panel or DIN rail
- Mechanical lock to prevent accidental opening

## Main functions

- Conversion of current for input to the power analyzer EM280.

## Description

6-channel split core current transformer block for power analyzer EM280.

This manages primary current up to 32 A and the value is read automatically by the EM280 to eliminate the need for configuration and calibration by the user.

It is equipped with RJ-11 connectors for simple connection to the EM280.

## Structure

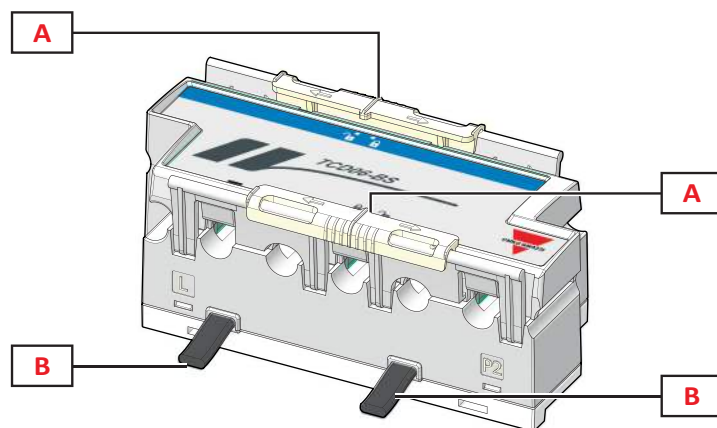

Area	Description
A	Mechanical lock to prevent accidental opening
B	Cables with RJ-11 connectors for connection to the EM280

## Features

### General

<b>Material</b>	Frianyl C3 H V0 GY7035/TA
<b>Protection degree</b>	Front: IP50
<b>Terminals</b>	RJ-11 connector
<b>Overvoltage category</b>	Cat. III
<b>Pollution degree</b>	2
<b>Insulation</b>	60s 1500 V ac (RJ connectors to housing)
<b>Mounting</b>	Panel mounting, by means of four removable hooks DIN rail
<b>Weight</b>	350 g (packaging included)

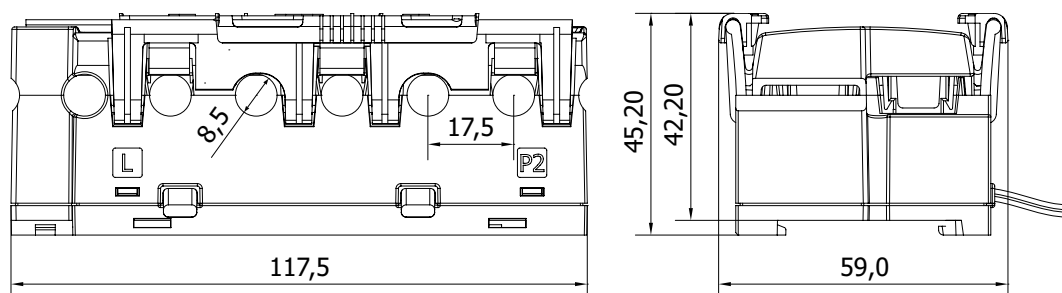

### Environmental specifications

<b>Operating temperature</b>	From -25 to +55 °C/from -13 to +131 °F
<b>Storage temperature</b>	From -30 to +70 °C/from -22 to +158 °F

### Electrical specifications

<b>Primary current (In)</b>	32 A
<b>Maximum current (continuous)</b>	1.2 In
<b>Maximum system voltage</b>	0.72 kV ac
<b>Frequency</b>	From 45 to 65 Hz
<b>Accuracy</b>	0.5%
<b>Phase error</b>	<4°



## Connection Diagrams

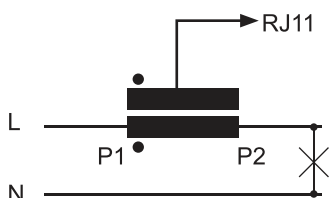

Fig. 17 Current connection

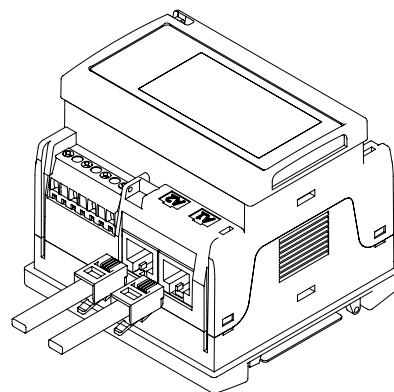

Fig. 18 RJ11 connections

## References

### Order code



TCD06BS 32  CM X

Enter the code, replacing the symbol  with the length of the cable with RJ11 connectors (2 or 3 digits). Lengths available: 80, 150, 200 cm.

### Further reading

Information	Document	Where to find it
Instruction manual	Instruction manual - TCD06BS	<a href="http://www.productselection.net">www.productselection.net</a>

### CARLO GAVAZZI compatible components

Purpose	Component name/code key	Notes
Measure and display consumption of connected loads	EM280	See relevant datasheet

# TCD06BX



## ▶ Main features

- 6 solid core current transformers
- Primary current 32 A
- Hole diameter: 8.5 mm
- Distance between hole centers: 17.5 mm
- Connection to the EM280 with two cables with RJ-11 connectors
- Mounting on panel or DIN rail

## ▶ Main functions

- Conversion of current for input to the power analyzer EM280.

## ▶ Description

6-channel solid core current transformer block for power analyzer EM280.

This manages primary current up to 32 A and the value is read automatically by the EM280 to eliminate the need for configuration and calibration by the user.

It is equipped with RJ-11 connectors for simple connection to the EM280.

## ▶ Structure

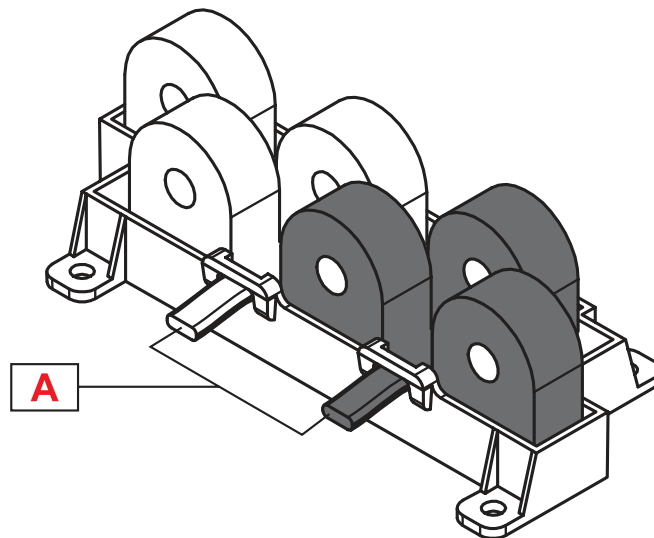

Area	Description
A	Cables with RJ-11 connectors for connection to the EM280



## Features

### General

<b>Material</b>	Frianyl C3 H V0 GY7035/TA
<b>Protection degree</b>	Front: IP50
<b>Terminals</b>	RJ-11 connector
<b>Overvoltage category</b>	Cat. III
<b>Pollution degree</b>	2
<b>Insulation</b>	60s 1500 V ac (RJ connectors to housing)
<b>Mounting</b>	Panel mounting, by means of four removable hooks
<b>Weight</b>	350 g (packaging included)

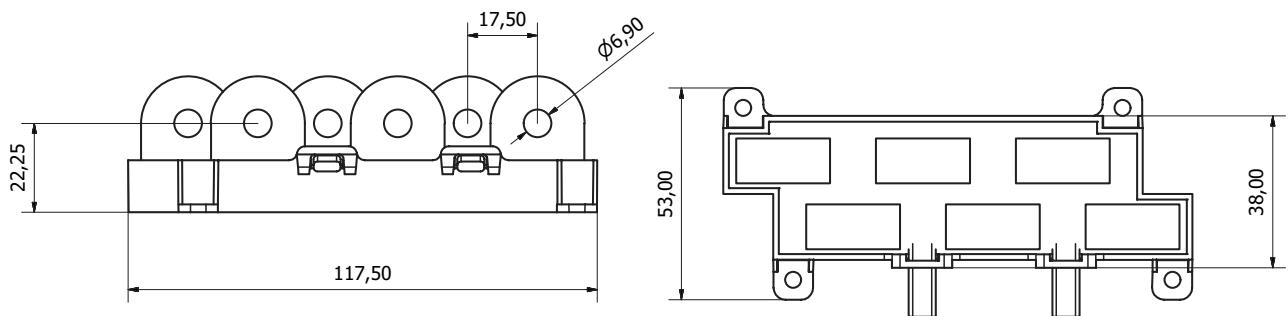

### Environmental specifications

<b>Operating temperature</b>	From -25 to +55 °C/from -13 to +131 °F
<b>Storage temperature</b>	From -30 to +70 °C/from -22 to +158 °F

### Electrical specifications

<b>Primary current (I<sub>n</sub>)</b>	32 A
<b>Maximum current (continuous)</b>	1.2 I <sub>n</sub>
<b>Maximum system voltage</b>	0.72 kV ac
<b>Frequency</b>	From 45 to 65 Hz
<b>Accuracy</b>	0.5%



## Connection Diagrams

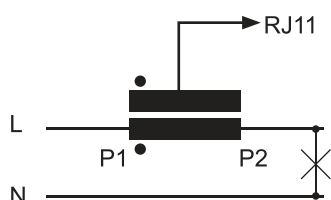

Fig. 19 Current connection

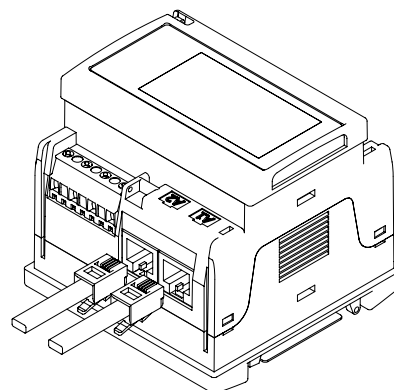

Fig. 20 RJ11 connections

## References

### Order code



TCD06BX 32  CM X

Enter the code, replacing the symbol  with the length of the cable with RJ11 connectors (2 or 3 digits). Lengths available: 80, 150, 200 cm.

### Further reading

Information	Document	Where to find it
Instruction manual	Instruction manual - TCD06BX	<a href="http://www.productselection.net">www.productselection.net</a>

### CARLO GAVAZZI compatible components

Purpose	Component name/code key	Notes
Measure and display consumption of connected loads	EM280	See relevant datasheet

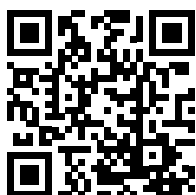

COPYRIGHT ©2017  
Content subject to change. Download the PDF: [www.productselection.net](http://www.productselection.net)