

## General Description

The 8V41N010 is a PLL-based clock generator specifically designed for Cavium Networks Octeon II processors. This high performance device is optimized to generate the processor core reference clock, the PCI-Express, sRIO, XAU1, SerDes reference clocks and the clocks for both the Gigabit Ethernet MAC and PHY. The output frequencies are generated from a 25MHz external input source or an external 25MHz parallel resonant crystal. The industrial temperature range of the 8V41N010 supports telecommunication, networking, and storage requirements.

## Features

- Eight selectable 100MHz and 156.25MHz clocks for PCI Express, sRIO and GbE, HCSL interface levels
- One single-ended QF LVCMOS/LVTTL clock output at 50MHz
- Selectable external crystal or differential (single-ended) input source
- Crystal oscillator interface designed for 25MHz, parallel resonant crystal
- Differential CLK, nCLK input pair that can accept: LVPECL, LVDS, LVHSTL, HCSL input levels
- Internal resistor bias on nCLK pin allows the user to drive CLK input with external single-ended (LVCMOS/ LVTTL) input levels
- Full 3.3V supply mode
- -40°C to 85°C ambient operating temperature
- Lead-free (RoHS 6) packaging

## Pin Assignment

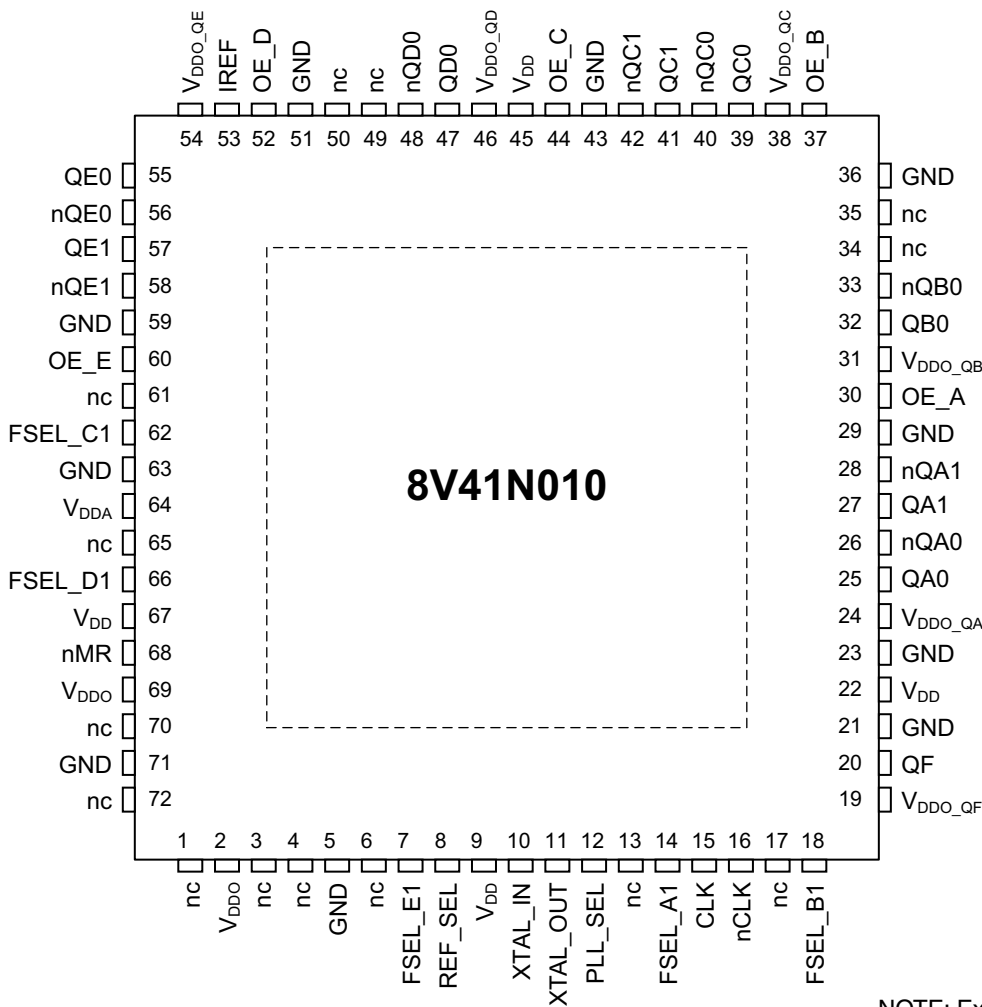

72-pin, 10mm x 10mm VFQFN Package

NOTE: Exposed pad must always be connected to GND.  
NOTE: Pin 1 is located at bottom left corner as shown.

# Block Diagram

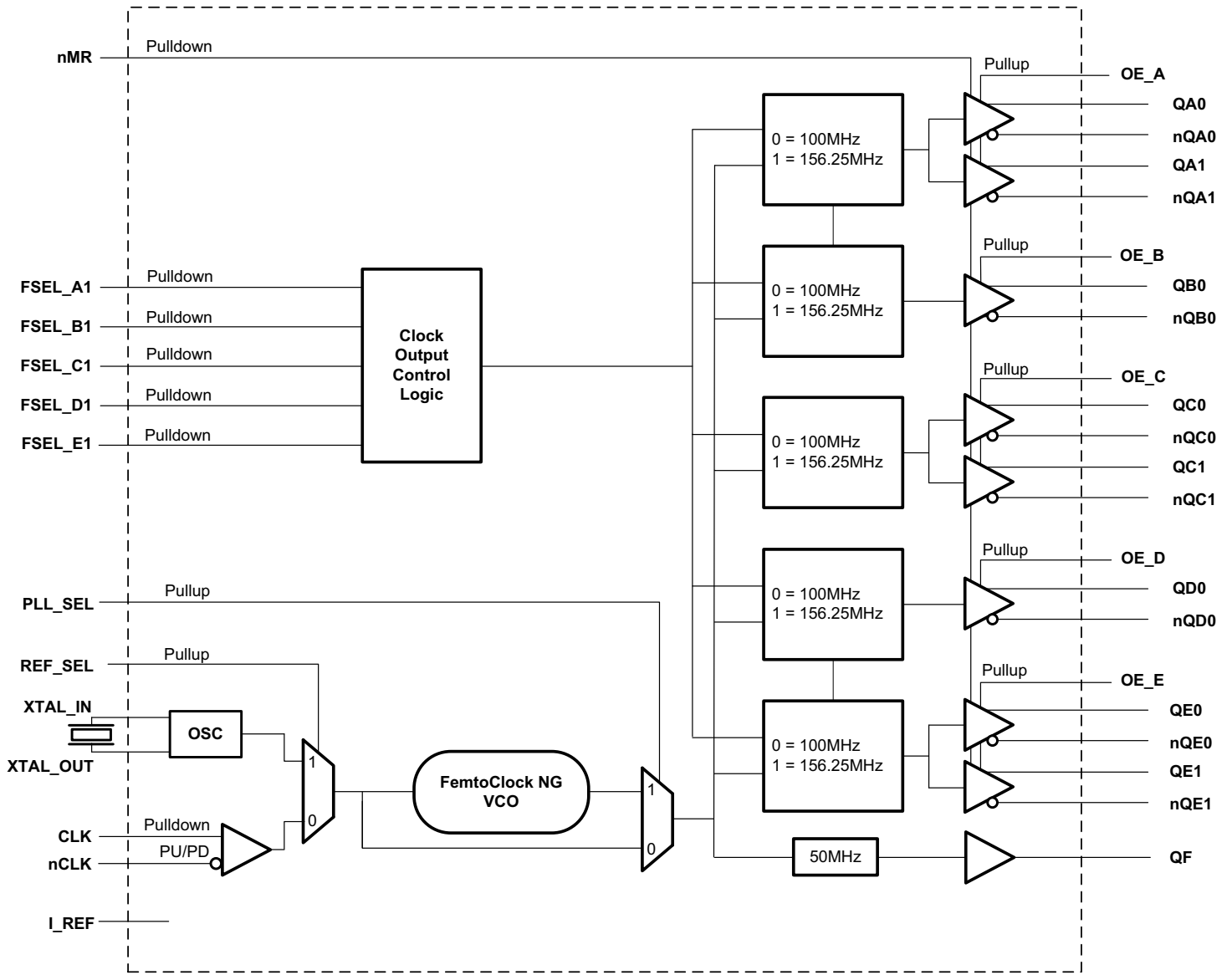

## Pin Descriptions and Characteristics

Table 1. Pin Descriptions

Number	Name	Type		Description
1	nc	Unused		No internal connection.
2	V <sub>DDO</sub>	Power		Output supply.
3	nc	Unused		No internal connection.
4	nc	Unused		No internal connection.
5	GND	Power		Power supply ground.
6	nc	Unused		No internal connection.
7	FSEL_E1	Input	Pulldown	Selects the QEx, nQEx output frequency. LVCMOS/LVTTL interface levels. 0 = 100MHz (default) 1 = 156.25MHz
8	REF_SEL	Input	Pullup	Input source control pin. LVCMOS/LVTTL interface levels. 0 = CLK, nCLK 1 = XTAL (default)
9	V <sub>DD</sub>	Power		Core supply.
10	XTAL_IN	Crystal Input		Parallel resonant crystal input.
11	XTAL_OUT	Crystal Output		Parallel resonant crystal output.
12	PLL_SEL	Input	Pullup	PLL bypass control pin. LVCMOS/LVTTL interface levels. 0 = Bypass mode 1 = PLL mode (default)
13	nc	Unused		No internal connection.
14	FSEL_A1	Input	Pulldown	Selects the QAx, nQAx output frequency. LVCMOS/LVTTL interface levels. 0 = 100MHz (default) 1 = 156.25MHz
15	CLK	Input	Pulldown	Non-inverting differential clock input.
16	nCLK	Input	Pullup/ Pulldown	Inverting differential clock input. Internal resistor bias to V <sub>DD</sub> /2.
17	nc	Unused		No internal connection.
18	FSEL_B1	Input	Pulldown	Selects the QBx, nQBx output frequency. LVCMOS/LVTTL interface levels. 0 = 100MHz (default) 1 = 156.25MHz
19	V <sub>DDO_QF</sub>	Power		QF output supply (LVCMOS/LVTTL).
20	QF	Output		Single-ended output. 3.3V LVCMOS/LVTTL interface levels.
21	GND	Power		Power supply ground.
22	V <sub>DD</sub>	Power		Core supply.
23	GND	Power		Power supply ground.
24	V <sub>DDO_QA</sub>	Power		Bank A (HCSL) output supply.
25	QA0	Output		Bank A differential output pair. HCSL interface levels.
26	nQA0	Output		Bank A differential output pair. HCSL interface levels.
27	QA1	Output		Bank A differential output pair. HCSL interface levels.
28	nQA1	Output		Bank A differential output pair. HCSL interface levels.
29	GND	Power		Power supply ground.
30	OE_A	Input	Pullup	Active HIGH output enable for Bank A outputs. LVCMOS/LVTTL interface levels. 0 = Bank A outputs disabled/high impedance 1 = Bank A outputs enabled (default)

**Table 1. Pin Descriptions, Continued**

Number	Name	Type		Description
31	V <sub>DDO_QB</sub>	Power		Bank B (HCSL) output supply.
32	QB0	Output		Bank B differential output pair. HCSL interface levels.
33	nQB0	Output		Bank B differential output pair. HCSL interface levels.
34	nc	Unused		No internal connection.
35	nc	Unused		No internal connection.
36	GND	Power		Power supply ground.
37	OE_B	Input	Pullup	Active HIGH output enable for Bank B outputs. LVCMOS/LVTTL interface levels. 0 = Bank B outputs disabled/high impedance
38	V <sub>DDO_QC</sub>	Power		Bank C (HCSL) output supply.
39	QC0	Output		Bank C differential output pair. HCSL interface levels.
40	nQC0	Output		Bank C differential output pair. HCSL interface levels.
41	QC1	Output		Bank C differential output pair. HCSL interface levels.
42	nQC1	Output		Bank C differential output pair. HCSL interface levels.
43	GND	Power		Power supply ground.
44	OE_C	Input	Pullup	Active HIGH output enable for Bank C outputs. LVCMOS/LVTTL interface levels. 0 = Bank C outputs disabled/high impedance 1 = Bank C outputs enabled (default)
45	V <sub>DD</sub>	Power		Core supply.
46	V <sub>DDO_QD</sub>	Power		Bank D (HCSL) output supply.
47	QD0	Output		Bank D differential output pair. HCSL interface levels.
48	nQD0	Output		Bank D differential output pair. HCSL interface levels.
49	nc	Unused		No internal connection.
50	nc	Unused		No internal connection.
51	GND	Power		Power supply ground.
52	OE_D	Input	Pullup	Active HIGH output enable for Bank D outputs. LVCMOS/LVTTL interface levels. 0 = Bank D outputs disabled/high impedance
53	IREF	Input		External fixed precision resistor (475Ω) from this pin to ground provides a reference current used for differential current-mode.
54	V <sub>DDO_QE</sub>	Power		Bank E (HCSL) output supply.
55	QE0	Output		Bank E differential output pair. HCSL interface levels.
56	nQE0	Output		Bank E differential output pair. HCSL interface levels.
57	QE1	Output		Bank E differential output pair. HCSL interface levels.
58	nQE1	Output		Bank E differential output pair. HCSL interface levels.
59	GND	Power		Power supply ground.
60	OE_E	Input	Pullup	Active HIGH output enable for Bank E outputs. LVCMOS/LVTTL interface levels. 0 = Bank E outputs disabled/high impedance 1 = Bank E outputs enabled (default)
61	nc	Unused		No internal connection.
62	FSEL_C1	Input	Pulldown	Selects the QCx, nQCx output frequency. LVCMOS/LVTTL interface levels. 0 = 100MHz (default) 1 = 156.25MHz
63	GND	Power		Power supply ground.
64	V <sub>DDA</sub>	Power		Analog supply.

**Table 1. Pin Descriptions**

Number	Name	Type		Description
65	nc	Unused		No internal connection.
66	FSEL_D1	Input	Pulldown	Selects the QDx, nQDx output frequency. LVCMOS/LVTTL interface levels. 0 = 100MHz (default) 1 = 156.25MHz
67	V <sub>DD</sub>	Power		Core supply.
68	nMR	Input	Pulldown	Active LOW Master Reset. LVCMOS/LVTTL interface levels. 0 = Reset. The internal dividers are reset causing the true outputs Qx to go low and the inverted outputs nQx to go high. (default) 1 = Active. The internal dividers and the outputs are active.
69	V <sub>DDO</sub>	Power		Output supply.
70	nc	Unused		No internal connection.
71	GND	Power		Power supply ground.
72	nc	Unused		No internal connection.
ePAD	GND_EP	Power		Exposed pad of package. Connect to GND.

NOTE: *Pullup* and *Pulldown* refer to internal input resistors. See Table 2, *Pin Characteristics*, for typical values.

**Table 2. Pin Characteristics**

Symbol	Parameter		Test Conditions	Minimum	Typical	Maximum	Units
C <sub>IN</sub>	Input Capacitance	CLK, nCLK			2.5		pF
		Control Pins			6		pF
R <sub>PULLUP</sub>	Input Pullup Resistor				50		kΩ
R <sub>PULLDOWN</sub>	Input Pulldown Resistor				50		kΩ
R <sub>OUT</sub>	Output Impedance	QF	V <sub>DDO_QF</sub> = 3.465V		15		Ω

## Function Tables

**Table 3A. FSEL\_X Control Input Function Table**

Input	Output Frequency
<b>FSEL_X1</b>	<b>Q[Ax:Ex], nQ[Ax:Ex]</b>
0 (default)	100MHz
1	156.25MHz

NOTE: FSEL\_X denotes FSEL\_A, \_B, \_C, \_D, \_E.

NOTE: Any two outputs operated at the same frequency will be synchronous.

**Table 3B. PLL\_SEL Control Input Function Table**

Input	Operation
<b>PLL_SEL</b>	
0	PLL Bypass
1 (default)	PLL Mode

**Table 3C. REF\_SEL Control Input Function Table**

Input	Clock Source
<b>REF_SEL</b>	
0	CLK, nCLK
1 (default)	XTAL_IN, XTAL_OUT

**Table 3D. OE\_[A:E] Control Input Function Table**

Input	Outputs
<b>OE_[A:E]</b>	<b>Q[Ax:Ex], nQ[Ax:Ex]</b>
0	High-Impedance
1 (default)	Enabled

## Absolute Maximum Ratings

NOTE: Stresses beyond those listed under *Absolute Maximum Ratings* may cause permanent damage to the device. These ratings are stress specifications only. Functional operation of product at these conditions or any conditions beyond those listed in the *DC Characteristics* or *AC Characteristics* is not implied. Exposure to absolute maximum rating conditions for extended periods may affect product reliability.

Item	Rating
Supply Voltage, $V_{DD}$	3.6V
Inputs, $V_I$ XTAL_IN Other Inputs	0V to 2V -0.5V to $V_{DD} + 0.5V$
Outputs, $V_O$	-0.5V to $V_{DDO\_QX}^1 + 0.5V$
Maximum Junction Temperature, $T_{JMAX}$	125°C
Storage Temperature, $T_{STG}$	-65°C to 150°C

NOTE 1.  $V_{DDO\_QX}$  denotes:  $V_{DDO\_QA}$ ,  $V_{DDO\_QB}$ ,  $V_{DDO\_QC}$ ,  $V_{DDO\_QD}$ ,  $V_{DDO\_QE}$ ,  $V_{DDO\_QF}$ .

## DC Electrical Characteristics

**Table 4A. Power Supply DC Characteristics,  $V_{DD} = 3.3V \pm 5\%$ ,  $V_{DDO\_Q[A:E]} = V_{DDO\_QF} = 3.3V \pm 5\%$ ,  $T_A = -40^\circ C$  to  $85^\circ C$**

Symbol	Parameter	Test Conditions	Minimum	Typical	Maximum	Units
$V_{DD}$	Core Supply Voltage		3.135	3.3	3.465	V
$V_{DDA}$	Analog Supply Voltage		3.135	3.3	3.465	V
$V_{DDO\_QX}^1$	Output Supply Voltage		3.135	3.3	3.465	V
$I_{DD}$	Power Supply Current			193	235	mA
$I_{DDA}$	Analog Supply Current			36	47	mA
$I_{DDO\_QX}^2$	Output Supply Current	No Load		24	30	mA

NOTE 1.  $V_{DDO\_QX}$  denotes  $V_{DDO\_Q[A:E]}$ ,  $V_{DDO\_QF}$ .

NOTE 2.  $I_{DDO\_QX}$  denotes  $I_{DDO\_Q[A:E]} + I_{DDO\_QF}$ .

**Table 4B. LVCMOS/LVTTL DC Characteristics,  $V_{DD} = V_{DDO\_Q[A:E]} = V_{DDO\_QF} = 3.3V \pm 5\%$ ,  $T_A = -40^\circ C$  to  $85^\circ C$** 

Symbol	Parameter		Test Conditions	Minimum	Typical	Maximum	Units
$V_{IH}$	Input High Voltage			2.2		$V_{DD} + 0.3$	V
$V_{IL}$	Input Low Voltage			-0.3		0.8	V
$I_{IH}$	Input High Current	nMR, FSEL_A1, FSEL_B1, FSEL_C1, FSEL_D1, FSEL_E1	$V_{DD} = V_{IN} = 3.465V$			150	$\mu A$
		REF_SEL, PLL_SEL, OE_A, OE_B, OE_C, OE_D, OE_E	$V_{DD} = V_{IN} = 3.465V$			10	$\mu A$
$I_{IL}$	Input Low Current	nMR, FSEL_A1, FSEL_B1, FSEL_C1, FSEL_D1, FSEL_E1	$V_{DD} = 3.465V, V_{IN} = 0V$	-10			$\mu A$
		REF_SEL, PLL_SEL, OE_A, OE_B, OE_C, OE_D, OE_E	$V_{DD} = 3.465V, V_{IN} = 0V$	-150			$\mu A$
$V_{OH}$	Output High Voltage		$V_{DDO\_QF} = 3.465V$	2.6			V
$V_{OL}$	Output Low Voltage		$V_{DDO\_QF} = 3.465V$			0.6	V

**Table 4C. Differential DC Characteristics,  $V_{DD} = 3.3V \pm 5\%$ ,  $T_A = -40^\circ C$  to  $85^\circ C$** 

Symbol	Parameter		Test Conditions	Minimum	Typical	Maximum	Units
$I_{IH}$	Input High Current	CLK, nCLK	$V_{DD} = V_{IN} = 3.465V$			150	$\mu A$
$I_{IL}$	Input Low Current	CLK	$V_{DD} = 3.465V, V_{IN} = 0V$	-5			$\mu A$
		nCLK	$V_{DD} = 3.465V, V_{IN} = 0V$	-150			$\mu A$
$V_{PP}$	Peak-to-Peak Input Voltage <sup>1</sup>			0.15		1.3	V
$V_{CMR}$	Common Mode Input Voltage <sup>12</sup>			0.5		$V_{DD} - 0.85$	V

NOTE 1.  $V_{IL}$  should not be less than -0.3V.

NOTE 2. Common mode voltage is defined as  $V_{IH}$ .

**Table 5. Table 5. Crystal Characteristics**

Parameter	Test Conditions	Minimum	Typical	Maximum	Units
Mode of Oscillation			Fundamental		
Frequency			25		MHz
Equivalent Series Resistance (ESR)				50	$\Omega$
Load Capacitance (CL)			12		pF
Shunt Capacitance				7	pF

**Table 6. Input Frequency Characteristics,  $V_{DD} = V_{DDO\_Q[A:E]} = V_{DDO\_QF} = 3.3V \pm 5\%$ ,  $T_A = -40^\circ C$  to  $85^\circ C$** 

Symbol	Parameter		Test Conditions	Minimum	Typical	Maximum	Units
$F_{IN}$	Input Frequency	CLK, nCLK			25		MHz
		XTAL_IN, XTAL_OUT			25		MHz

## AC Electrical Characteristics

**Table 7A. PCI Express Jitter Specifications,  $V_{DD} = V_{DDO\_Q[A:E]} = 3.3V \pm 5\%$ ,  $T_A = -40^{\circ}C$  to  $85^{\circ}C$ <sup>1 2</sup>**

Symbol	Parameter	Test Conditions	Minimum	Typical	Maximum	PCIe Industry Specification	Units
$t_j$ (PCIe Gen 1)	Phase Jitter Peak-to-Peak <sup>3 4</sup>	$f = 100MHz$ , 25MHz Crystal Input Evaluation Band: 0Hz - Nyquist (clock frequency/2)		6.97	11.18	86	ps
$t_{REFCLK\_HF\_RMS}$ (PCIe Gen 2)	Phase Jitter RMS <sup>3 5</sup>	$f = 100MHz$ , 25MHz Crystal Input High Band: 1.5MHz - Nyquist (clock frequency/2)		0.70	1.84	3.10	ps
$t_{REFCLK\_LF\_RMS}$ (PCIe Gen 2)	Phase Jitter RMS <sup>3 4</sup>	$f = 100MHz$ , 25MHz Crystal Input Low Band: 10kHz - 1.5MHz		0.03	0.07	3.0	ps
$t_{REFCLK\_RMS}$ (PCIe Gen 3)	Phase Jitter RMS <sup>3 6</sup>	$f = 100MHz$ , 25MHz Crystal Input Evaluation Band: 0Hz - Nyquist (clock frequency/2)		0.16	0.49	0.8	ps

NOTE 1. Electrical parameters are guaranteed over the specified ambient operating temperature range, which is established when the device is mounted in a test socket with maintained transverse airflow greater than 500 lpm. The device will meet specifications after thermal equilibrium has been reached under these conditions. For additional information, refer to the *PCI Express Application Note section* in the datasheet.

NOTE 2. Design Target Specifications.

NOTE 3. Peak-to-Peak jitter after applying system transfer function for the Common Clock Architecture. Maximum limit for PCI Express Gen 1 is 86ps peak-to-peak for a sample size of  $10^6$  clock periods.

NOTE 4. This parameter is guaranteed by characterization. Not tested in production.

NOTE 5. RMS jitter after applying the two evaluation bands to the two transfer functions defined in the Common Clock Architecture and reporting the worst case results for each evaluation band. Maximum limit for PCI Express Generation 2 is 3.1ps RMS for  $t_{REFCLK\_HF\_RMS}$  (High Band) and 3.0ps RMS for  $t_{REFCLK\_LF\_RMS}$  (Low Band).

NOTE 6. RMS jitter after applying system transfer function for the common clock architecture. This specification is based on the *PCI Express Base Specification Revision 0.7, October 2009* and is subject to change pending the final release version of the specification.



**Table 7B. HCSL AC Characteristics,  $V_{DD} = V_{DDO\_Q[A:E]} = V_{DDO\_QF} = 3.3V \pm 5\%$ ,  $T_A = -40^\circ C$  to  $85^\circ C$ <sup>1 2 3</sup>**

Symbol	Parameter	Test Conditions	Minimum	Typical	Maximum	Units
f <sub>OUT</sub>	Output Frequency	Q[A:E], nQ[A:E]	FSEL_X1 = 0	100		MHz
			FSEL_X1 = 1	156.25		MHz
V <sub>RB</sub>	Ring-Back Voltage Margin <sup>4 5</sup>	Q[A:E], nQ[A:E]	-100		100	mV
t <sub>STABLE</sub>	Time before V <sub>RB</sub> is allowed <sup>1 2</sup>	Q[A:E], nQ[A:E]	500			ps
V <sub>MAX</sub>	Absolute Max Output Voltage <sup>6 7</sup>	Q[A:E], nQ[A:E]			1150	mV
V <sub>MIN</sub>	Absolute Min Output Voltage <sup>3 8</sup>	Q[A:E], nQ[A:E]	-300			mV
V <sub>CROSS</sub>	Absolute Crossing Voltage <sup>3 9 10</sup>	Q[A:E], nQ[A:E]	175		550	mV
ΔV <sub>CROSS</sub>	Total Variation of V <sub>CROSS</sub> over All Edges <sup>3 6 11</sup>	Q[A:E], nQ[A:E]			140	mV
t <sub>SLEW+</sub>	Rising Edge Rate <sup>1 12</sup>	Q[A:E], nQ[A:E]	0.6		4.0	V/ns
t <sub>SLEW-</sub>	Falling Edge Rate <sup>1 9</sup>	Q[A:E], nQ[A:E]	0.6		4.0	V/ns
odc	Output Duty Cycle	Q[A:E], nQ[A:E]	48	50	52	%
tjit(∅)	RMS Phase Jitter, (Random) <sup>13</sup>	Q[A:E], nQ[A:E]	100MHz, Integration Range: (12kHz to 20MHz)	0.32	0.45	ps
			156.25MHz, Integration Range: (12kHz to 20MHz)	0.30	0.45	ps
tjit(RMS)	Jitter, RMS	Q[A:E], nQ[A:E] = 100MHz or 156.25MHz, 25MHz XTAL, PLL Mode <sup>14</sup>		2.6		ps
tjit(p-p)	Jitter, (peak-to-peak) <sup>15</sup>			19		ps

NOTE 1. Electrical parameters are guaranteed over the specified ambient operating temperature range, which is established when the device is mounted in a test socket with maintained transverse airflow greater than 500 lpm. The device will meet specifications after thermal equilibrium has been reached under these conditions.

NOTE 2. All parameters measured at f<sub>OUT</sub> and in PLL mode unless noted otherwise.

NOTE 3. Refer to applications section for information on peak-to-peak jitter calculations.

NOTE 4. Measurement taken from differential waveform.

NOTE 5. t<sub>STABLE</sub> is the time the differential clock must maintain a minimum ±150mV differential voltage after rising/falling edges before it is allowed to drop back into the V<sub>RB</sub> ±100mV range. See Parameter Measurement Information Section.

NOTE 6. Measurement taken from single-ended waveform.

NOTE 7. Defined as the maximum instantaneous voltage including overshoot.

NOTE 8. Defined as the minimum instantaneous voltage including undershoot.

NOTE 9. Measured at the crossing point where the instantaneous voltage value of the rising edge of Q[Ax:Ex] equals the falling edge of nQ[Ax:Ex]

NOTE 10. Refers to the total variation from the lowest crossing point to the highest, regardless of which edge is crossing. Refers to all crossing points for this measurement.

NOTE 11. Defined as the total variation of all crossing voltages of rising Q[Ax:Ex] and falling nQ[Ax:Ex]. This is the maximum allowed variance in V<sub>cross</sub> for any particular system.

NOTE 12. Measured from -150mV to +150mV on the differential waveform (derived from Q[Ax:Ex] minus nQ[Ax:Ex]). The signal must be monotonic through the measurement region for rise and fall time. The 300mV measurement window is centered on the differential zero crossing

NOTE 13. Measurements taken with 25MHz XTAL as input source and spur off

NOTE 14. All differential outputs are running at the same frequency.

NOTE 15. tjit(p-p) is a calculated value given RMS multiplier = 7.438. For detailed description of algorithm, please refer to [Section, “Applications Information”, Peak-to-Peak Jitter Calculations](#).

**Table 7C. LVCMOS AC Characteristics,  $V_{DD} = V_{DDO\_Q[A:E]} = V_{DDO\_QF} = 3.3V \pm 5\%$ ,  $T_A = -40^{\circ}C$  to  $85^{\circ}C$ <sup>1</sup>**

Symbol	Parameter	Test Conditions	Minimum	Typical	Maximum	Units	
$f_{OUT}$	Output Frequency	QF		50		MHz	
tr/tf	Output Rise/Fall Time	QF	20% to 80%	180	700	ps	
odc	Output Duty Cycle	QF		47	50	53	%
tjit( $\emptyset$ )	RMS Phase Jitter, (Random) <sup>2</sup>	QF	50MHz, Integration Range: (12kHz to 20MHz)	0.35	0.45	ps	
tjit(R <sub>J</sub> )	Random Jitter, RMS <sup>3</sup>	QF	Q[A:E], nQ[A:E] = 156.25MHz, 25MHz XTAL, PLL Mode	2		ps	
tjit(D <sub>J</sub> )	Deterministic Jitter, Pk-to-Pk <sup>4</sup>	QF	Q[A:E], nQ[A:E] = 156.25MHz, 25MHz XTAL, PLL Mode	3		ps	

NOTE 1. Electrical parameters are guaranteed over the specified ambient operating temperature range, which is established when the device is mounted in a test socket with maintained transverse airflow greater than 500 lpm. The device will meet specifications after thermal equilibrium has been reached under these conditions.

NOTE 2. Measurements taken with 25MHz XTAL as input source and spur off.

NOTE 3. Measurements taken with Wavecrest SIA-3000 Analyzer.

## Typical Phase Noise at 156.25MHz

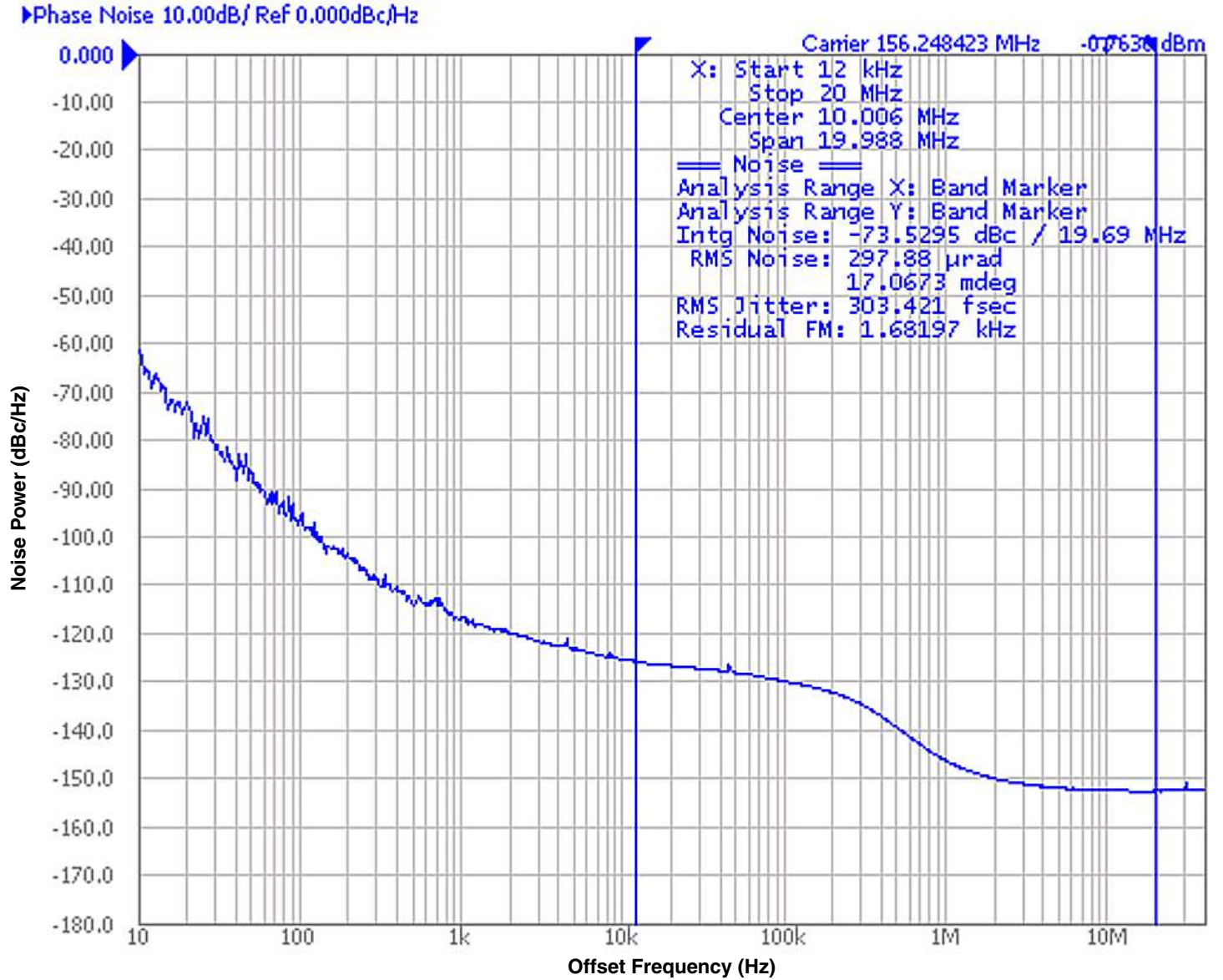

## Applications Information

### Peak-to-Peak Jitter Calculations

A standard deviation of a statistical population or data set is the square root of its variance. A standard deviation is used to calculate the probability of an anomaly or to predict a failure. Many times, the term "root mean square" (RMS) is used synonymously for standard deviation. This is accurate when referring to the square root of the mean squared deviation of a signal from a given baseline and when the data set contains a Gaussian distribution with no deterministic components. A low standard deviation indicates that the data set is close to the mean with little variation. A large standard deviation indicates that the data set is spread out and has a large variation from the mean.

A standard deviation is required when calculating peak-to-peak jitter. Since true peak-to-peak jitter is random and unbounded, it is important to always associate a bit error ratio (BER) when specifying a peak-to-peak jitter limit. Without it, the specification does not have a boundary and will continue get larger with sample size. Given that a BER is application specific, many frequency timing devices specify jitter as an RMS. This allows the peak-to-peak jitter to be calculated for the specific application and BER requirement. Because a standard deviation is the variation from the *mean* of the data set, it is important to always calculate the peak-to-peak jitter using the typical RMS value.

Table 8 shows the BER with its appropriate RMS Multiplier. There are two columns for the RMS multiplier, one should be used if your signal is data and the other should be used if the signal is a repetitive clock signal. The difference between the two is the data transition density (DTD). The DTD is the number of rising or falling transitions divided by the total number of bits. For a clock signal, they are equal, hence the DTD is 1. For Data, on average, most common encoding standards have a 0.5 DTD.

**Table 8. BER Table**

BER	RMS Multiplier Data, "DTD = 0.5"	RMS Multiplier Clock, "DTD = 1"
10 <sup>-3</sup>	6.180	6.582
10 <sup>-4</sup>	7.438	7.782
10 <sup>-5</sup>	8.530	8.834
10 <sup>-6</sup>	9.507	9.784
10 <sup>-7</sup>	10.399	10.654
10 <sup>-8</sup>	11.224	11.462
10 <sup>-9</sup>	11.996	12.218
10 <sup>-10</sup>	12.723	12.934
10 <sup>-11</sup>	13.412	13.614
10 <sup>-12</sup>	14.069	14.260
10 <sup>-13</sup>	14.698	14.882
10 <sup>-14</sup>	15.301	15.478
10 <sup>-15</sup>	15.883	16.028

Once the BER is chosen, there are two circumstances to consider. Is the data set purely Gaussian or does it contains any deterministic component? If it is Gaussian, then the peak to peak jitter can be calculated by simply multiplying the RMS multiplier with the typical RMS specification. For example, if a 10<sup>-12</sup> BER is required for a clock signal, multiply 14.260 times the typical jitter specification.

$$\text{Jitter (peak-to-peak)} = \text{RMS Multiplier} * \text{RMS (typical)}$$

If the datasheet contains deterministic components, then the random jitter ( $R_J$ ) and deterministic jitter ( $D_J$ ) must be separated and analyzed separately.  $R_J$ , also known as Gaussian jitter, is not bounded and the peak-to-peak will continue to get larger as the sample size increases. Alternatively, peak-to-peak value of  $D_J$  is bounded and can easily be observed and predicted. Therefore, the peak to peak jitter for the random component must be added to the deterministic component. This is called total jitter ( $T_J$ ).

$$\text{Total Jitter (peak-to-peak)} = [\text{RMS Multiplier} * \text{Random Jitter (R}_J\text{)}] + \text{Deterministic Jitter (D}_J\text{)}$$

The *total jitter equation* is not specific to one type of jitter classification. It can be used to calculate BER on various types of RMS jitter. It is important that the user understands their jitter requirement to ensure they are calculating the correct BER for their jitter requirement.

NOTE: Use  $R_J$  and  $D_J$  values from AC Characteristics Tables 7B and 7C to calculate  $T_J$ .

## Wiring the Differential Input to Accept Single-Ended Levels

Figure 1 shows how a differential input can be wired to accept single ended levels. The reference voltage  $V_1 = V_{DD}/2$  is generated by the bias resistors R1 and R2. The bypass capacitor (C1) is used to help filter noise on the DC bias. This bias circuit should be located as close to the input pin as possible. The ratio of R1 and R2 might need to be adjusted to position the  $V_1$  in the center of the input voltage swing. For example, if the input clock swing is 2.5V and  $V_{DD} = 3.3V$ , R1 and R2 value should be adjusted to set  $V_1$  at 1.25V. The values below are for when both the single ended swing and  $V_{DD}$  are at the same voltage. This configuration requires that the sum of the output impedance of the driver ( $R_o$ ) and the series resistance ( $R_s$ ) equals the transmission line impedance. In addition, matched termination at the input will attenuate the signal in half. This can be done in one of two ways. First, R3 and R4 in parallel should equal the transmission line

impedance. For most 50Ω applications, R3 and R4 can be 100Ω. The values of the resistors can be increased to reduce the loading for slower and weaker LVCMOS driver. When using single-ended signaling, the noise rejection benefits of differential signaling are reduced. Even though the differential input can handle full rail LVCMOS signaling, it is recommended that the amplitude be reduced. The datasheet specifies a lower differential amplitude, however this only applies to differential signals. For single-ended applications, the swing can be larger, however  $V_{IL}$  cannot be less than  $-0.3V$  and  $V_{IH}$  cannot be more than  $V_{DD} + 0.3V$ . Though some of the recommended components might not be used, the pads should be placed in the layout. They can be utilized for debugging purposes. The datasheet specifications are characterized and guaranteed by using a differential signal.

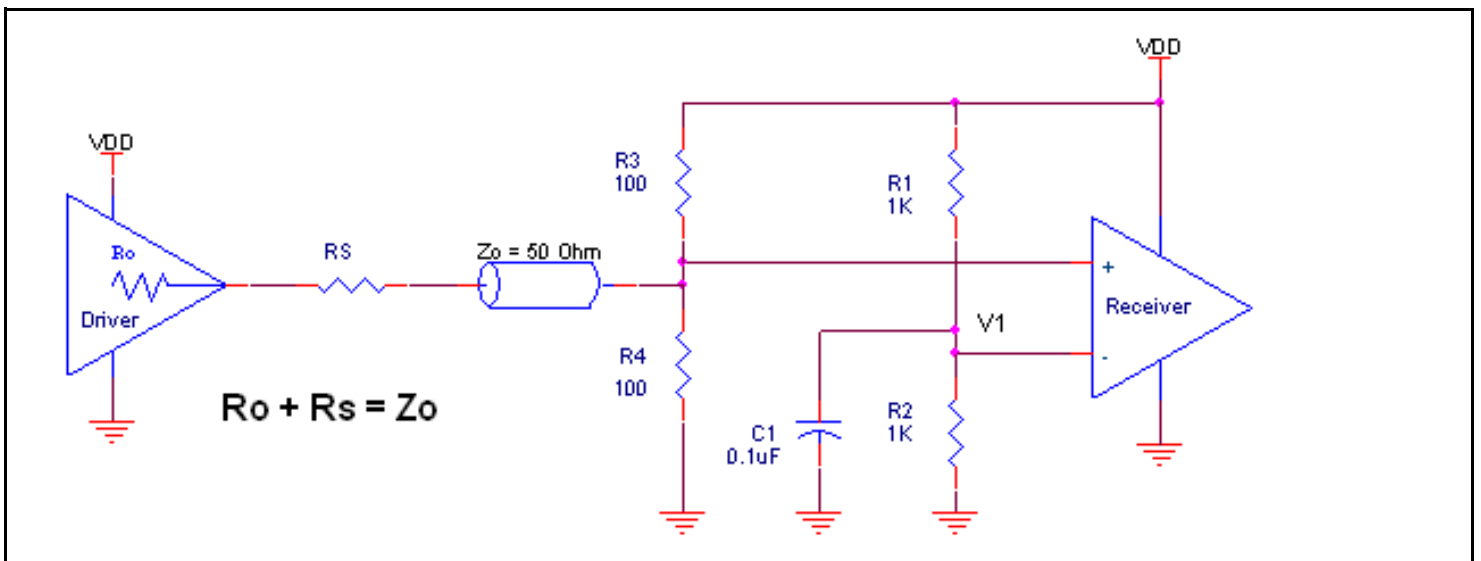
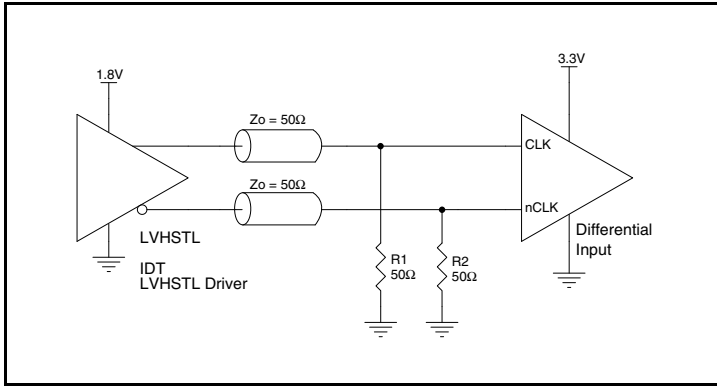

Figure 1. Recommended Schematic for Wiring a Differential Input to Accept Single-ended Levels

### 3.3V Differential Clock Input Interface

The CLK /nCLK accepts LVDS, LVPECL, LVHSTL, HCSL and other differential signals. Both  $V_{SWING}$  and  $V_{OH}$  must meet the  $V_{PP}$  and  $V_{CMR}$  input requirements. *Figures 2A to 2E* show interface examples for the CLK/nCLK input driven by the most common driver types. The input interfaces suggested here are examples only. Please consult

with the vendor of the driver component to confirm the driver termination requirements. For example, in Figure 2A, the input termination applies for IDT open emitter LVHSTL drivers. If you are using an LVHSTL driver from another vendor, use their termination recommendation.



**Figure 2A.** CLK/nCLK Input Driven by an IDT Open Emitter LVHSTL Driver

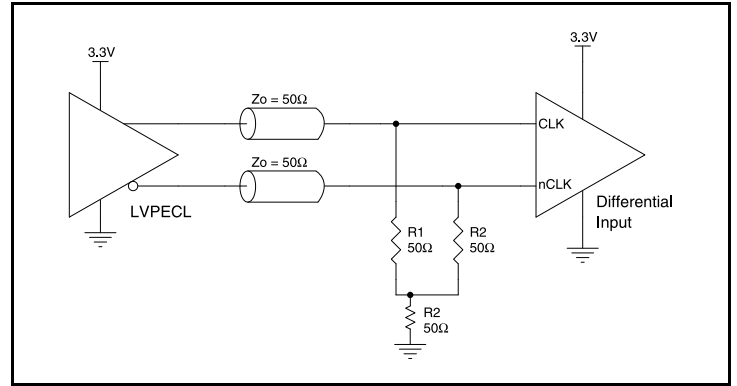

**Figure 2B.** CLK/nCLK Input Driven by a 3.3V LVPECL Driver

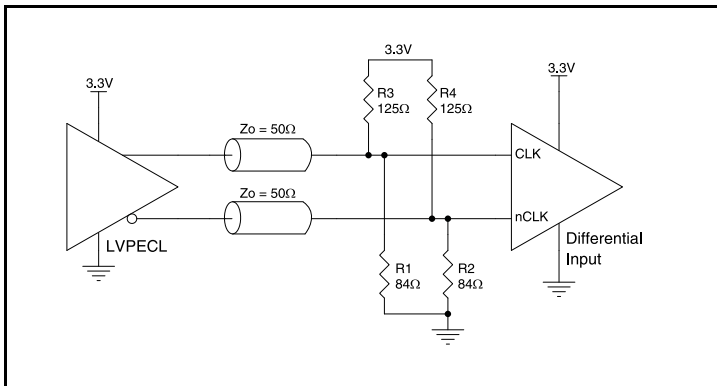

**Figure 2C.** CLK/nCLK Input Driven by a 3.3V LVPECL Driver

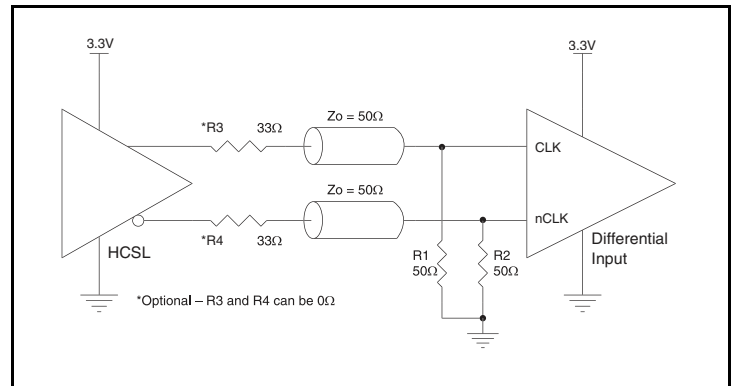

**Figure 2D.** CLK/nCLK Input Driven by a 3.3V HCSL Driver

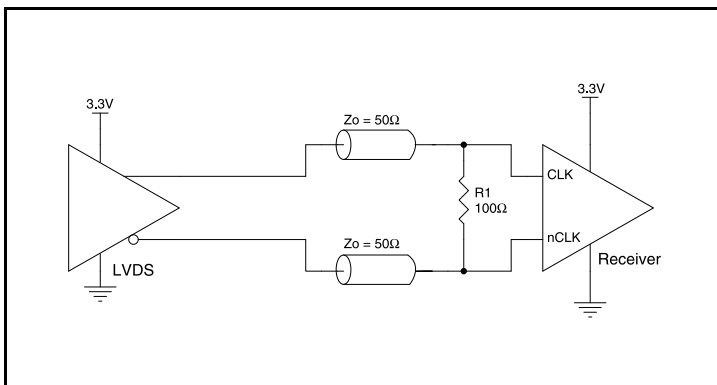

**Figure 2E.** CLK/nCLK Input Driven by a 3.3V LVDS Driver

## Overdriving the XTAL Interface

The XTAL\_IN input can be overdriven by an LVCMOS driver or by one side of a differential driver through an AC coupling capacitor. The XTAL\_OUT pin can be left floating. The amplitude of the input signal should be between 500mV and 1.8V and the slew rate should not be less than 0.2V/nS. For 3.3V LVCMOS inputs, the amplitude must be reduced from full swing to at least half the swing in order to prevent signal interference with the power rail and to reduce internal noise. *Figure 3A* shows an example of the interface diagram for a high speed 3.3V LVCMOS driver. This configuration requires that the sum of the output impedance of the driver ( $R_o$ ) and the series resistance ( $R_s$ ) equals the transmission line impedance. In addition, matched termination at the crystal input will attenuate the signal in half. This

can be done in one of two ways. First,  $R_1$  and  $R_2$  in parallel should equal the transmission line impedance. For most 50Ω applications,  $R_1$  and  $R_2$  can be 100Ω. This can also be accomplished by removing  $R_1$  and changing  $R_2$  to 50Ω. The values of the resistors can be increased to reduce the loading for a slower and weaker LVCMOS driver. *Figure 3B* shows an example of the interface diagram for an LVPECL driver. This is a standard LVPECL termination with one side of the driver feeding the XTAL\_IN input. It is recommended that all components in the schematics be placed in the layout. Though some components might not be used, they can be utilized for debugging purposes. The datasheet specifications are characterized and guaranteed by using a quartz crystal as the input.

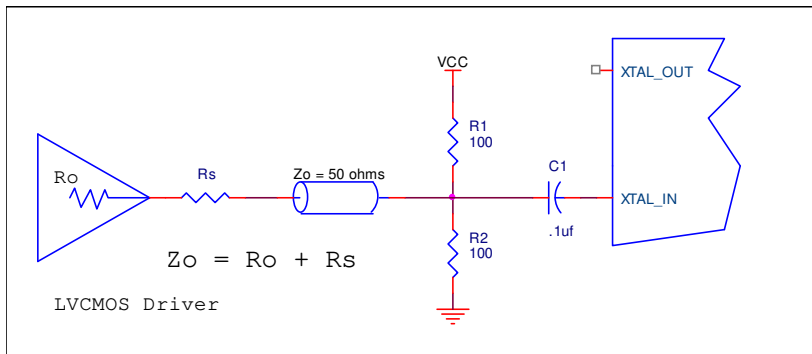

Figure 3A. General Diagram for LVCMOS Driver to XTAL Input Interface

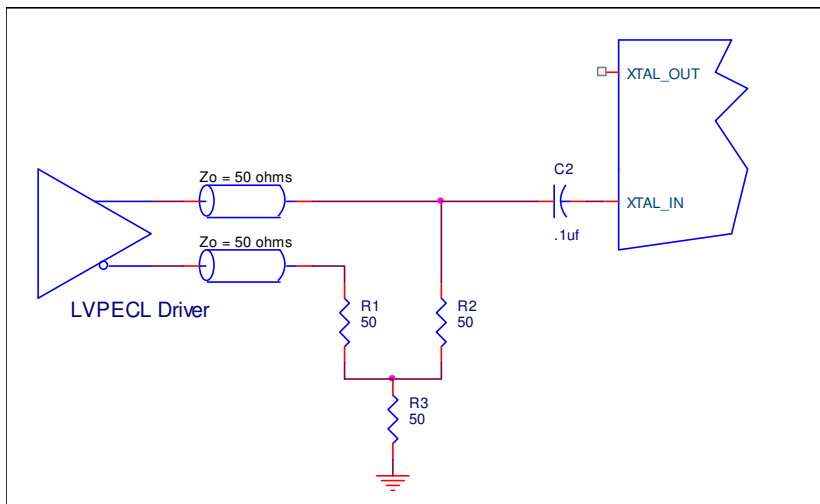
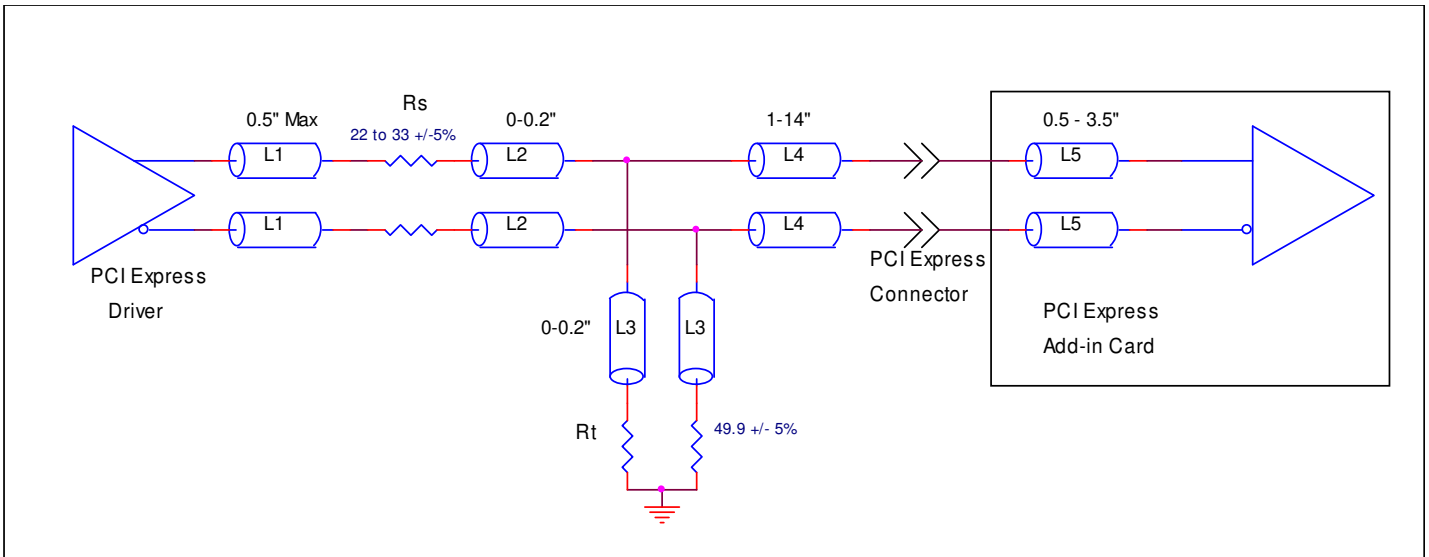

Figure 3B. General Diagram for LVPECL Driver to XTAL Input Interface

## Recommended Termination

Figure 4A is the recommended source termination for applications where the driver and receiver will be on a separate PCBs. This termination is the standard for PCI Express™ and HCSL output types.

All traces should be 50Ω impedance single-ended or 100Ω differential.



**Figure 4A. Recommended Source Termination (where the driver and receiver will be on separate PCBs)**

Figure 4B is the recommended termination for applications where a point-to-point connection can be used. A point-to-point connection contains both the driver and the receiver on the same PCB. With a matched termination at the receiver, transmission-line reflections will

be minimized. In addition, a series resistor ( $R_s$ ) at the driver offers flexibility and can help dampen unwanted reflections. The optional resistor can range from 0Ω to 33Ω. All traces should be 50Ω impedance single-ended or 100Ω differential.

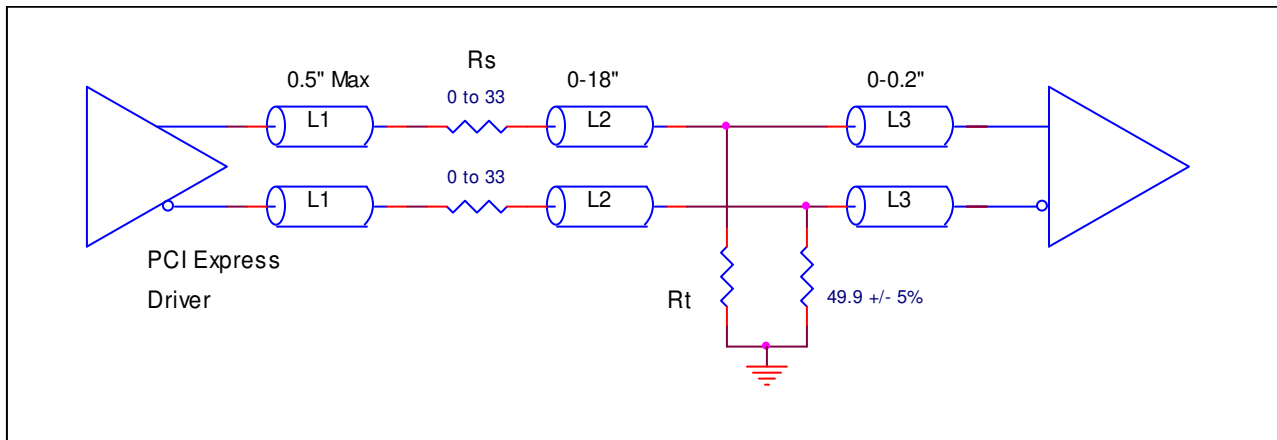

**Figure 4B. Recommended Termination (where a point-to-point connection can be used)**



## VFQFN EPAD Thermal Release Path

In order to maximize both the removal of heat from the package and the electrical performance, a land pattern must be incorporated on the Printed Circuit Board (PCB) within the footprint of the package corresponding to the exposed metal pad or exposed heat slug on the package, as shown in *Figure 5*. The solderable area on the PCB, as defined by the solder mask, should be at least the same size/shape as the exposed pad/slug area on the package to maximize the thermal/electrical performance. Sufficient clearance should be designed on the PCB between the outer edges of the land pattern and the inner edges of pad pattern for the leads to avoid any shorts.

While the land pattern on the PCB provides a means of heat transfer and electrical grounding from the package to the board through a solder joint, thermal vias are necessary to effectively conduct from the surface of the PCB to the ground plane(s). The land pattern must be connected to ground through these vias. The vias act as “heat pipes”. The number of vias (i.e. “heat pipes”) are application specific

and dependent upon the package power dissipation as well as electrical conductivity requirements. Thus, thermal and electrical analysis and/or testing are recommended to determine the minimum number needed. Maximum thermal and electrical performance is achieved when an array of vias is incorporated in the land pattern. It is recommended to use as many vias connected to ground as possible. It is also recommended that the via diameter should be 12 to 13mils (0.30 to 0.33mm) with 1oz copper via barrel plating. This is desirable to avoid any solder wicking inside the via during the soldering process which may result in voids in solder between the exposed pad/slug and the thermal land. Precautions should be taken to eliminate any solder voids between the exposed heat slug and the land pattern. Note: These recommendations are to be used as a guideline only. For further information, please refer to the Application Note on the Surface Mount Assembly of Amkor’s Thermally/Electrically Enhance Leadframe Base Package, Amkor Technology.

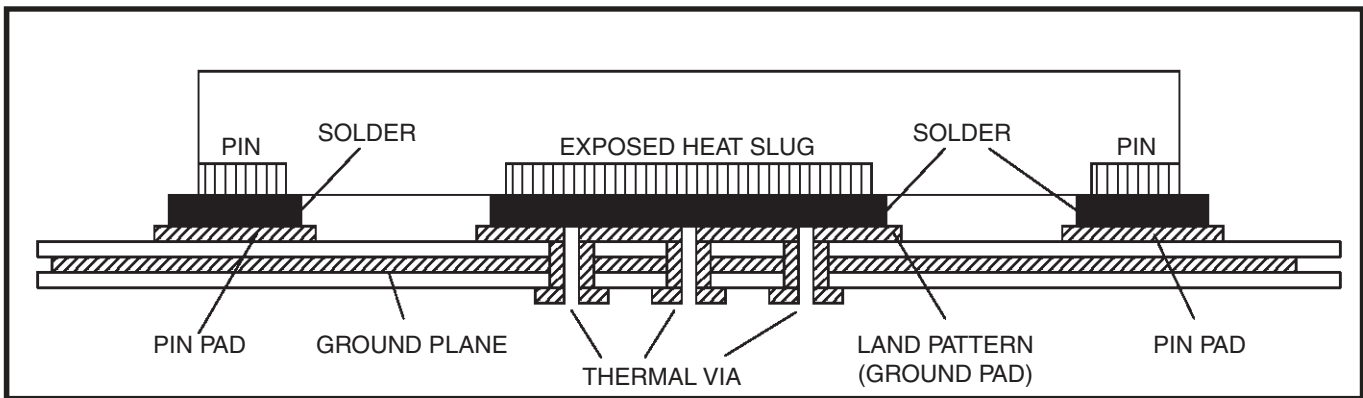

Figure 5. P.C. Assembly for Exposed Pad Thermal Release Path – Side View (drawing not to scale)

## Recommendations for Unused Input and Output Pins

### Inputs:

#### LVC MOS Control Pins

All control pins have internal pullups or pulldowns; additional resistance is not required but can be added for additional protection. A 1kΩ resistor can be used.

#### Crystal Inputs

For applications not requiring the use of the crystal oscillator input, both XTAL\_IN and XTAL\_OUT can be left floating. Though not required, but for additional protection, a 1kΩ resistor can be tied from XTAL\_IN to ground.

#### CLK/nCLK Inputs

For applications not requiring the use of the differential input, both CLK and nCLK can be left floating. Though not required, but for additional protection, a 1kΩ resistor can be tied from CLK to ground.

### Outputs:

#### LVC MOS Outputs

All unused LVC MOS outputs can be left floating. There should be no trace attached.

#### Differential Outputs

All unused differential outputs can be left floating. We recommend that there is no trace attached. Both sides of the differential output pair should either be left floating or terminated.

## PCI Express Application Note

PCI Express jitter analysis methodology models the system response to reference clock jitter. The block diagram below shows the most frequently used *Common Clock Architecture* in which a copy of the reference clock is provided to both ends of the PCI Express Link.

In the jitter analysis, the transmit (Tx) and receive (Rx) serdes PLLs are modeled as well as the phase interpolator in the receiver. These transfer functions are called H1, H2, and H3 respectively. The overall system transfer function at the receiver is:

$$H_t(s) = H_3(s) \times [H_1(s) - H_2(s)]$$

The jitter spectrum seen by the receiver is the result of applying this system transfer function to the clock spectrum X(s) and is:

$$Y(s) = X(s) \times H_3(s) \times [H_1(s) - H_2(s)]$$

In order to generate time domain jitter numbers, an inverse Fourier Transform is performed on X(s)\*H3(s) \* [H1(s) - H2(s)].

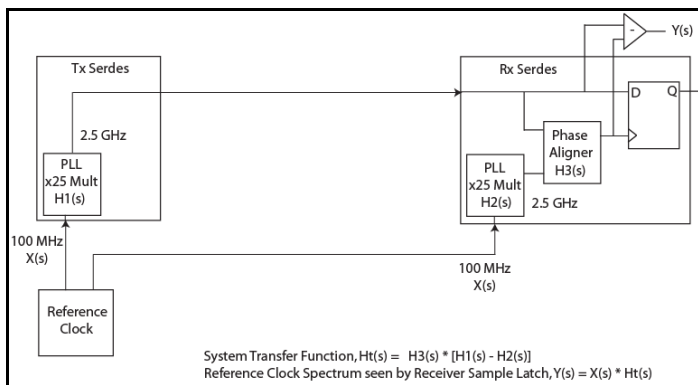

**PCI Express Common Clock Architecture**

For **PCI Express Gen 1**, one transfer function is defined and the evaluation is performed over the entire spectrum: DC to Nyquist (e.g for a 100MHz reference clock: 0Hz – 50MHz) and the jitter result is reported in peak-peak.

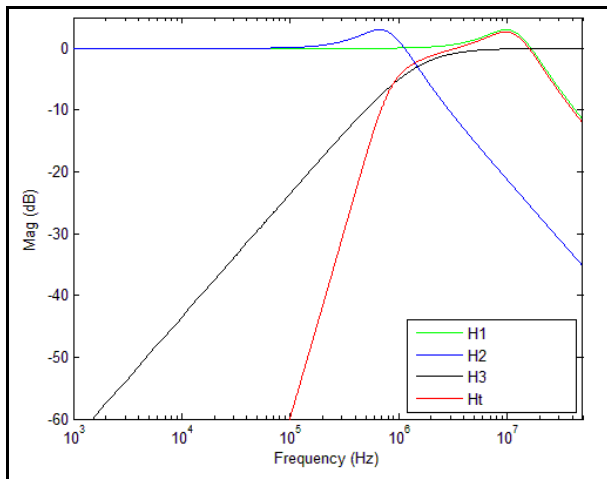

**PCI Express Gen 1 Magnitude of Transfer Function**

For **PCI Express Gen 2**, two transfer functions are defined with 2 evaluation ranges and the final jitter number is reported in RMS. The two evaluation ranges for PCI Express Gen 2 are 10kHz – 1.5MHz (Low Band) and 1.5MHz – Nyquist (High Band). The plots show the individual transfer functions as well as the overall transfer function Ht.

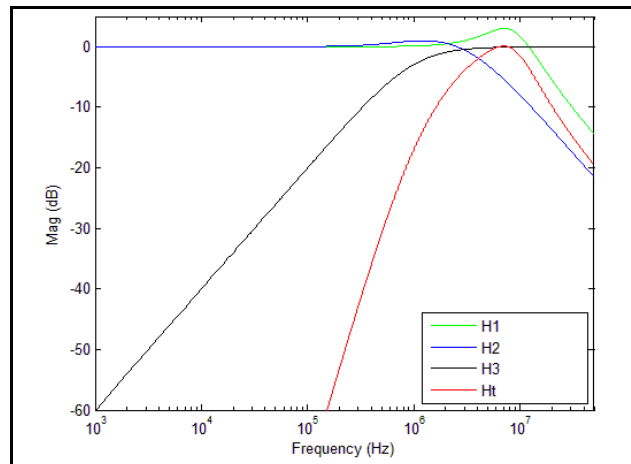

**PCI Express Gen 2A Magnitude of Transfer Function**

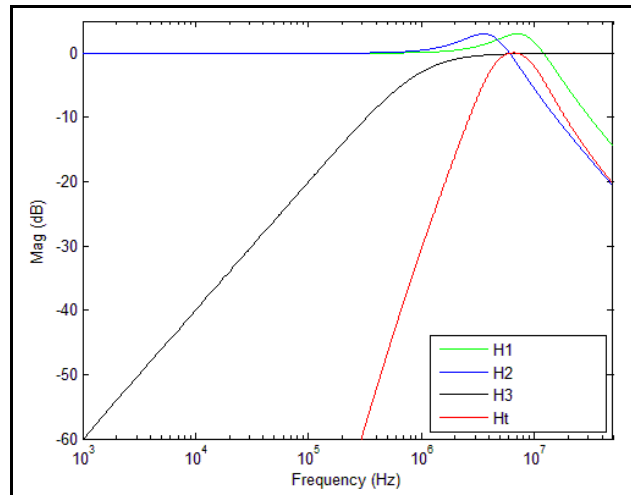

**PCI Express Gen 2B Magnitude of Transfer Function**

For **PCI Express Gen 3**, one transfer function is defined and the evaluation is performed over the entire spectrum. The transfer function parameters are different from Gen 1 and the jitter result is reported in RMS.

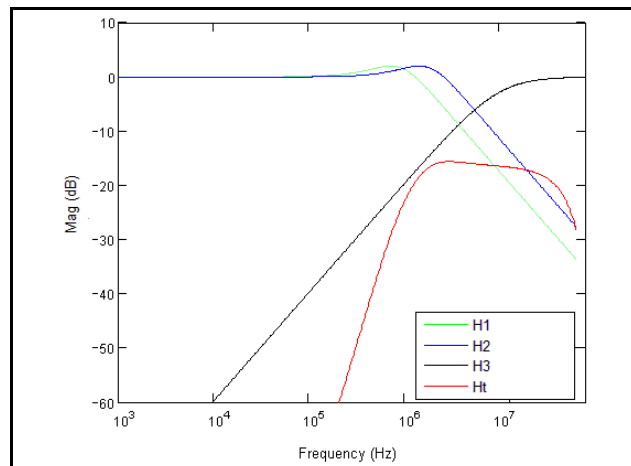

**PCI Express Gen 3 Magnitude of Transfer Function**

For a more thorough overview of PCI Express jitter analysis methodology, please refer to IDT Application Note *PCI Express Reference Clock Requirements*.

## Schematic Example

Figure 8 (next page) shows an example of 8V41N010 application schematic. In this example, the device is operated at  $V_{DD} = V_{DDA} = V_{DDO\_Qx} = 3.3V$ . The schematic example focuses on functional connections and is not configuration specific. Refer to the pin description and functional tables in the datasheet to ensure that the logic control inputs are properly set.

A 12pF parallel resonant 25MHz crystal is used. For this device, the crystal load capacitors are required for proper operation. The load capacitance,  $C1 = C2 = 2pF$ , are recommended for frequency accuracy. Depending on the variation of the parasitic stray capacity of the printed circuit board traces between the crystal and the XTAL\_IN and XTAL\_OUT pins, the values of C1 and C2 might require a slight adjustment to optimize the frequency accuracy. Crystals with other load capacitance specifications can be used, but this will require adjusting C1 and C2. When designing the circuit board, return the capacitors to ground through a single point contact close to the package. Two Fox crystal options are shown in the schematic for design flexibility.

The ePAD provides a low thermal impedance connection between the internal device and the PCB. It also provides an electrical connection to the die and must be connected to ground.

As with any high speed analog circuitry, the power supply pins are vulnerable to random noise. To achieve optimum jitter performance, power supply isolation is required. The 8V41N010 provides separate power supplies to isolate any high switching noise from coupling into the internal PLL.

In order to achieve the best possible filtering, it is recommended that the placement of the filter components be on the device side of the PCB as close to the power pins as possible. If space is limited, the 0.1μF capacitor in each power pin filter should be placed on the device side. The other components can be on the opposite side of the PCB.

Power supply filter recommendations are a general guideline to be used for reducing external noise from coupling into the devices. The filter performance is designed for a wide range of noise frequencies. This low-pass filter starts to attenuate noise at approximately 10kHz. If a specific frequency noise component is known, such as switching power supplies frequencies, it is recommended that component values be adjusted and if required, additional filtering be added. Additionally, good general design practices for power plane voltage stability suggests adding bulk capacitance in the local area of all devices.



## Power Considerations

This section provides information on power dissipation and junction temperature for the 8V41N010. Equations and example calculations are also provided.

### 1. Power Dissipation.

The total power dissipation for the 8V41N010 is the sum of the core power plus the analog power plus the power dissipated due to loading. The following is the power dissipation for  $V_{DD} = 3.3V + 5\% = 3.465V$ , which gives worst case results.

NOTE: Please refer to Section 3 for details on calculating power dissipated due to loading.

- Power (core)<sub>MAX</sub> =  $V_{DD\_MAX} * (I_{DD} + I_{DDA}) = 3.465V * (235mA + 47mA) = \mathbf{977.13mW}$
- Power (HCSL)<sub>MAX</sub> =  $(3.465V - 17mA * 50) 17mA = \mathbf{44.5mW}$  per output
- Total Power (HCSL)<sub>MAX</sub> =  $44.5mW * 8 = \mathbf{356mW}$
- Power (pre-driver)<sub>MAX</sub> =  $3.465V * 30mA = 103.95mW$

### LVC MOS Driver Power Dissipation

- Output Impedance  $R_{OUT}$  Power Dissipation due to Loading  $50\Omega$  to  $V_{DDO\_Qx} / 2$   
Output Current  $I_{OUT} = V_{DD\_MAX} / [2 * (50\Omega + R_{OUT})] = 3.465V / [2 * (50\Omega + 15\Omega)] = \mathbf{26.65mA}$
- Power Dissipation on the  $R_{OUT}$  per LVC MOS output  
Power (LVC MOS) =  $R_{OUT} * (I_{OUT})^2 = 15\Omega * (26.65mA)^2 = \mathbf{10.65mW}$  per output
- Total Power Dissipation on the  $R_{OUT}$   
Total Power ( $R_{OUT}$ ) =  $10.65mW * 1 = \mathbf{10.65mW}$
- Total Power Dissipation
- **Total Power**  
= Power (core) + Total Power (HCSL) + Power (pre-driver) + Total Power ( $R_{OUT}$ )  
=  $977.13mW + 356mW + 103.95mW + 10.65mW$   
=  $\mathbf{1447.73mW}$

### 2. Junction Temperature.

Junction temperature,  $T_j$ , is the temperature at the junction of the bond wire and bond pad directly affects the reliability of the device. The maximum recommended junction temperature is  $125^\circ\text{C}$ . Limiting the internal transistor junction temperature,  $T_j$ , to  $125^\circ\text{C}$  ensures that the bond wire and bond pad temperature remains below  $125^\circ\text{C}$ .

The equation for  $T_j$  is as follows:  $T_j = \theta_{JA} * Pd\_total + T_A$

$T_j$  = Junction Temperature

$\theta_{JA}$  = Junction-to-Ambient Thermal Resistance

$Pd\_total$  = Total Device Power Dissipation (example calculation is in section 1 above)

$T_A$  = Ambient Temperature

In order to calculate junction temperature, the appropriate junction-to-ambient thermal resistance  $\theta_{JA}$  must be used. Assuming no air flow and a multi-layer board, the appropriate value is  $26.6^\circ\text{C/W}$  per Table 9 below.

Therefore,  $T_j$  for an ambient temperature of  $85^\circ\text{C}$  with all outputs switching is:

$$85^\circ\text{C} + 1.448\text{W} * 26.6^\circ\text{C/W} = 123.5^\circ\text{C}. \text{ This is below the limit of } 125^\circ\text{C}.$$

This calculation is only an example.  $T_j$  will obviously vary depending on the number of loaded outputs, supply voltage, air flow and the type of board (multi-layer).

**Table 9. Thermal Resistance  $\theta_{JA}$  for 72 Lead VFQFN, Forced Convection**

$\theta_{JA}$ vs. Air Flow			
Meters per Second	0	1	2
Multi-Layer PCB, JEDEC Standard Test Boards	$26.6^\circ\text{C/W}$	$20^\circ\text{C/W}$	$17.9^\circ\text{C/W}$

### 3. Calculations and Equations.

The purpose of this section is to calculate power dissipation on the IC per HCSL output pair.

HCSL output driver circuit and termination are shown in *Figure 7*.

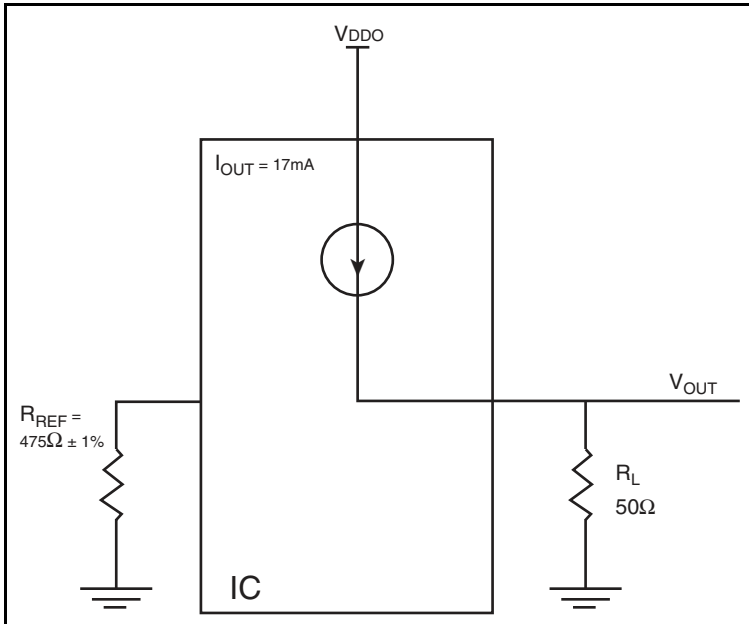

**Figure 7. HCSL Driver Circuit and Termination**

HCSL is a current steering output which sources a maximum of 17mA of current per output. To calculate worst case on-chip power dissipation, use the following equations which assume a 50Ω load to ground.

The highest power dissipation occurs when  $V_{DD\_MAX}$ .

$$\text{Power} = (V_{DD\_MAX} - V_{OUT}) * I_{OUT}$$

$$\text{since } V_{OUT} = I_{OUT} * R_L$$

$$\text{Power} = (V_{DD\_MAX} - I_{OUT} * R_L) * I_{OUT}$$

$$= (3.465V - 17mA * 50\Omega) * 17mA$$

Total Power Dissipation per output pair = **44.5mW**

## Reliability Information

**Table 10.  $\theta_{JA}$  vs. Air Flow Table for a 72 Lead VFQFN**

$\theta_{JA}$ vs. Air Flow			
Meters per Second	<b>0</b>	<b>1</b>	<b>2</b>
Multi-Layer PCB, JEDEC Standard Test Boards	26.6°C/W	20°C/W	17.9°C/W

## Transistor Count

The transistor count for 8V41N010 is: 175,936

## 72-Lead VFQFN (NL) Package Outline and Package Dimensions

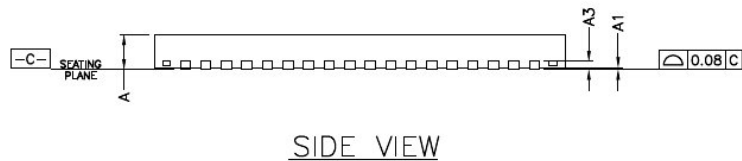
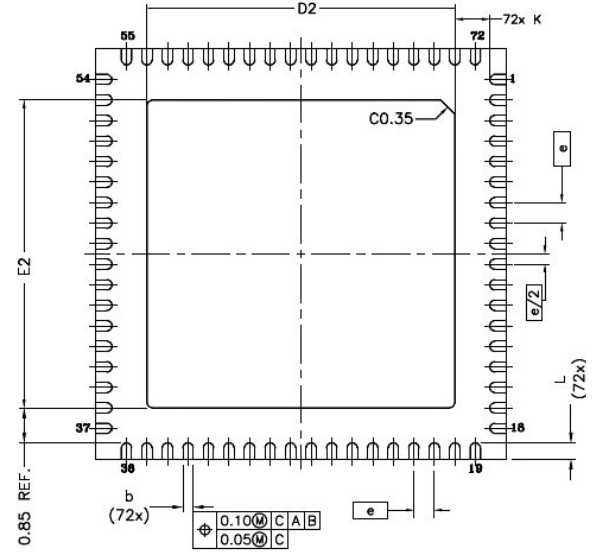
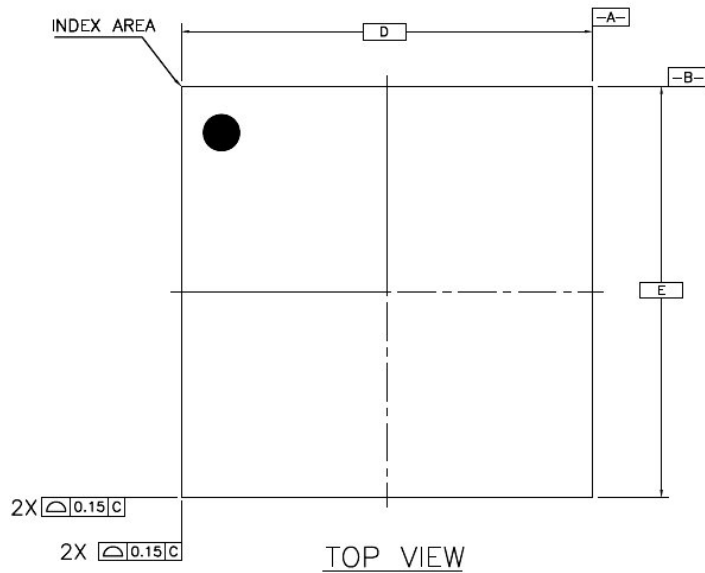

Table 8. Package Dimensions for 72-Lead Package<sup>1</sup>

SYMBOL	DIMENSIONS		
	MIN	NOM	MAX
D	10.00 BSC		
E	10.00 BSC		
D2	5.80	5.90	6.00
E2	5.80	5.90	6.00
K	0.20	-	-
L	0.30	0.40	0.50
A	0.80	0.90	1.00
A1	0.00	0.02	0.05
A2	0.00	0.65	1.00
A3	0.2 REF		
b	0.18	0.25	0.30
e	0.50 BSC		

NOTE 1. The drawing and dimension data originates from IDT Package Outline Drawing PSC-4208, Rev 04.

All dimensions and tolerances conform to ANSI Y14.5-1944.

All dimensions are in millimeters.

Index Area (Pin1 Identifier)



## Ordering Information

Table 11. Ordering Information

Part/Order Number	Marking	Package	Shipping Packaging	Temperature
8V41N010NLGI	IDT8V41N010NLGI	72 Lead VFQFN, Lead-Free	Tray	-40°C to 85°C
8V41N010NLGI8	IDT8V41N010NLGI	72 Lead VFQFN, Lead-Free	Tape & Reel	-40°C to 85°C



## IMPORTANT NOTICE AND DISCLAIMER

RENESAS ELECTRONICS CORPORATION AND ITS SUBSIDIARIES (“RENESAS”) PROVIDES TECHNICAL SPECIFICATIONS AND RELIABILITY DATA (INCLUDING DATASHEETS), DESIGN RESOURCES (INCLUDING REFERENCE DESIGNS), APPLICATION OR OTHER DESIGN ADVICE, WEB TOOLS, SAFETY INFORMATION, AND OTHER RESOURCES “AS IS” AND WITH ALL FAULTS, AND DISCLAIMS ALL WARRANTIES, EXPRESS OR IMPLIED, INCLUDING, WITHOUT LIMITATION, ANY IMPLIED WARRANTIES OF MERCHANTABILITY, FITNESS FOR A PARTICULAR PURPOSE, OR NON-INFRINGEMENT OF THIRD PARTY INTELLECTUAL PROPERTY RIGHTS.

These resources are intended for developers skilled in the art designing with Renesas products. You are solely responsible for (1) selecting the appropriate products for your application, (2) designing, validating, and testing your application, and (3) ensuring your application meets applicable standards, and any other safety, security, or other requirements. These resources are subject to change without notice. Renesas grants you permission to use these resources only for development of an application that uses Renesas products. Other reproduction or use of these resources is strictly prohibited. No license is granted to any other Renesas intellectual property or to any third party intellectual property. Renesas disclaims responsibility for, and you will fully indemnify Renesas and its representatives against, any claims, damages, costs, losses, or liabilities arising out of your use of these resources. Renesas' products are provided only subject to Renesas' Terms and Conditions of Sale or other applicable terms agreed to in writing. No use of any Renesas resources expands or otherwise alters any applicable warranties or warranty disclaimers for these products.

(Disclaimer Rev.1.0 Mar 2020)

### Corporate Headquarters

TOYOSU FORESIA, 3-2-24 Toyosu,  
Koto-ku, Tokyo 135-0061, Japan  
[www.renesas.com](http://www.renesas.com)

### Contact Information

For further information on a product, technology, the most up-to-date version of a document, or your nearest sales office, please visit:  
[www.renesas.com/contact/](http://www.renesas.com/contact/)

### Trademarks

Renesas and the Renesas logo are trademarks of Renesas Electronics Corporation. All trademarks and registered trademarks are the property of their respective owners.