

HUMIDITY/TEMPERATURE SENSOR WITH PWM OUTPUT

Features

- Precision Relative Humidity Sensor
 - ±5% RH (max), 0–90% RH
- High Accuracy Temperature Sensor
 - ±1 °C (max), –10 to 85 °C
- 0 to 100% RH operating range
- –40 to +125 °C operating range
- Wide operating voltage (1.9 to 3.6 V)
- Low Power Consumption
- Factory-calibrated
- PWM Output
- 3x3 mm DFN Package
- Excellent long term stability
- Optional factory-installed cover
 - Low-profile
 - Protection during reflow
 - Excludes liquids and particulates

Applications

- HVAC/R
- Thermostats/humidistats
- Respiratory therapy
- White goods
- Indoor weather stations
- Micro-environments/data centers
- Automotive climate control and defogging
- Asset and goods tracking
- Mobile phones and tablets

Description

The Si7007 Humidity and Temperature Sensor is a monolithic CMOS IC integrating humidity and temperature sensor elements, an analog-to-digital converter, signal processing, calibration data, and a PWM output. The PWM output may be filtered to produce an analog voltage output. The patented use of industry-standard, low-K polymeric dielectrics for sensing humidity enables the construction of low-power, monolithic CMOS Sensor ICs with low drift and hysteresis, and excellent long term stability.

The humidity and temperature sensors are factory-calibrated and the calibration data is stored in the on-chip non-volatile memory. This ensures that the sensors are fully interchangeable, with no recalibration or software changes required.

The Si7007 is available in a 3x3 mm DFN package and is reflow solderable. It can be used as a hardware- and software-compatible drop-in upgrade for existing RH/temperature sensors in 3x3 mm DFN-6 packages, featuring precision sensing over a wider range and lower power consumption. The optional factory-installed cover offers a low profile, convenient means of protecting the sensor during assembly (e.g., reflow soldering) and throughout the life of the product, excluding liquids (hydrophobic/oleophobic) and particulates.

The Si7007 offers an accurate, low-power, factory-calibrated digital solution ideal for measuring humidity, dew-point, and temperature, in applications ranging from HVAC/R and asset tracking to industrial and consumer platforms.

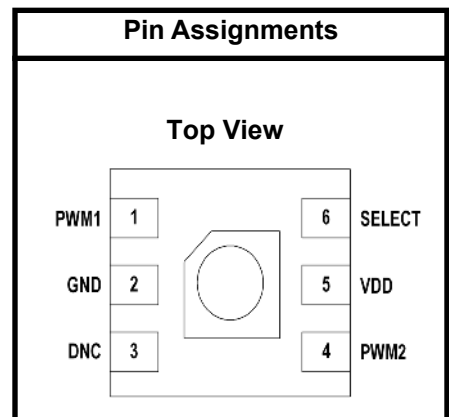

Patent Protected. Patents pending

Si7007-A10

Functional Block Diagram

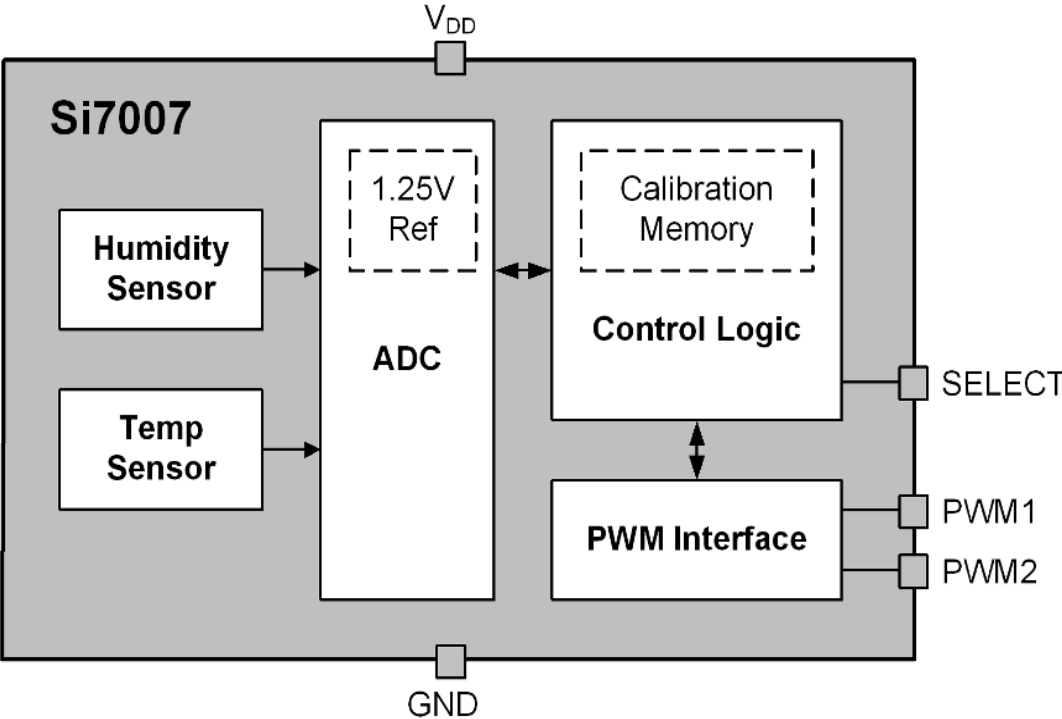

TABLE OF CONTENTS

| <u>Section</u> | <u>Page</u> |
|---|--------------------|
| 1. Electrical Specifications | 4 |
| 2. Typical Application Circuits | 9 |
| 3. Bill of Materials | 10 |
| 4. Functional Description | 11 |
| 4.1. Relative Humidity Sensor Accuracy | 12 |
| 4.2. Hysteresis | 13 |
| 4.3. Prolonged Exposure to High Humidity | 13 |
| 4.4. PCB Assembly | 13 |
| 4.5. Protecting the Sensor | 15 |
| 4.6. Bake/Hydrate Procedure | 15 |
| 4.7. Long Term Drift/Aging | 15 |
| 5. PWM Output | 16 |
| 6. Pin Descriptions: Si7007 (Top View) | 17 |
| 7. Ordering Guide | 18 |
| 8. Package Outline | 19 |
| 8.1. Package Outline: 3x3 6-pin DFN | 19 |
| 8.2. Package Outline: 3x3 6-pin DFN with Protective Cover | 20 |
| 9. PCB Land Pattern and Solder Mask Design | 21 |
| 10. Top Marking | 22 |
| 10.1. Si7007 Top Marking | 22 |
| 10.2. Top Marking Explanation | 22 |
| 11. Additional Reference Resources | 23 |
| Document Change List | 24 |
| Contact Information | 25 |

Si7007-A10

1. Electrical Specifications

Unless otherwise specified, all min/max specifications apply over the recommended operating conditions.

Table 1. Recommended Operating Conditions

| Parameter | Symbol | Test Condition | Min | Typ | Max | Unit |
|-----------------------|-----------------|----------------|-----|-----|------|------|
| Power Supply | V _{DD} | | 1.9 | — | 3.6 | V |
| Operating Temperature | T _A | | -40 | — | +125 | °C |

Table 2. General Specifications

1.9 ≤ V_{DD} ≤ 3.6 V; T_A = -40 to 125 °C unless otherwise noted.

| Parameter | Symbol | Test Condition | Min | Typ | Max | Unit |
|---------------------|-----------------|---|-----------------------|-----|---------------------|------|
| Input Voltage High | V _{IH} | SELECT pin | 0.7xV _{DD} | — | — | V |
| Input Voltage Low | V _{IL} | SELECT pin | — | — | 0.3xV _{DD} | V |
| Input Voltage Range | V _{IN} | SELECT pin with respect to GND | 0.0 | — | V _{DD} | V |
| Input Leakage | I _{IL} | SELECT pin | — | — | 1 | μA |
| Output Voltage High | V _{OH} | PWM1, PWM2 pins, I _{OH} = -10 μA | V _{DD} - 0.1 | — | — | V |
| | | PWM1, PWM2 pins pin, I _{OH} = -0.5 mA, V _{DD} = 2.0 V | V _{DD} - 0.2 | — | — | V |
| | | PWM1, PWM2 pins, I _{OH} = -1.7 mA, V _{DD} = 3.0 V | V _{DD} - 0.4 | — | — | V |
| Output Voltage Low | V _{OL} | PWM1, PWM2 pins; I _{OL} = 2.5 mA; V _{DD} = 3.3 V | — | — | 0.6 | V |
| | | PWM1, PWM2 pins; I _{OL} = 1.2 mA; V _{DD} = 1.9 V | — | — | 0.4 | V |
| Sample Rate | | RH and Temperature | — | 2 | — | Hz |
| Current Consumption | I _{DD} | Average Current | — | 150 | 300 | μA |
| Powerup Time | t _{PU} | From V _{DD} ≥ 1.9 V to PWM output enabled, 25 °C | — | 48 | 55 | ms |
| | | From V _{DD} ≥ 1.9 V to PWM output enabled, full temperature range | — | — | 110 | |

Table 3. PWM Interface Specifications

$1.9 \leq V_{DD} \leq 3.6$ V; $T_A = -40$ to $+125$ °C unless otherwise noted.

| Parameter | Symbol | Test Condition | Min | Typ | Max | Unit |
|-------------------|-----------------|-------------------------------------|------|------|------|------|
| PWM Frequency | FPWM | | 1.00 | 1.22 | 1.40 | kHz |
| PWM Duty Cycle | DCPWM | $t_H / t_{P_{PWM}}$ | 0 | — | 100 | % |
| SELECT Setup Time | t _{SS} | From SELECT transition to PWM valid | — | 500 | — | ms |

**Figure 1. PWM Interface Timing Diagram**

Table 4. Humidity Sensor

$1.9 \leq V_{DD} \leq 3.6 \text{ V}$; $T_A = 30 \text{ }^\circ\text{C}$

| Parameter | Symbol | Test Condition | Min | Typ | Max | Unit |
|----------------------------------|------------|--------------------------------------|--------------|--------|-----|---------|
| Operating Range ¹ | | Non-condensing | 0 | — | 100 | %RH |
| Accuracy ^{2, 3} | | 0 – 90% RH | — | ±4 | ±5 | %RH |
| | | 90 – 100% RH | See Figure 2 | | | |
| Repeatability/Noise | | | — | 0.025 | — | %RH RMS |
| Resolution | | | — | 11 | — | Bits |
| Response Time ⁴ | $T_{63\%}$ | 1 m/s airflow, with or without cover | — | 6 | — | S |
| Drift vs. Temperature | | | — | 0.05 | — | %RH/°C |
| Hysteresis | | | — | ±1 | — | %RH |
| Long Term Stability ³ | | | — | < 0.25 | — | %RH/yr |

Notes:

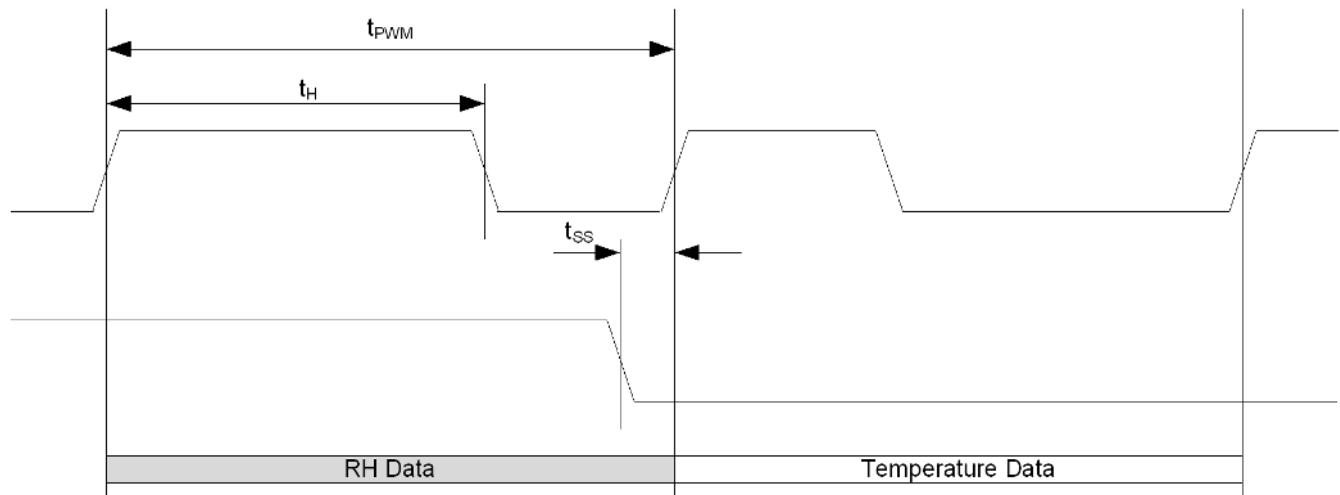
1. Recommended humidity operating range is 20% to 80% RH (non-condensing) over $-10 \text{ }^\circ\text{C}$ to $60 \text{ }^\circ\text{C}$. Prolonged operation beyond these ranges may result in a shift of sensor reading, with slow recovery time.
2. Excludes hysteresis, long term drift, and certain other factors and is applicable to non-condensing environments only. See section “4.1. Relative Humidity Sensor Accuracy” for more details.
3. Drift due to aging effects at typical room conditions of $30 \text{ }^\circ\text{C}$ and 30% to 50% RH. May be impacted by dust, vaporized solvents or other contaminants, e.g., out-gassing tapes, adhesives, packaging materials, etc. See section “4.7. Long Term Drift/Aging” .
4. Response time to a step change in RH. Time for the RH output to change by 63% of the total RH change.

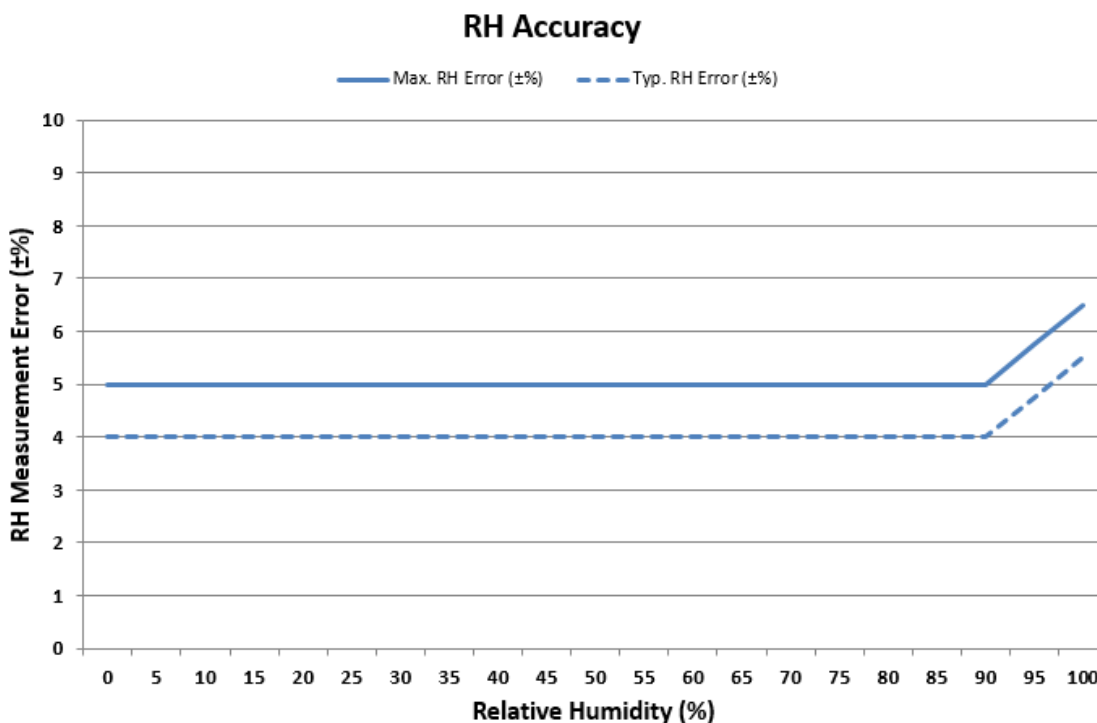

Figure 2. RH Accuracy at 30 °C

Table 5. Temperature Sensor

$1.9 \leq V_{DD} \leq 3.6$ V; $T_A = -40$ to $+125$ °C unless otherwise noted.

| Parameter | Symbol | Test Condition | Min | Typ | Max | Unit |
|---------------------|------------|--------------------------------|----------|-------------|---------|--------|
| Operating Range | | | -40 | — | +125 | °C |
| Accuracy | | -10 °C $\leq t_A \leq 85$ °C | — | ± 0.5 | ± 1 | °C |
| | | $-40 \leq t_A \leq 125$ °C | Figure 3 | | | °C |
| Repeatability/Noise | | | — | 0.04 | — | °C RMS |
| Resolution | | | — | 11 | — | Bits |
| Response Time* | $T_{63\%}$ | Unmounted device | — | 0.7 | — | s |
| | | Si7007-EB board | — | 5.1 | — | |
| Long Term Stability | | | — | ≤ 0.01 | — | °C/Yr |

***Note:** Time to reach 63% of final value in response to a step change in temperature. Actual response time will vary dependent on system thermal mass and air-flow.

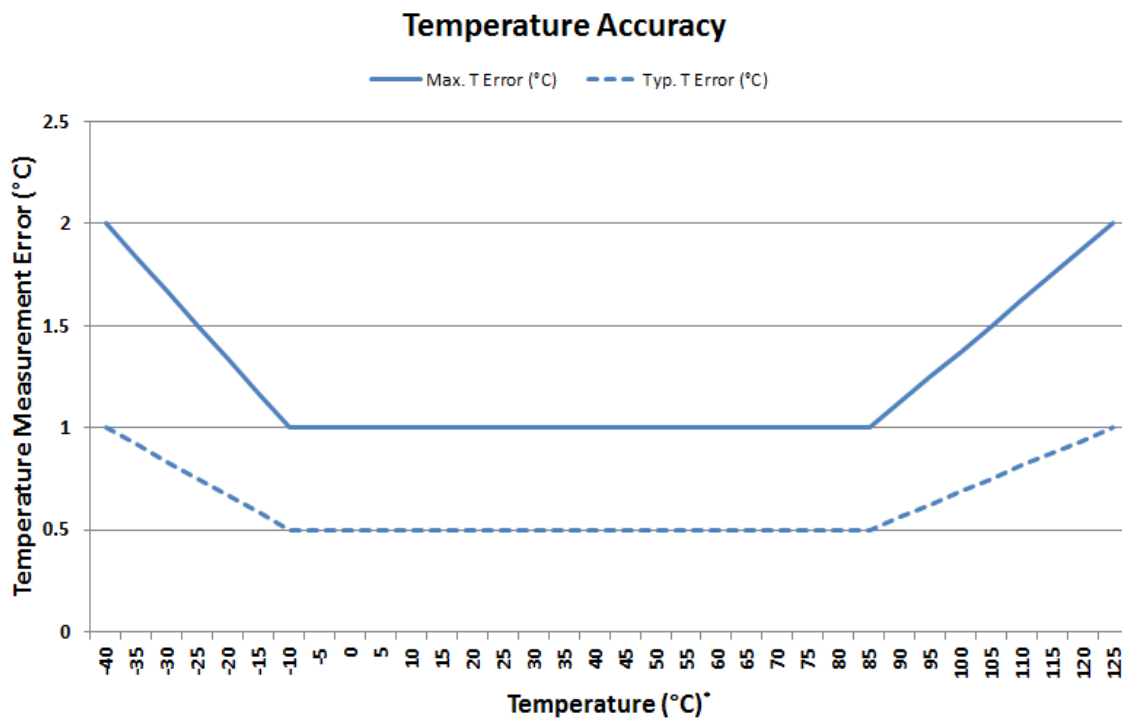
**Figure 3. Temperature Accuracy**

Si7007-A10

Table 6. Thermal Characteristics

| Parameter | Symbol | Test Condition | DFN-6 | Unit |
|--------------------------------------|---------------|---|-------|------|
| Junction to Air Thermal Resistance | θ_{JA} | JEDEC 2-Layer board, No Airflow | 256 | °C/W |
| Junction to Air Thermal Resistance | θ_{JA} | JEDEC 2-Layer board, 1 m/s Airflow | 224 | °C/W |
| Junction to Air Thermal Resistance | θ_{JA} | JEDEC 2-Layer board, 2.5 m/s Airflow | 205 | °C/W |
| Junction to Case Thermal Resistance | θ_{JC} | JEDEC 2-Layer board | 22 | °C/W |
| Junction to Board Thermal Resistance | θ_{JB} | JEDEC 2-Layer board | 134 | °C/W |

Table 7. Absolute Maximum Ratings¹

| Parameter | Symbol | Test Condition | Min | Typ | Max | Unit |
|------------------------------------|--------|----------------|------|-----|----------|------|
| Ambient temperature under bias | | | -55 | — | 125 | °C |
| Storage Temperature ² | | | -65 | — | 150 | °C |
| Voltage on I/O pins | | | -0.3 | — | VDD+0.3V | V |
| Voltage on VDD with respect to GND | | | -0.3 | — | 4.2 | V |
| ESD Tolerance | | HBM | — | — | 2 | kV |
| | | CDM | — | — | 1.25 | kV |
| | | MM | — | — | 250 | V |

Notes:

1. Absolute maximum ratings are stress ratings only, operation at or beyond these conditions is not implied and may shorten the life of the device or alter its performance.
2. Special handling considerations apply; see application note, “AN607: Si70xx Humidity Sensor Designer’s Guide”.

2. Typical Application Circuits

The primary function of the Si7007 is to measure relative humidity and temperature. Figure 4 demonstrates the typical application circuit to achieve these functions.

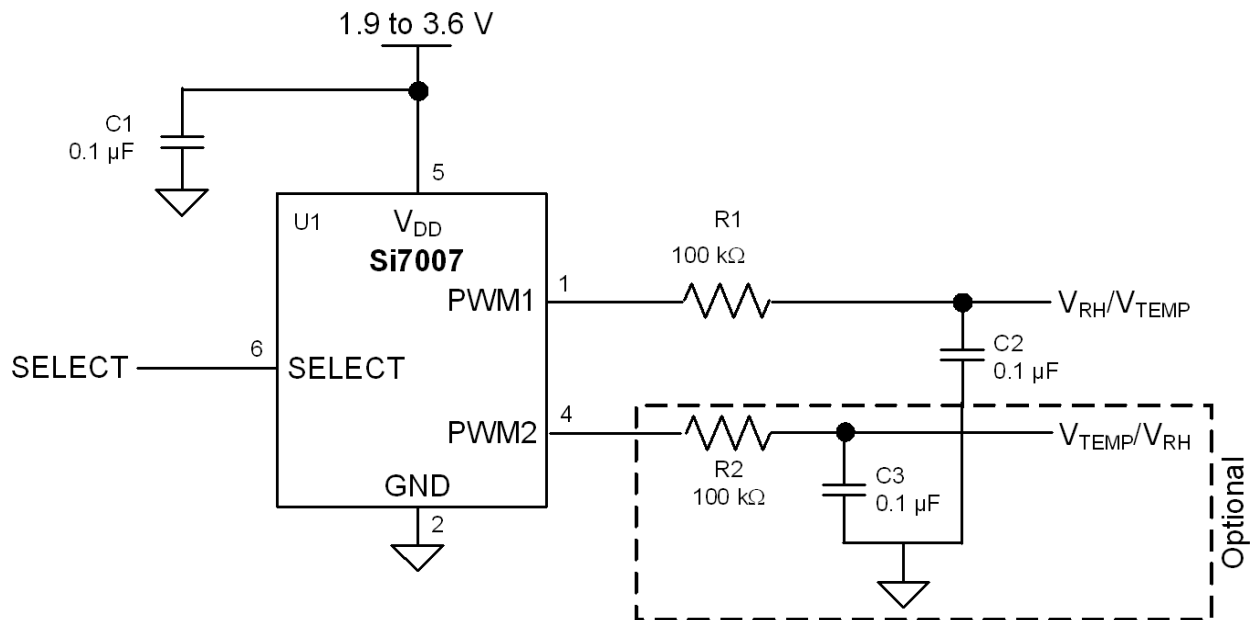

Figure 4. Typical Application Circuit for Relative Humidity and Temperature Measurement

3. Bill of Materials

Table 8. Typical Application Circuit BOM for Relative Humidity and Temperature Measurement

| Reference | Description | Mfr Part Number | Manufacturer |
|-----------|--|-----------------|--------------|
| C1 | Capacitor, 0.1 μ F, 16 V, X7R, 0603 | Various | Various |
| R1 | Resistor, 100 k Ω , \pm 5%, 1/16 W, 0603 | Various | Various |
| C2 | Capacitor, 1 μ F, 16 V, X7R, 0603 | Various | Various |
| R2 | Resistor, 100 k Ω , \pm 5%, 1/16 W, 0603 (optional) | Various | Various |
| C3 | Capacitor, 1 μ F, 16 V, X7R, 0603 (optional) | Various | Various |
| U1 | IC, Digital Temp/Humidity Sensor | Si7007-A10 | Silicon Labs |

4. Functional Description

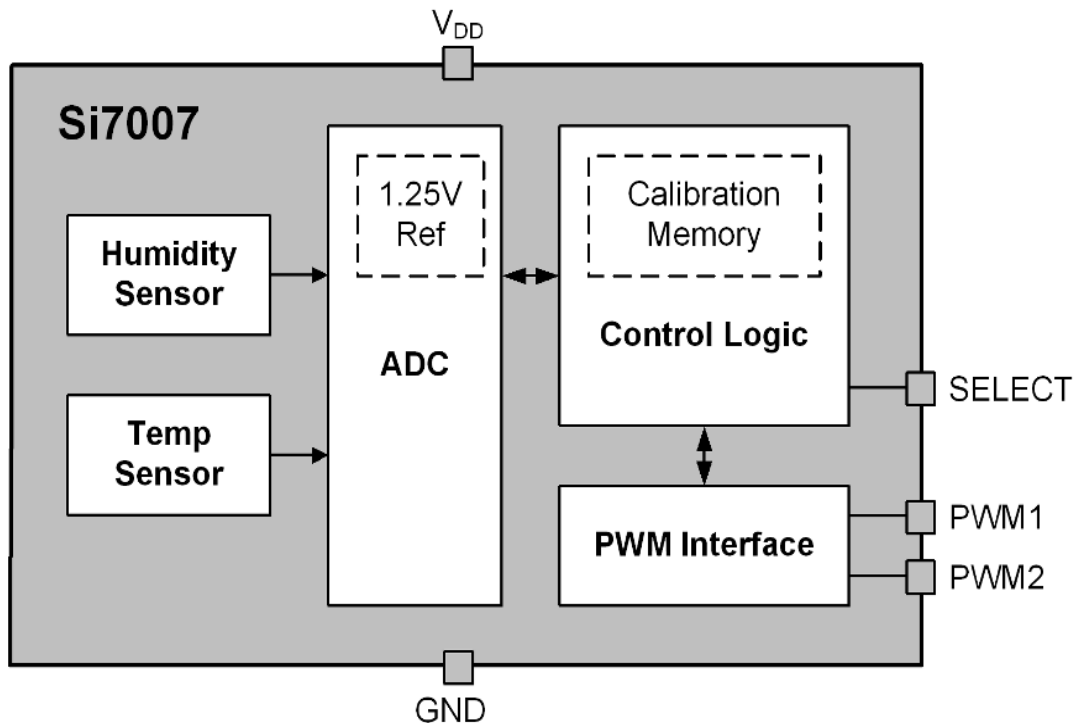

Figure 5. Si7007 Block Diagram

The Si7007 is a digital relative humidity and temperature sensor that integrates temperature and humidity sensor elements, an analog-to-digital converter, signal processing, calibration, polynomial non-linearity correction, and a PWM output all in a single chip. The Si7007 is individually factory-calibrated for both temperature and humidity, with the calibration data stored in on-chip, non-volatile memory. This ensures that the sensor is fully interchangeable, with no recalibration or changes to software required. Patented use of industry-standard CMOS and low-K dielectrics as a sensor enables the Si7007 to achieve excellent long term stability and immunity to contaminants with low drift and hysteresis. The Si7007 offers a low power, high accuracy, calibrated and stable solution ideal for a wide range of temperature, humidity, and dew-point applications including medical and instrumentation, high reliability automotive and industrial systems, and cost-sensitive consumer electronics.

While the Si7007 is largely a conventional mixed-signal CMOS integrated circuit, relative humidity sensors in general and those based on capacitive sensing using polymeric dielectrics have unique application and use requirements that are not common to conventional (non-sensor) ICs. Chief among those are:

- The need to protect the sensor during board assembly, i.e., solder reflow, and the need to subsequently rehydrate the sensor.
- The need to protect the sensor from damage or contamination during the product life-cycle.
- The impact of prolonged exposure to extremes of temperature and/or humidity and their potential effect on sensor accuracy.
- The effects of humidity sensor “memory”.

Each of these items is discussed in more detail in the following sections.

4.1. Relative Humidity Sensor Accuracy

To determine the accuracy of a relative humidity sensor, it is placed in a temperature and humidity controlled chamber. The temperature is set to a convenient fixed value (typically 25–30 °C) and the relative humidity is swept from 20 to 80% and back to 20% in the following steps: 20% – 40% – 60% – 80% – 80% – 60% – 40% – 20%. At each set-point, the chamber is allowed to settle for a period of 60 minutes before a reading is taken from the sensor. Prior to the sweep, the device is allowed to stabilize to 50%RH. The solid trace in Figure 6, “Measuring Sensor Accuracy Including Hysteresis,” shows the result of a typical sweep.

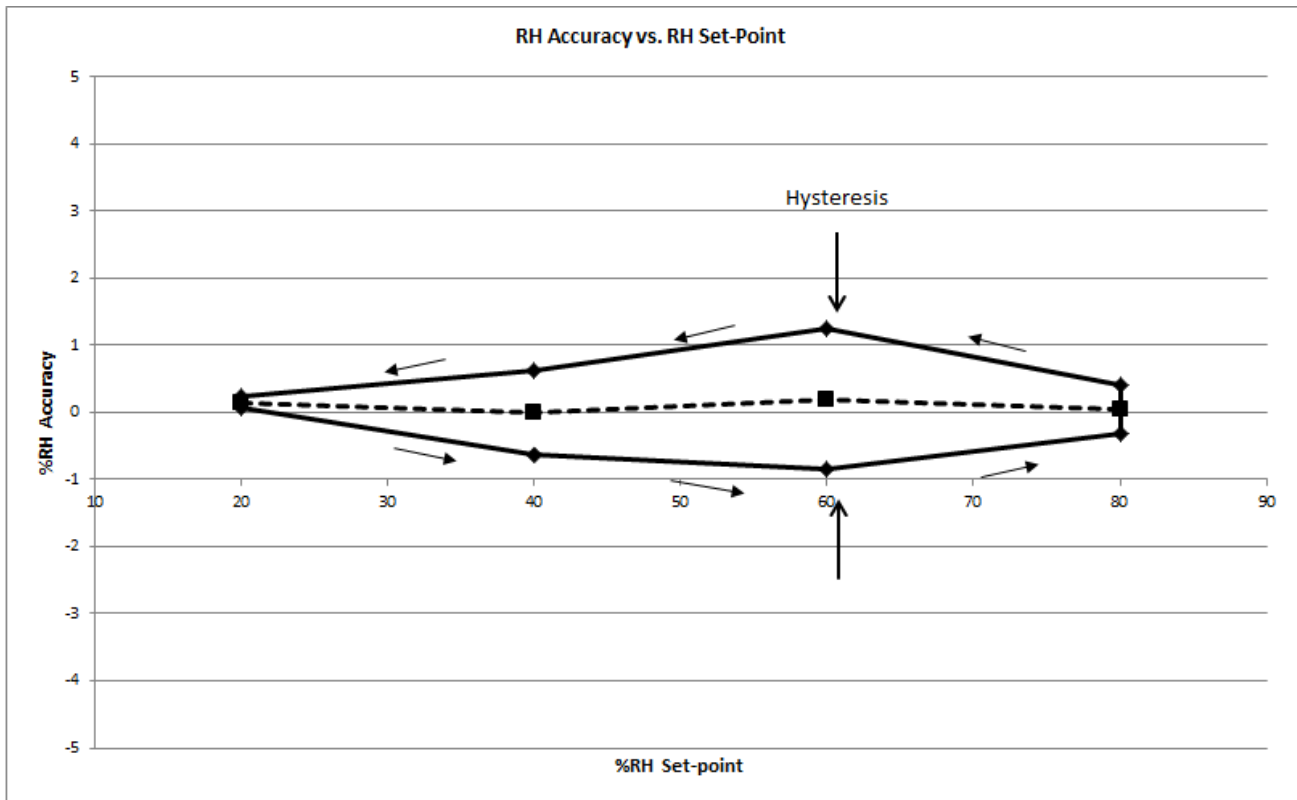

Figure 6. Measuring Sensor Accuracy Including Hysteresis

The RH accuracy is defined as the dotted line shown in Figure 6, which is the average of the two data points at each relative humidity set-point. In this case, the sensor shows an accuracy of 0.25%RH. The Si7007 accuracy specification (Table 4) includes:

- Unit-to-unit and lot-to-lot variation
- Accuracy of factory calibration
- Margin for shifts that can occur during solder reflow

The accuracy specification does not include:

- Hysteresis (typically $\pm 1\%$)
- Effects from long term exposure to very humid conditions
- Contamination of the sensor by particulates, chemicals, etc.
- Other aging related shifts ("Long-term stability")
- Variations due to temperature (see Drift vs. Temperature in Table 4). RH readings will typically vary with temperature by less than $\pm 0.05\% \text{ } ^\circ\text{C}$.

4.2. Hysteresis

The moisture absorbent film (polymeric dielectric) of the humidity sensor will carry a memory of its exposure history, particularly its recent or extreme exposure history. A sensor exposed to relatively low humidity will carry a negative offset relative to the factory calibration, and a sensor exposed to relatively high humidity will carry a positive offset relative to the factory calibration. This factor causes a hysteresis effect illustrated by the solid trace in Figure 6. The hysteresis value is the difference in %RH between the maximum absolute error on the decreasing humidity ramp and the maximum absolute error on the increasing humidity ramp at a single relative humidity setpoint and is expressed as a bipolar quantity relative to the average error (dashed trace). In the example of Figure 6, the measurement uncertainty due to the hysteresis effect is $\pm 1.0\%RH$.

4.3. Prolonged Exposure to High Humidity

Prolonged exposure to high humidity will result in a gradual upward drift of the RH reading. The shift in sensor reading resulting from this drift will generally disappear slowly under normal ambient conditions. The amount of shift is proportional to the magnitude of relative humidity and the length of exposure. In the case of lengthy exposure to high humidity, some of the resulting shift may persist indefinitely under typical conditions. It is generally possible to substantially reverse this effect by baking the device (see Section "4.6. Bake/Hydrate Procedure").

4.4. PCB Assembly

4.4.1. Soldering

Like most ICs, Si7007 devices are shipped from the factory vacuum-packed with an enclosed desiccant to avoid any RH accuracy drift during storage and to prevent any moisture-related issues during solder reflow. The following guidelines should be observed during PCB assembly:

- Si7007 devices are compatible with standard board assembly processes. Devices should be soldered using reflow per the recommended card reflow profile. (See Section "9. PCB Land Pattern and Solder Mask Design" for the recommended card reflow profile.)
- A "no clean" solder process is recommended to minimize the need for water or solvent rinses after soldering. Cleaning after soldering is possible, but must be done carefully to avoid impacting the performance of the sensor. (See AN607 for more information on cleaning.)
- It is essential that the exposed polymer sensing film be kept clean and undamaged. This can be accomplished by careful handling and a clean, well-controlled assembly process. When in doubt or for extra protection, a heat-resistant, protective cover such as Kapton™ KPPD-1/8 polyimide tape can be installed during PCB assembly.

Si7007s may be ordered with a factory-fitted, solder-resistant protective cover. This cover provides protection during PCB assembly or rework but without the time and effort required to install and remove the Kapton tape. It can be left in place for the lifetime of the product, preventing liquids, dust or other contaminants from coming into contact with the polymer sensor film. See Section "7. Ordering Guide" for a list of ordering part numbers that include the cover.

4.4.2. Rehydration

The measured humidity value will generally shift slightly after solder reflow. A portion of this shift is permanent and is accounted for in the accuracy specifications in Table 4. After soldering, an Si7007 should be allowed to equilibrate under controlled RH conditions (room temperature, 45–55%RH) for at least 48 hours to eliminate the remainder of the shift and return the device to its specified accuracy performance.

4.4.3. Rework

To maintain the specified sensor performance, care must be taken during rework to minimize the exposure of the device to excessive heat and to avoid damage/contamination or a shift in the sensor reading due to liquids, solder flux, etc. Manual touch-up using a soldering iron is permissible under the following guidelines:

- The exposed polymer sensing film must be kept clean and undamaged. A protective cover is recommended during any rework operation (Kapton® tape or the factory installed cover).
- Flux must not be allowed to contaminate the sensor; liquid flux is not recommended even with a cover in place. Conventional lead-free solder with rosin core is acceptable for touch-up as long as a cover is in place during the rework.
- If possible, avoid water or solvent rinses after touch-up. Cleaning after soldering is possible, but must be done carefully to avoid impacting the performance of the sensor. See AN607 for more information on cleaning.
- Minimize the heating of the device. Soldering iron temperatures should not exceed 350 °C and the contact time per pin should not exceed 5 seconds.
- Hot air rework is not recommended. If a device must be replaced, remove the device by hot air and solder a new part in its place by reflow following the guidelines above.

***Note:** All trademarks are the property of their respective owners.



Figure 7. Si7007 with Factory-Installed Protective Cover

4.5. Protecting the Sensor

Because the sensor operates on the principal of measuring a change in capacitance, any changes to the dielectric constant of the polymer film will be detected as a change in relative humidity. Therefore, it is important to minimize the probability of contaminants coming into contact with the sensor. Dust and other particles as well as liquids can affect the RH reading. It is recommended that a cover is employed in the end system that blocks contaminants but allows water vapor to pass through. Depending on the needs of the application, this can be as simple as plastic or metallic gauze for basic protection against particulates or something more sophisticated such as a hydrophobic membrane providing up to IP67 compliant protection.

The Si7007 may be ordered with a factory-fitted, solder-resistant cover that can be left in place for the lifetime of the product. It is very low-profile, hydrophobic and oleophobic. See Section “7. Ordering Guide” for a list of ordering part numbers that include the cover. A dimensioned drawing of the IC with the cover is included in Section “8. Package Outline” . Other characteristics of the cover are listed in Table 9.

Table 9. Specifications of Protective Cover

| Parameter | Value |
|----------------------------|---------------|
| Material | PTFE |
| Operating Temperature | -40 to 125 °C |
| Maximum Reflow Temperature | 260 °C |
| IP Rating (per IEC 529) | IP67 |

4.6. Bake/Hydrate Procedure

After exposure to extremes of temperature and/or humidity for prolonged periods, the polymer sensor film can become either very dry or very wet, in each case the result is either high or low relative humidity readings. Under normal operating conditions, the induced error will diminish over time. From a very dry condition, such as after shipment and soldering, the error will diminish over a few days at typical controlled ambient conditions, e.g., 48 hours of $45 \leq \%RH \leq 55$. However, from a very wet condition, recovery may take significantly longer. To accelerate recovery from a wet condition, a bake and hydrate cycle can be implemented. This operation consists of the following steps:

- Baking the sensor at 125 °C for ≥ 12 hours
- Hydration at 30 °C in 75% RH for ≥ 10 hours

Following this cycle, the sensor will return to normal operation in typical ambient conditions after a few days.

4.7. Long Term Drift/Aging

Over long periods of time, the sensor readings may drift due to aging of the device. Standard accelerated life testing of the Si7007 has resulted in the specifications for long-term drift shown in Table 4 and Table 5. This contribution to the overall sensor accuracy accounts only for the long-term aging of the device in an otherwise benign operating environment and does not include the effects of damage, contamination, or exposure to extreme environmental conditions.

5. PWM Output

During operation, the Si7007 takes a relative humidity and temperature measurement once per second and converts the result into a pulse width modulated waveform. Two output pins are available for reading the measurement results: PWM1 and PWM2. The information output on each pin is determined by the SELECT pin as follows:

Table 10. PWM Outputs

| Voltage on SELECT Pin | PWM1 Output | PWM2 Output |
|-----------------------|-------------|-------------|
| High | RH | Temperature |
| Low | Temperature | RH |

The duty cycle of the waveform on the PWM outputs corresponds to the relative humidity and temperature results shown in the following equations. The PWM duty cycle varies linearly with the measurement result between the minimum and maximum values:

$$RH = -6 + 125 \cdot DC_{PWM}$$

Equation 1.

$$\text{Temperature} = -46.85 + 175.72 \cdot DC_{PWM}$$

Equation 2.

In the typical application, the PWM output is filtered using an RC network to provide an analog output voltage that varies linearly with RH and temperature. See Section “2. Typical Application Circuits” for the recommended application circuit.

Due to normal variations in RH accuracy of the device as described in Table 4, it is possible for the measured value of %RH to be slightly less than 0 when the actual RH level is close to or equal to 0. Similarly, the measured value of %RH may be slightly greater than 100 when the actual RH level is close to or equal to 100. This is expected behavior.

6. Pin Descriptions: Si7007 (Top View)

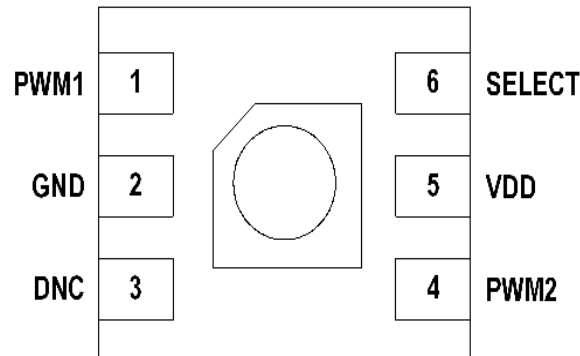

| Pin Name | Pin # | Pin Description |
|------------------|--------|---|
| PWM1 | 1 | Pulse width modulated output #1 |
| GND | 2 | Ground. This pin is connected to ground on the circuit board through a trace. Do not connect directly to GND plane. |
| DNC | 3 | This pin should be soldered to pads on the PCB for mechanical stability. It can be electrically floating or tied to VDD (do not tie to GND). |
| PWM2 | 4 | Pulse width modulated output #2 |
| VDD | 5 | Power. This pin is connected to power on the circuit board. |
| SELECT | 6 | Digital input that toggles between RH and temperature outputs on PWM1 and PWM2. This pin should be pulled high or low (do not leave floating). |
| T _{GND} | Paddle | This pad is connected to GND internally. This pad is the main thermal input to the on-chip temperature sensor. The paddle should be soldered to a floating pad. |

Si7007-A10

7. Ordering Guide

Table 11. Device Ordering Guide

| P/N | Description | Max. Accuracy | | Pkg | Operating Range (°C) | Protective Cover | Packing Format |
|-----------------|--|---------------|------|-------|----------------------|------------------|----------------|
| | | Temp | RH | | | | |
| Si7007-A10-IM | Digital temperature/ humidity sensor—industrial temp range | ±0.4 °C | ± 3% | DFN 6 | –40 to +125 °C | N | Tube |
| Si7007-A10-IMR | Digital temperature/ humidity sensor—industrial temp range | ±0.4 °C | ± 3% | DFN 6 | –40 to +125 °C | N | Tape & Reel |
| Si7007-A10-IM1 | Digital temperature/ humidity sensor—industrial temp range | ±0.4 °C | ± 3% | DFN 6 | –40 to +125 °C | Y | Cut Tape |
| Si7007-A10-IM1R | Digital temperature/ humidity sensor—industrial temp range | ±0.4 °C | ± 3% | DFN 6 | –40 to +125 °C | Y | Tape & Reel |

Note: The “A” denotes product revision A and “10” denotes firmware version 1.0.

8. Package Outline

8.1. Package Outline: 3x3 6-pin DFN

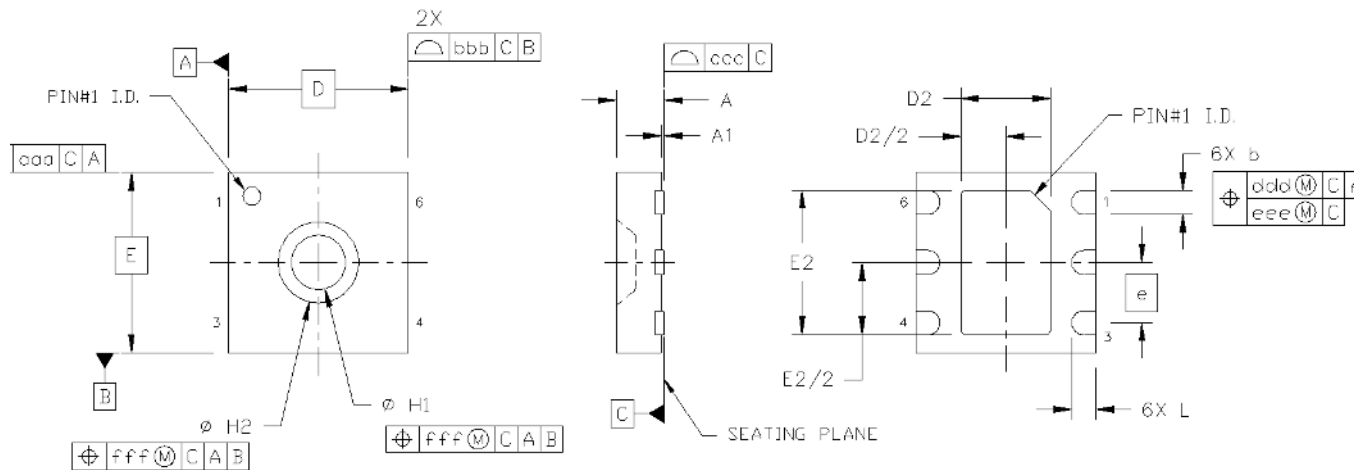

Figure 10. 3x3 6-pin DFN

Table 12. 3x3 6-pin DFN Package Diagram Dimensions

| Dimension | Min | Nom | Max |
|---|-----------|------|------|
| A | 0.70 | 0.75 | 0.80 |
| A1 | 0.00 | 0.02 | 0.05 |
| b | 0.35 | 0.40 | 0.45 |
| D | 3.00 BSC. | | |
| D2 | 1.40 | 1.50 | 1.60 |
| e | 1.00 BSC. | | |
| E | 3.00 BSC. | | |
| E2 | 2.30 | 2.40 | 2.50 |
| H1 | 0.85 | 0.90 | 0.95 |
| H2 | 1.39 | 1.44 | 1.49 |
| L | 0.35 | 0.40 | 0.45 |
| aaa | 0.10 | | |
| bbb | 0.10 | | |
| ccc | 0.05 | | |
| ddd | 0.10 | | |
| eee | 0.05 | | |
| fff | 0.05 | | |
| Notes: | | | |
| 1. All dimensions shown are in millimeters (mm). | | | |
| 2. Dimensioning and Tolerancing per ANSI Y14.5M-1994. | | | |

Si7007-A10

8.2. Package Outline: 3x3 6-pin DFN with Protective Cover

Figure 8 illustrates the package details for the Si7007 with the optional protective cover. Table 13 lists the values for the dimensions shown in the illustration.

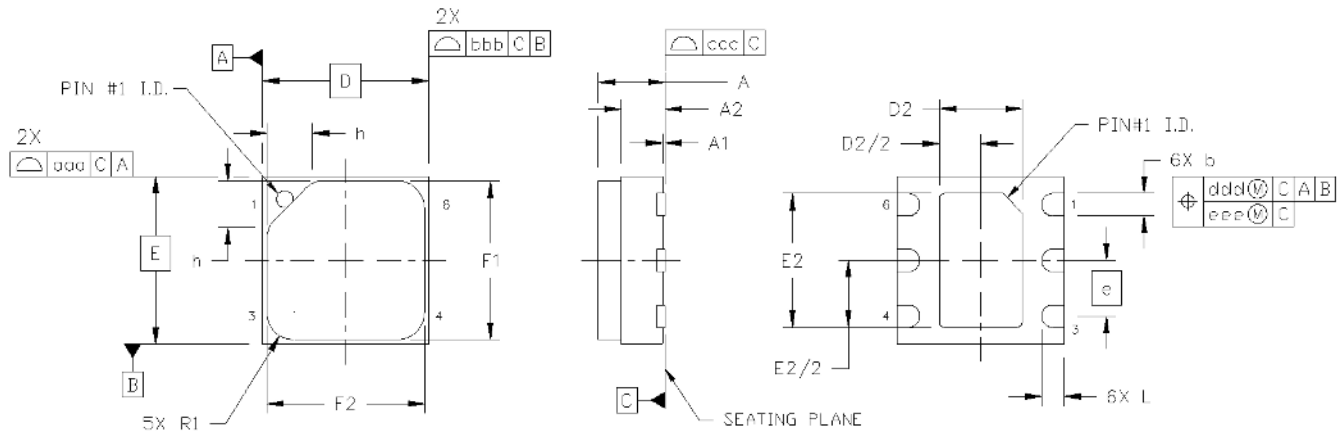

Figure 8. 3x3 6-pin DFN with Protective Cover

Table 13. 3x3 6-pin DFN with Protective Cover Package Diagram Dimensions

| Dimension | Min | Nom | Max |
|---|-----------|------|------|
| A | — | — | 1.21 |
| A1 | 0.00 | 0.02 | 0.05 |
| A2 | 0.70 | 0.75 | 0.80 |
| b | 0.35 | 0.40 | 0.45 |
| D | 3.00 BSC. | | |
| D2 | 1.40 | 1.50 | 1.60 |
| e | 1.00 BSC. | | |
| E | 3.00 BSC. | | |
| E2 | 2.30 | 2.40 | 2.50 |
| F1 | 2.70 | 2.80 | 2.90 |
| F2 | 2.70 | 2.80 | 2.90 |
| h | 0.76 | 0.83 | 0.90 |
| L | 0.35 | 0.40 | 0.45 |
| R1 | 0.45 | 0.50 | 0.55 |
| aaa | 0.10 | | |
| bbb | 0.10 | | |
| ccc | 0.05 | | |
| ddd | 0.10 | | |
| eee | 0.05 | | |
| Notes: | | | |
| 1. All dimensions are shown in millimeters (mm). | | | |
| 2. Dimensioning and Tolerancing per ANSI Y14.5M-1994. | | | |

9. PCB Land Pattern and Solder Mask Design

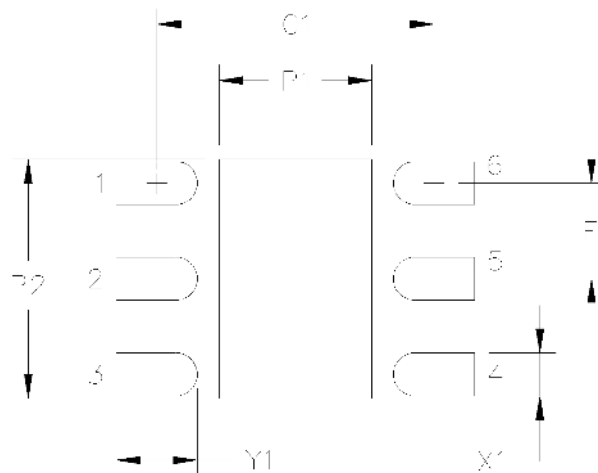

Figure 9. Si7007 PCB Land Pattern

Table 14. PCB Land Pattern Dimensions

| Symbol | mm |
|--------|------|
| C1 | 2.90 |
| E | 1.00 |
| P1 | 1.60 |
| P2 | 2.50 |
| X1 | 0.45 |
| Y1 | 0.85 |

Notes:

General

1. All dimensions shown are at Maximum Material Condition (MMC). Least Material Condition (LMC) is calculated based on a Fabrication Allowance of 0.05 mm.
2. This Land Pattern Design is based on the IPC-7351 guidelines.

Solder Mask Design

3. All metal pads are to be non-solder mask defined (NSMD). Clearance between the solder mask and the metal pad is to be 60 μm minimum, all the way around the pad.

Stencil Design

4. A stainless steel, laser-cut and electro-polished stencil with trapezoidal walls should be used to assure good solder paste release.
5. The stencil thickness should be 0.125 mm (5 mils).
6. The ratio of stencil aperture to land pad size should be 1:1 for all perimeter pins.
7. A 2x1 array of 1.00 mm square openings on 1.30 mm pitch should be used for the center ground pad to achieve a target solder coverage of 50%.

Card Assembly

8. A No-Clean, Type-3 solder paste is recommended.
9. The recommended card reflow profile is per the JEDEC/IPC J-STD-020 specification for Small Body Components.

Si7007-A10

10. Top Marking

10.1. Si7007 Top Marking

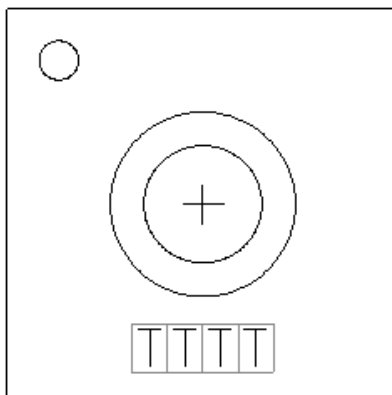

10.2. Top Marking Explanation

| | |
|-------------------------|--|
| Mark Method: | Laser |
| Font Size: | 0.30 mm |
| Pin 1 Indicator: | Circle = 0.30 mm Diameter Upper-Left Corner |
| Line 1 Marking: | TTTT = Mfg Code |

11. Additional Reference Resources

- AN607: Si70xx Humidity Sensor Designer's Guide

DOCUMENT CHANGE LIST

Revision 0.9 to Revision 0.91

- Modified pin numbering on page 1, in Figure 4, and in Section 6.

Revision 0.91 to Revision 1.0

- Updated Table 2, “General Specifications,” on page 4.
- Updated Table 3, “PWM Interface Specifications,” on page 5.
- Updated Table 4, “Humidity Sensor,” on page 6.

Revision 1.0 to Revision 1.1

- Updated features on front page.
- Updated Table 4.
- Updated Figure 2.
- Updated Section “4.5. Protecting the Sensor” .
- Updated Table 9.
- Updated Table 13, dimensions F1 and F2.

CONTACT INFORMATION

Silicon Laboratories Inc.

400 West Cesar Chavez
Austin, TX 78701
Tel: 1+(512) 416-8500
Fax: 1+(512) 416-9669
Toll Free: 1+(877) 444-3032

Please visit the Silicon Labs Technical Support web page:

<http://www.siliconlabs.com/support/pages/contacttechnicalsupport.aspx>
and register to submit a technical support request.

Patent Notice

Silicon Labs invests in research and development to help our customers differentiate in the market with innovative low-power, small size, analog-intensive mixed-signal solutions. Silicon Labs' extensive patent portfolio is a testament to our unique approach and world-class engineering team.

The information in this document is believed to be accurate in all respects at the time of publication but is subject to change without notice. Silicon Laboratories assumes no responsibility for errors and omissions, and disclaims responsibility for any consequences resulting from the use of information included herein. Additionally, Silicon Laboratories assumes no responsibility for the functioning of undescribed features or parameters. Silicon Laboratories reserves the right to make changes without further notice. Silicon Laboratories makes no warranty, representation or guarantee regarding the suitability of its products for any particular purpose, nor does Silicon Laboratories assume any liability arising out of the application or use of any product or circuit, and specifically disclaims any and all liability, including without limitation consequential or incidental damages. Silicon Laboratories products are not designed, intended, or authorized for use in applications intended to support or sustain life, or for any other application in which the failure of the Silicon Laboratories product could create a situation where personal injury or death may occur. Should Buyer purchase or use Silicon Laboratories products for any such unintended or unauthorized application, Buyer shall indemnify and hold Silicon Laboratories harmless against all claims and damages.

Silicon Laboratories and Silicon Labs are trademarks of Silicon Laboratories Inc.
Other products or brandnames mentioned herein are trademarks or registered trademarks of their respective holders.