

ITEM NUMBER	INTERNAL THREAD	EXTERNAL THREAD	MATERIAL
71781-1000	#4-40 UNC-2B	#4-40 UNC-2A	STAINLESS STEEL 303
71781-2000	#4-40 UNC-2B	#4-40 UNC-2A	STAINLESS STEEL 303

NOTES:  
1. PARTS TO BE BULK PACKAGED IN BAGS OF 1,000.

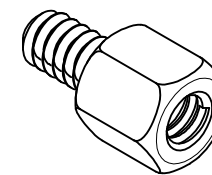

71781-1000

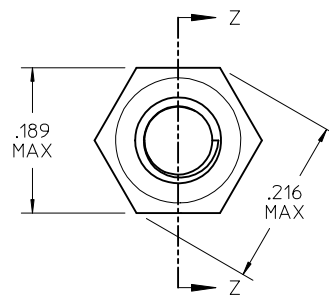
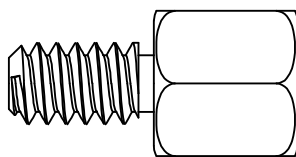
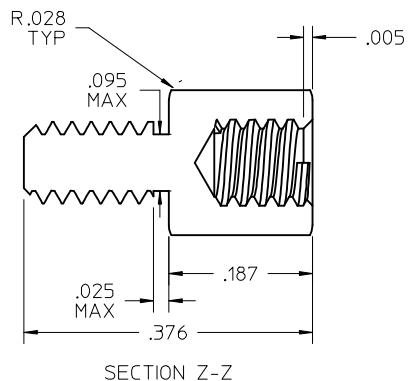
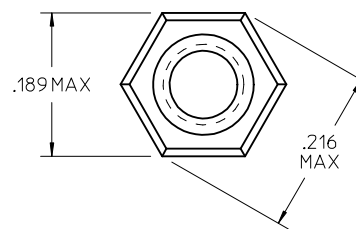
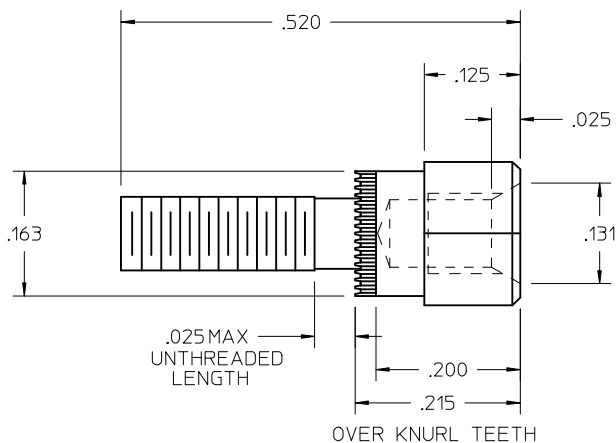
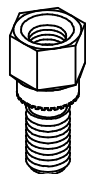

71781-2000  
(SELF CLINCHING STYLE)

<b>MANAGE VIEWS</b> EC NO: UCP2015-3736 DRAWN: TIBARRA 2015/03/12 CHKD: MCAIN 2015/05/05 APPR: SMILLER 2015/05/13	QUALITY SYMBOLS ∇=0 ∇=0 ∇=0	GENERAL TOLERANCES (UNLESS SPECIFIED)		DIMENSION STYLE <b>INCH ONLY</b>		SCALE <b>8:1</b>	DESIGN UNITS <b>INCH</b>	THIRD ANGLE PROJECTION		
		4 PLACES ± --- ± ---	mm	INCH	DRAWN BY	DATE	<b>3/16 HEX JACKPOSTS INT/EXT #4-40 THREAD</b>			
		3 PLACES ± --- ± .005			TIBARRA	2014/08/01				
		2 PLACES ± --- ± ---			CHECKED BY	DATE	<b>molex</b>			
1 PLACE ± --- ± ---			MPOFF	2014/08/29						
0 PLACE ± ±			APPROVED BY	DATE	DOCUMENT NO. <b>SD-71781-1000</b>		SHEET NO. <b>1 OF 1</b>			
		ANGULAR ±1/2°		MATERIAL NO. <b>SEE TABLE</b>						
		DRAFT WHERE APPLICABLE MUST REMAIN WITHIN DIMENSIONS		SIZE <b>C</b>		THIS DRAWING CONTAINS INFORMATION THAT IS PROPRIETARY TO MOLEX INCORPORATED AND SHOULD NOT BE USED WITHOUT WRITTEN PERMISSION				