

## Specification

### Small Form Factor Pluggable

Duplex LC Receptacle – SFP+

### Optical Transceivers

10 Gigabit Ethernet

10GBASE-ZR/ZW



## Ordering Information

**TAS-A1NL1-Q11**

Voltage / Temperature

1. 3.3V / +0°C ~ +70°C

Model Name	Voltage	Category	Device type	Interface	LOS	Temperature	Distance	Latch Color
TAS-A1NL1-Q11	3.3V	With DDMI	1550 nm EML	AC/AC	LVTTTL	0°C~ +70°C	80Km	White <input type="text"/>

## Features

- Compliant to SFF-8431 specifications for enhanced 8.5 and 10 Gigabit small form factor pluggable module “SFP+”
- 1550nm cooled EML transmitter with TEC, APD photo-detector
- 2-Wire Interface for Management Specifications Compliant with SFF 8472 Digital Diagnostic Monitoring Interface for Optical Transceivers
- Operating Case Temperature: 0 to 70 °C
- All-Metal Housing for Superior EMI Performance
- Low power consumption, less than 1.8w
- Advanced Firmware Allow Customer System Encryption Information to Be Stored in Transceiver
- Cost Effective SFP+ Solution, Enables Higher Port Densities and Greater Bandwidth
- ROHS compliant

## Applications

- 10GBASE-ZR/ZW
- 10GBASE-ZR/ZW + FEC
- 10G Storage system

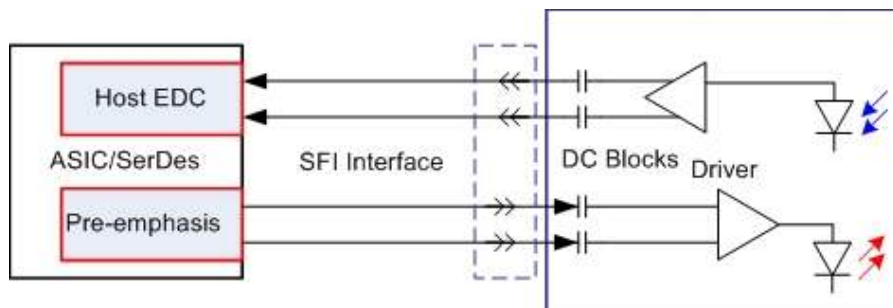

Figure1: Application in System

## **General Description**

This 1550nm cooled EML laser based 10Gigabit SFP+ transceiver is designed to transmit and receive optical data over single mode optical fiber for link length up to 80km.

The SFP+ ZR module electrical interface is compliant to SFI electrical specifications. The transmitter input and receiver output impedance is 100 Ohms differential. Data lines are internally AC coupled. The module provides differential termination and reduce differential to common mode conversion for quality signal termination and low EMI. SFI typically operates over 200 mm of improved FR4 material or up to about 150mm of standard FR4 with one connector.

The transmitter converts 10Gbit/s serial PECL or CML electrical data into serial optical data compliant with the 10GBASE-ZR standard. An open collector compatible Transmit Disable (Tx\_Dis) is provided. A logic "1," or no connection on this pin will disable the laser from transmitting. A logic "0" on this pin provides normal operation. The transmitter has an internal automatic power control loop (APC) to ensure constant optical power output across supply voltage and temperature variations. An open collector compatible Transmit Fault (Tx\_Fault) is provided. TX\_Fault is a module output contact that when high, indicates that the module transmitter has detected a fault condition related to laser operation or safety. The TX\_Fault output contact is an open drain/collector and shall be pulled up to the Vcc\_Host in the host with a resistor in the range 4.7-10 kΩ. TX\_Disable is a module input contact. When TX\_Disable is asserted high or left open, the SFP+ module transmitter output shall be turned off. This contact shall be pulled up to VccT with a 4.7 kΩ to 10 kΩ resistor

The receiver converts 10Gbit/s serial optical data into serial PECL/CML electrical data. An open collector compatible Loss of Signal is provided. Rx\_LOS when high indicates an optical signal level below that specified in the relevant standard. The Rx\_LOS contact is an open drain/collector output and shall be pulled up to Vcc\_Host in the host with a resistor in the range 4.7-10 kΩ, or with an active termination. Power supply filtering is recommended for both the transmitter and receiver. The Rx\_LOS signal is intended as a preliminary indication to the system in which the SFP+ is installed that the received signal strength is below the specified range. Such an indication typically points to non-installed cables, broken cables, or a disabled, failing or a powered off transmitter at the far end of the cable.

Proposed Applications Schematics

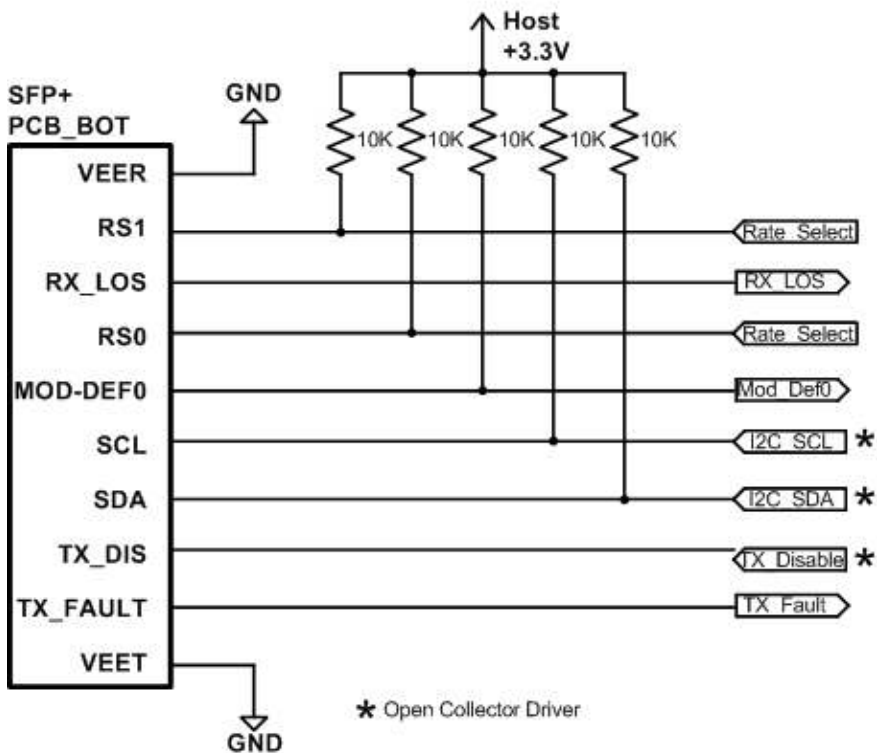
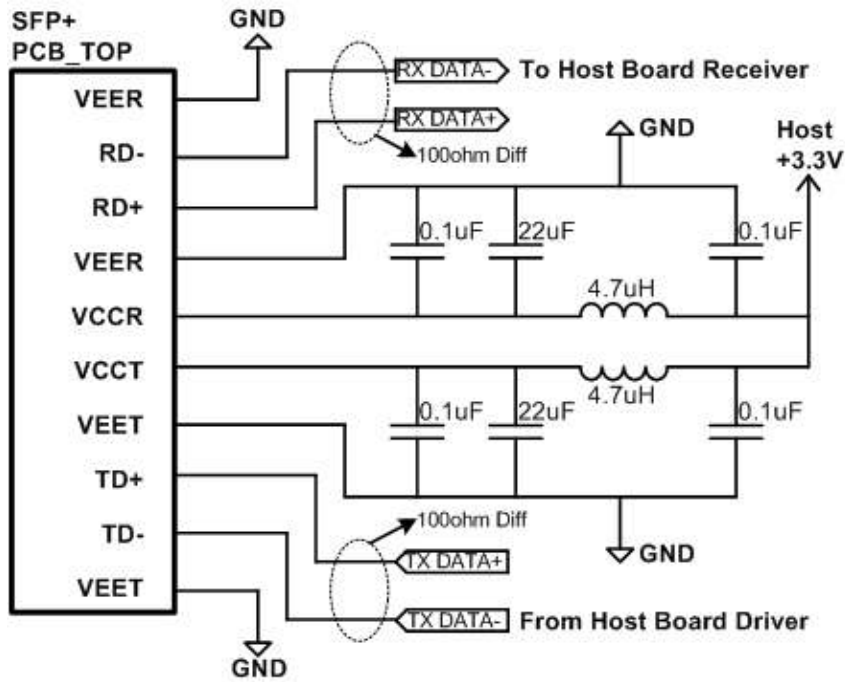

### Pin Definition and Descriptions

The SFP+ modules are hot-pluggable. Hot pluggable refers to plugging in or unplugging a module while the host board is powered. The SFP+ host connector is a 0.8 mm pitch 20 position right angle improved connector specified by SFF-8083, or stacked connector with equivalent with equivalent electrical performance. Host PCB contact assignment is shown in Figure 2 and contact definitions are given in Table 2. SFP+ module contacts mates with the host in the order of ground, power, followed by signal as illustrated by Figure 3 and the contact sequence order listed in the PIN description table.

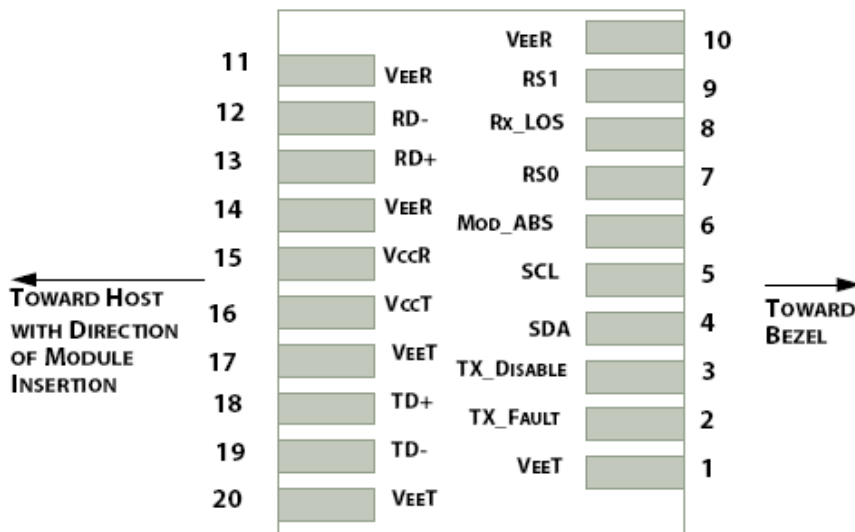

Figure 2: Module Interface to Host

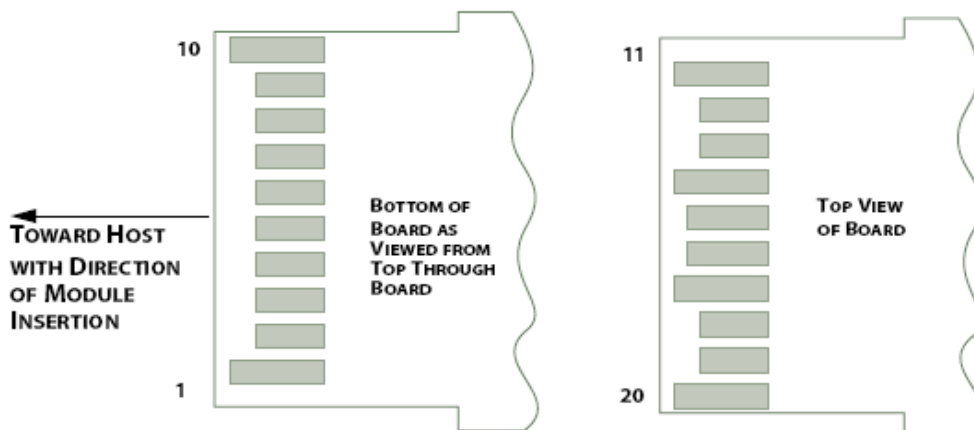

Figure 3: Module Contact Assignment

PIN	Logic	Symbol	Name / Description	Note
1		VeeT	Module Transmitter Ground	1
2	LVTTL-O	TX_Fault	Module Transmitter Fault	3
3	LVTTL-I	TX_Dis	Transmitter Disable; Turns off transmitter laser output	4
4	LVTTL-I/O	SDA	2-Wire Serial Interface Data Line	2
5	LVTTL-I	SCL	2-Wire Serial Interface Clock	2
6		MOD_ABS	Module Absent, Grounded in the module	
7	LVTTL-I	RS0	Receiver Rate Select-Not used	
8	LVTTL-O	RX_LOS	Receiver Loss of Signal Indication Active LOW	3
9	LVTTL-I	RS1	Transmitter Rate Select-Not used	
10		VeeR	Module Receiver Ground	1
11		VeeR	Module Receiver Ground	1
12	CML-O	RD-	Receiver Inverted Data Output	
13	CML-O	RD+	Receiver Data Output	
14		VeeR	Module Receiver Ground	1
15		VccR	Module Receiver 3.3 V Supply	
16		VccT	Module Receiver 3.3 V Supply	
17		VeeT	Module Transmitter Ground	1
18	CML-I	TD+	Transmitter Non-Inverted Data Input	
19	CML-I	TD-	Transmitter Inverted Data Input	
20		VeeT	Module Transmitter Ground	1

**Table 1: SFP+ Module PIN Definition**

**Note:**

1. Module ground pins GND are isolated from the module case.
2. Shall be pulled up with 4.7K-10 kΩ to a voltage between 3.15V and 3.45V on the host board.
3. This contact is an open collector/drain output contact and shall be pulled up on the host board.
4. Tx\_Disable is an input contact with a 4.7 kΩ to 10 kΩ pull up to VccT inside the module.

### Transceiver Block Diagram

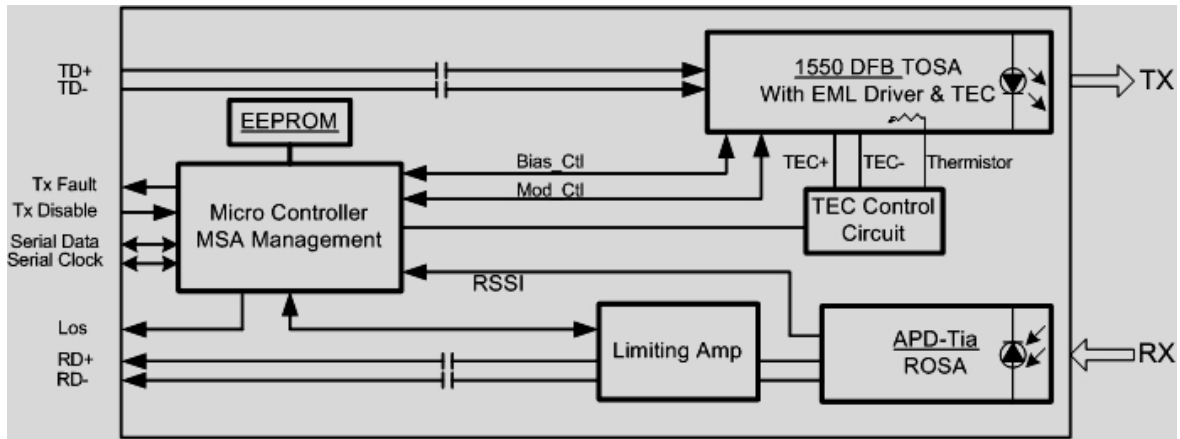

### Absolute Maximum Ratings

These values represent the damage threshold of the module. Stress in excess of any of the individual Absolute Maximum Ratings can cause immediate catastrophic damage to the module even if all other parameters are within Recommended Operating Conditions.

Parameters	Symbol	Min.	Max.	Unit
Power Supply Voltage	V <sub>CC</sub>	0	3.6	V
Storage Temperature	T <sub>c</sub>	-40	85	°C
Operating Case Temperature	T <sub>c</sub>	0	70	°C
Relative Humidity	RH	5	95	%
RX Input Average Power	P <sub>max</sub>	-	-1	dBm

Table 2: Absolute Maximum Rating

## Recommended Operating Environment

Recommended Operating Environment specifies parameters for which the electrical and optical characteristics hold unless otherwise noted.

Parameters	Symbol	Min.	Typical	Max	Unit
Power Supply Voltage	$V_{CC}$	3.135	3.3	3.465	V
Power Supply Currwnt	$I_{CC}$		400	520	mA
Operating Case Temperature	$T_C$	0	25	70	°C

Table 3: Recommended Operating Environment



## Optical Characteristics

The following optical characteristics are defined over the Recommended Operating Environment unless otherwise specified.

Parameters	Unit	Values
Operating Reach(SMF)	km	80
<b>Transmitter</b>		
Center wavelength (range)	nm	1530 -1565
Side Mode Suppression Ratio (min)	dB	30
Launched power		
– maximum (Average)	dBm	4.0
– minimum (Average)	dBm	0
OMA(Minimum)	dBm	-2.1
Transmitter and dispersion penalty (max)(note 3)	dB	3.0
Average launch power of OFF transmitter (max)	dBm	-30
Extinction ratio (min)	dB	9
RIN <sub>12</sub> OMA (max)	dB/Hz	-128
Optical Return Loss Tolerance (min)	dB	21
<b>Receiver</b>		
Center wavelength (range)	nm	1260-1620
Receive overload (max) in average power(note 1)	dBm	-7.0
Receive sensitivity (min) in average power(note 1)	dBm	-24.0
Receiver Reflectance (max)	dBm	-26
LOS Assert(min)	dBm	-40
Los Dessert(max)	dBm	-24
Los Hysteresis(min)	dB	0.5
Stressed eye jitter (min)(note 2)	Ulp-p	0.3
Receive electrical 3dB upper cutoff frequency (max)	GHz	12.3
Receiver power (damage, Max)	dBm	1.0

**Table 4: Optical Characteristics**

**Note:**

1. Average optical power shall be measured using the methods specified in TIA/EIA-455-95.
2. Receiver sensitivity is informative. Stressed receiver sensitivity shall be measured with conformance test signal for BER = $1 \times 10^{-12}$ .
3. Path penalty is intended as the power penalty of the interface between back-to-back and the maximum applied dispersion.

### Digital Diagnostic Functions

The following digital diagnostic characteristics are defined over the Recommended Operating Environment unless otherwise specified. It is compliant to SFF8472 Rev10.2 with internal calibration mode. For external calibration mode please contact our sales staff.

Parameter	Symbol	Min.	Max	Unit	Notes
Temperature monitor absolute error	DMI_Temp	-3.0	3.0	degC	Over operating temp
Laser power monitor absolute error	DMI_TX	-3.0	3.0	dB	
RX power monitor absolute error	DMI_RX	-3	3	dB	-7dBm to -24dBm range
Supply voltage monitor absolute error	DMI_VCC	-0.1	0.1	V	Full operating range
Bias current monitor	DMI_Ibias	-10%	10%	mA	

**Table 5: Digital diagnostic specification table**

### Electrical Characteristics

The following electrical characteristics are defined over the Recommended Operating Environment unless otherwise specified.

Parameter	Symbol	Min.	Typical	Max	Unit	Notes
Data Rate		-	10.3125	11.3	Gbps	
Power Consumption		-	1200	1800	mW	
<b>Transmitter</b>						
Single Ended Output Voltage Tolerance		-0.3	-	4	V	
C common mode voltage tolerance		15	-	-	mV	
Tx Input Diff Voltage	VI	180		700	mV	
Tx Fault	VoL	-0.3		0.4	V	
	Voh	2.0		Vcc+0.3	V	
Tx Disable	VoL	Vee		Vee+0.8	V	
	Voh	2		Vcc	V	
Data Dependent Input Jitter	DDJ			0.1	UI	
Data Input Total Jitter	TJ			0.28	UI	
<b>Receiver</b>						
Single Ended Output Voltage Tolerance		-0.3	-	4	V	
Rx Output Diff Voltage	Vo	300		850	mV	
Rx Output Rise and Fall Time	Tr/Tf	30			ps	20% to 80%
Total Jitter	TJ			0.7	UI	
Deterministic Jitter	DJ			0.42	UI	

**Table 6: Electrical Characteristics**

### Control And Status I/O Timing Characteristics

Timing characteristics of control and status I/O are included in Table 9, which is also defined in SFF-8431.

Parameter	Symbol	Min	Max	Unit	Condition
TX Disable Assert Time	t_off		10	μs	Time from rising edge of TX Disable to when the optical output falls below 10% of nominal
TX Disable Negate Time	t_on		1	ms	Time from falling edge of TX Disable to when the modulated optical output rises above 90% of nominal
Time to initialize, including reset of TX_Fault	t_init		300	ms	From power on or negation of TX Fault using TX Disable
TX Fault Assert Time	t_fault		100	μs	Time from fault to TX fault on.
TX Disable to reset	t_reset	10		μs	Time TX Disable must be held high to reset TX_fault
LOS Assert Time	t_loss_on		100	μs	Time from LOS state to RX LOS assert
LOS Deassert Time	t_loss_off		100	μs	Time from non-LOS state to RX LOS deassert
Rate-Select Change Time	t_ratesel		10	μs	Time from rising or falling edge of Rate Select input until receiver bandwidth is in conformance with appropriate specification.
Serial ID Clock Rate	f_serial_clock		100	kHz	

**Table 7: Timing Characteristics**



**Content in 2-Wire Address A0H**

Address	HEX	Name of Field	Description
00	03	Identifier	SFP
01	04	Extended Identifier	SFP
02	07	Connector type	LC
03	80	10G Ethernet Compliance Codes	10G Base ZR
04	00	SONET Compliance Codes	Not compliant
05	00	SONET Compliance Codes	Not compliant
06	00	Ethernet Compliance Codes	Not compliant
07	00	Fiber Channel link length	Not compliant
08	00	Fiber Channel transmitter technology	Not compliant
09	00	Fiber Channel transmission media	Not compliant
10	00	Fiber Channel speed	Not compliant
11	06	Encoding codes:	64B/66B
12	67	Nominal Bit Rate (units of 100Mbps)	10.3Gbps
13	00	Rate identifier	Unspecified
14	50	Link length supported for 9um fiber	80 (units of km)
15	FF	Link length supported for 9um fiber	800 (units of 100m)
16	00	Link length supported for 50um,OM2	N/A (units of 10m)
17	00	Link length supported for 62.5um,OM1	N/A (units of 10m)
18	00	Link length supported for copper	N/A (units of 1m)
19	00	Link length supported for 50um,OM3	N/A (units of 10m)
20 ~ 35	46,4F,52,4D,45,52,49,43,41,4F,45,20,20,20,20,20	Vendor Name	FORMERICA OE
36	00	Unallocated	
37 ~ 39	00,00,00	Vendor IEEE company ID	Unspecified
40 ~ 55	54,41,53,2D,41,31,4E,4C,31,2D,51,31,31,20,20,20	Part Number	TAS-A1NL1-Q11
56 ~ 59	00,00,00,00	Vendor Revision number	Unspecified
60 ~ 61	06,0E	Laser Wavelength	1550nm
62	00	Unallocated	
63		CC_BASE:	Check sum of byte 0 ~ 62
64	00	Options	
65	1A	Options	TX-DIS, TX_FAULT, RX-LOS
66	00	Bit Rate, max.	Unspecified
67	00	Bit Rate, min.	Unspecified
68 ~ 83	Serial Number	Serial Number	
84 ~ 89	yy/mm/dd	Date Code	
90 ~ 91	20,20	Vendor specific lot code	Unspecified
92	68	Diagnostic Monitoring Type	Internal calibration
93	F0	Enhanced Options (soft)	Alarm/Warn thresholds TxDisable,control/monitoring TxFault monitoring LOS
94	04	SFF-8472 Compliance	Unspecified
95		CC_EXT	Check sum of byte 64 ~ 94
96~127		Vendor specific	



Content in 2-Wire Address A2H

Add	Bytes	Name	Hex	Real Value
00-01	2	Temp High Alarm	4E00	78°C
02-03	2	Temp Low Alarm	F800	-8°C
04-05	2	Temp High Warning	4B00	75°C
06-07	2	Temp Low Warning	FB00	-5°C
08-09	2	Voltage High Alarm	9088	3.7V
10-11	2	Voltage Low Alarm	7170	2.9V
12-13	2	Voltage High Warning	8C70	3.5V
14-15	2	Voltage Low Warning	7548	3V
16-17	2	Bias High Alarm	F424	125mA
18-19	2	Bias Low Alarm	1D4C	15mA
20-21	2	Bias High Warning	EA60	120mA
22-23	2	Bias Low Warning	2710	20mA
24-25	2	TX Power High Alarm	7B87	5dBm
26-27	2	TX Power Low Alarm	1394	-3dBm
28-29	2	TX Power High Warning	621F	4dBm
30-31	2	TX Power Low Warning	1F07	-1dBm
32-33	2	RX Power High Alarm	0C5A	-5dBm
34-35	2	RX Power Low Alarm	0019	-26dBm
36-37	2	RX Power High Warning	07CB	-7dBm
38-39	2	RX Power Low Warning	0020	-24dBm
40-55	16	Reserved	FF	-
56-59	4	RX_PWR(4)	00000000	0
60-63	4	RX_PWR(3)	00000000	0
64-67	4	RX_PWR(2)	00000000	0
68-71	4	RX_PWR(1)	3F800000	1
72-75	4	RX_PWR(0)	00000000	0
76-77	2	TX_I(Slope)	0100	1
78-79	2	TX_I(Offset)	0000	0
80-81	2	TX_PWR(Slope)	0100	1
82-83	2	TX_PWR(Offset)	0000	0
84-85	2	T(Slope)	0100	1
86-87	2	T(Offset)	0000	0
88-89	2	V(Slope)	0100	1
90-91	2	V(Offset)	0000	0
92-94	3	Reserved	00	-
95	1	Checksum		-

## Mechanical

Comply to SFF-8432 rev. 5.0, the improved Pluggable form factor specification.

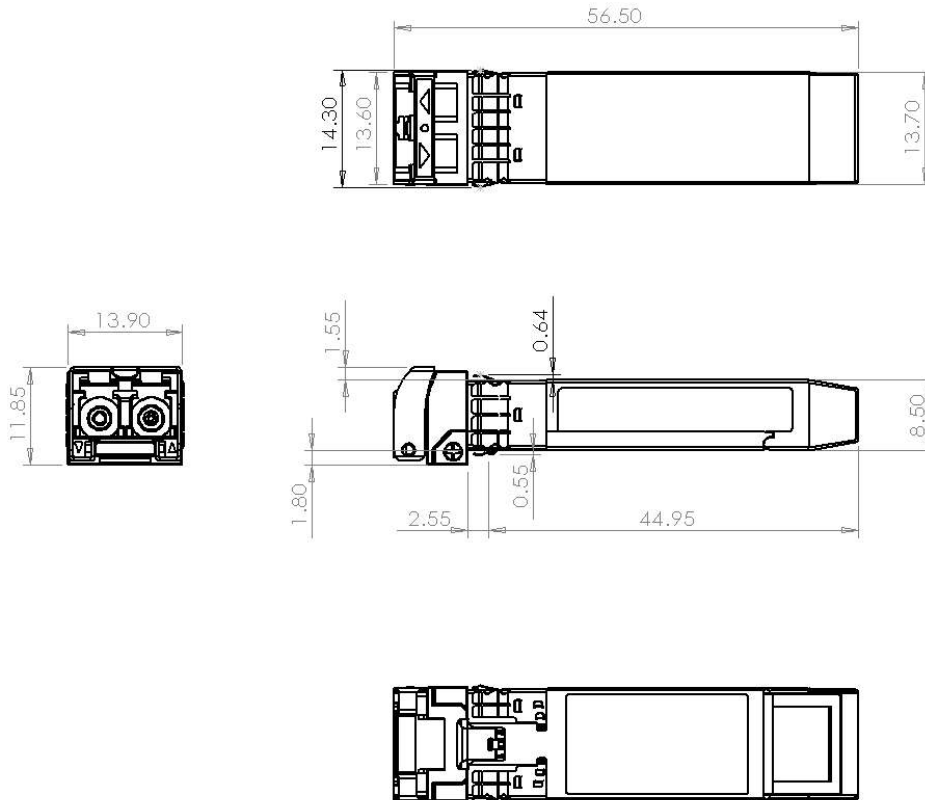

## ESD

This transceiver is specified as ESD threshold 2kV for all electrical input pins, tested per MIL-STD-883, Method 3015.4 /JESD22-A114-A (HBM). However, normal ESD precautions are still required during the handling of this module. This transceiver is shipped in ESD protective packaging. It should be removed from the packaging and handled only in an ESD protected environment.

## LASER Safety

This is a Class 1 Laser Product according to IEC 60825-1:1993:+A1:1997+A2:2001. This product complies with 21 CFR 1040.10 and 1040.11 except for deviations pursuant to Laser Notice No. 50, dated (July 26, 2001)