

PRODUCT NUMBER

71922-YXXZLF

- RoHS COMPATIBLE, SEE NOTE 10
- = STANDARD HOUSING COLOR GREY (WITHOUT OPTIONAL LETTER)
- B= OPTIONAL HOUSING COLOR BLACK
- S= SPECIFIC CUSTOMER PLATING OPTION HOUSING COLOR GREY
- TOTAL NB OF POSITIONS, SEE SHEET 2
- LATCHING
 - 0= WITHOUT LATCH
 - 1= STANDARD LATCH
 - 2= LOW PROFILE LATCH

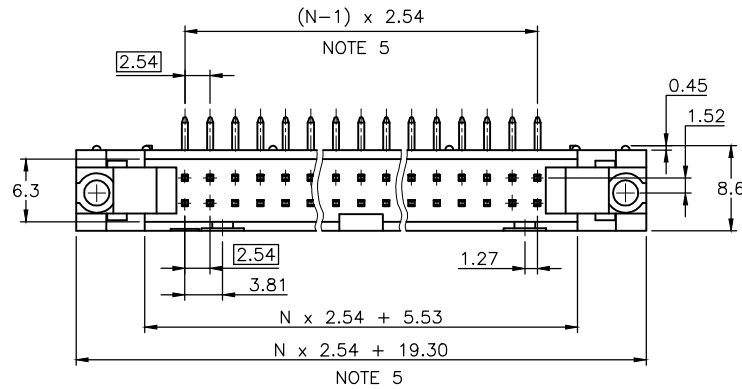

NOTES:

- 1 - HOUSING MAT'L : GLASS FILLED THERMOPLASTIC. UL94V-0
- 2 - PIN MATERIAL : PHOSPHOR BRONZE
- 3 - PRODUCT PACKAGED IN TUBES
- 4 - 40N MIN LATCH RETENTION FORCE AT FIRST EXTRACTION
- 5 - TO DETERMINE DIMENSIONS :
N = NUMBER OF POSITIONS PER ROW
EXAMPLE : 8 POS N x 2.54 = 20.32mm
- 6 - NO CENTRAL SLOT ON POSITIONS 6 & 8
- 7 - NO LEFT POLARIZATION ON POSITIONS 06, 08, 10, 14.
- 8 - NO GROOVE ON POSITIONS 06, 08, 10, 14, 30, 34
- 9 - 4.5mm SOLDER TAIL
ORDER 71922-4XX (WITH STANDARD LATCH ONLY)
ORDER 71922-5XX (WITH LOW PROFILE LATCH ONLY)
- 10 - RoHS COMPATIBLE PRODUCT SPECIFICATIONS

a - PLATING:

- "LF" MEANS THE PRODUCT IS LEAD-FREE, 2µm MINIMUM MATTE TIN OVER 1.27µm MINIMUM NICKEL UNDERPLATE.

b - MANUFACTURING PROCESS COMPATIBILITY

- THE HOUSING WILL WITHSTAND EXPOSURE TO 260°C ±5°C SOLDER BATH TEMPERATURE FOR 5 SECONDS IN A WAVE SOLDER APPLICATION WITH A 1.6mm MIN THICK CIRCUIT BOARD.

c - LABELING:

- MEETS PACKAGING SPECS AS PER GS-14-920

d - LEGAL STATEMENT: SEE GS-47-0004.

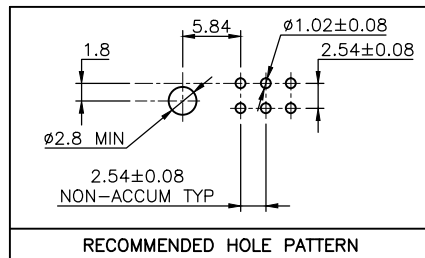
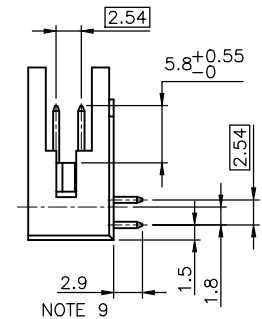
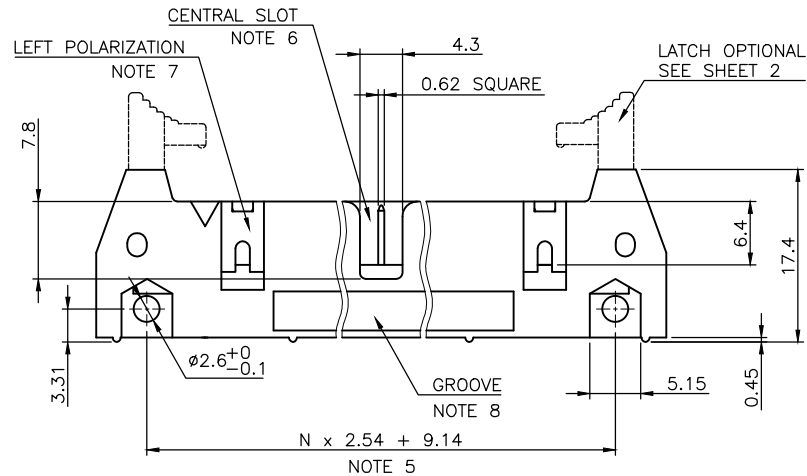

mat'l. code SEE NOTES		surface ISO 1302 ✓	tolerance ISO 406 ISO 1101	projection mm	product family QUICKIE	
ltr	ecn no dr date	tolerances unless otherwise specified			title SHR, EL. HEADER RA DR TMT	
V	F10-0054 LMU 10.05.19	angles	.XX ±0.3			
W	B-16776 LMU 14.01.23	linear	.XX ±0.13	scale 2:1	sheet 1 of 2 size	
X	B-18018 JCO 14.06.19		.XXX ±0.05		71922 A3	
Y	B-18236 LMU 14.07.08	dr	D.LE 01.01.24		type	CUSTOMER Drawing
AA	B-19092 LMU 14.10.16	engr	JM.C 01.01.24			
AB	B-20349 BVE 15.03.02	chr	JF.N 01.01.24			
sheet index		revision	AB T			
1		2				

PRODUCT NUMBER	SIZE	LATCHING AVAILABILITY	MISSING PIN POSITIONS
71922-X06(B)LF	2x3	0/1/2	
71922-X08(B)LF	2x4	0/1/2	
71922-X10(B)LF	2x5	0/1/2	
71922-X14(B)LF	2x7	0/1/2	
71922-X16(B)LF	2x8	0/1/2	
71922-X18(B)LF	2x9	0/1/2	
71922-X20(B)LF	2x10	0/1/2	
71922-X26(B)LF	2x13	0/1/2	
71922-X28(B)LF	2x13	0/1/2	PIN 5 TO 12
71922-X30(B)LF	2x15	0/1/2	
71922-X34(B)LF	2x17	0/1/2	
71922-X35(B)LF	2x17	0/1/2	PIN 2 & 3
71922-X39(B)LF	2x20	0/1/2	PIN 20
71922-X40(B)LF	2x20	0/1/2	
71922-X44(B)LF	2x22	0/1/2	
71922-X50(B)LF	2x25	0/1/2	
71922-X60(B)LF	2x30	0/1/2	
71922-X64(B)LF	2x32	0/1/2	

PLATING :

- 0.76µm GOLD/GXT (PdNi WITH GOLD FLASH) ON CONTACT AREA
- 2µm MIN MATTE TIN ON TAIL
- UNDERPLATE : 1.27µm Ni MIN

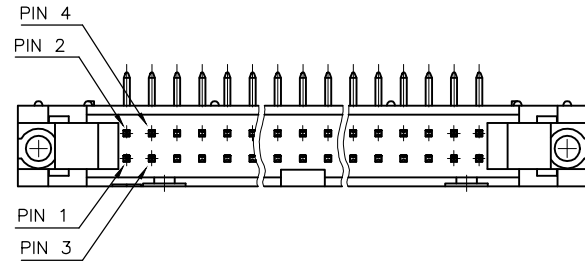

LATCHING FEATURES :

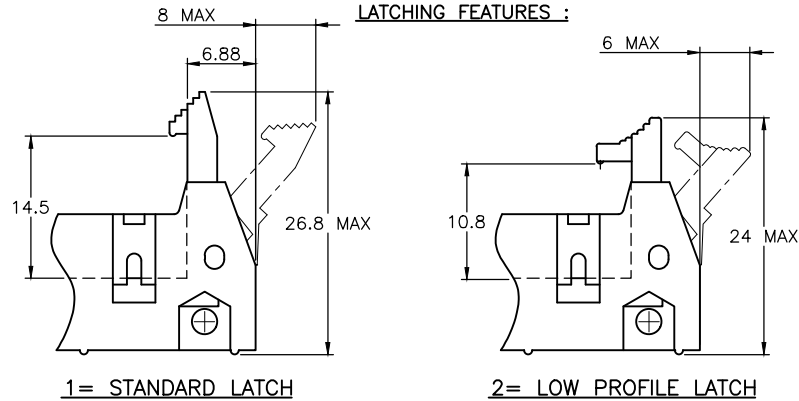

mat'l. code		surface		tolerance		projection		product family	
		ISO 1302		ISO 406		ISO 1101		QUICKIE	
ltr		ecn no		dr		date		title	
M		F06-0229		LMU		06.07.17		SHR.EL.HEADER	
N		F07-0195		LMU		07.05.25		RA DR TMT	
P		F08-0146		YOV		08.04.11		scale 2:1	
R		B-16776		LMU		14.01.23		dr	
S		B-19092		LMU		14.10.16		engr	
T		B-20349		BVE		15.03.02		chr	
								appd	
sheet		revision							
index		sheet							



Copyright FCI