

Precision, High Slew Rate, Wideband Operational Amplifier

March 1993

Features

- High Slew Rate 120V/ μ s
- Low Offset Voltage 300 μ V
- High Open Loop Gain 130dB
- Gain Bandwidth Product 150MHz
- Low Noise Voltage at 1kHz 8.3nV/ $\sqrt{\text{Hz}}$
- Minimum Gain Stability ≥ 5

Applications

- High Speed Instrumentation
- Data Acquisition Systems
- Analog Signal Conditioning
- Precision, Wideband Amplifiers
- Pulse/RF Amplifiers

Description

The HA-2548 is a monolithic op amp that offers a unique combination of bandwidth, slew rate, and precision specifications. These features can eliminate the need for composite op amp designs and external calibration circuitry.

Optimized for gains ≥ 5 , the HA-2548 has a gain-bandwidth product of 150MHz and a slew rate of 120V/ μ s while maintaining extremely high open loop gain (130dB typ) and low offset voltage (300 μ V typ). These specifications are achieved through uniquely designed input circuitry and a single ultra-high gain stage that minimizes the AC signal path. Capable of delivering over 30mA of output current, the HA-2548 is ideal for precision, high speed applications such as signal conditioning, instrumentation, video/pulse amplifiers and buffers.

For information on the military version of this device please refer to the HA-2548/883 datasheet.

Ordering Information

PART NUMBER	TEMPERATURE RANGE	PACKAGE
HA2-2548-5	0°C to +75°C	8 Pin CAN
HA2-2548-9	-40°C to +85°C	8 Pin CAN
HA3-2548-5	0°C to +75°C	8 Lead Plastic DIP
HA7-2548-5	0°C to +75°C	8 Lead Ceramic Sidebrazed DIP
HA7-2548-9	-40°C to +85°C	8 Lead Ceramic Sidebrazed DIP
HA9P2548-5	0°C to +75°C	16 Lead Wide Body SOIC

Pinouts

HA-2548
(PDIP, CDIP)
TOP VIEW

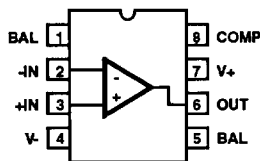

HA-2548
(TO-99 CAN)
TOP VIEW

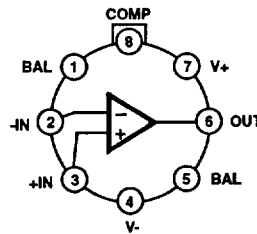

HA-2548
(300 mil SOIC)
TOP VIEW

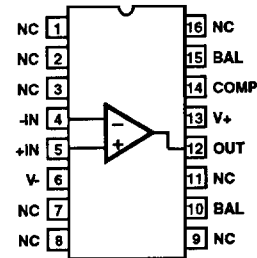

CAUTION: These devices are sensitive to electrostatic discharge. Users should follow proper I.C. Handling Procedures.
Copyright © Harris Corporation 1993

File Number 2901.1

Specifications HA-2548

Absolute Maximum Ratings (Note 1)

Supply Voltage Between V+ and V- Terminals	40V
Differential Input Voltage	5V
Output Current	40mA
Junction Temperature	+175°C
Junction Temperature (Plastic Package)	+150°C
Lead Temperature (Soldering 10 Sec.)	+300°C

Operating Conditions

Operating Temperature Range	
HA-2548-5	0°C ≤ T _A ≤ +75°C
HA-2548-9	-40°C ≤ T _A ≤ +85°C
Storage Temperature Range	-65°C ≤ T _A ≤ +150°C

CAUTION: Stresses above those listed in "Absolute Maximum Ratings" may cause permanent damage to the device. This is a stress only rating and operation of the device at these or any other conditions above those indicated in the operational sections of this specification is not implied.

Electrical Specifications V+ = +15V, V- = -15V, R_L = 1K, C_L = 10pF, Unless Otherwise Specified.

PARAMETER	TEMP	HA-2548-5, -9 LIMITS			HA-2548A-5 LIMITS			UNITS
		MIN	TYP	MAX	MIN	TYP	MAX	
INPUT CHARACTERISTICS								
Input Offset Voltage	+25°C	-	300	900	-	100	300	μV
	Full	-	400	1200	-	200	600	μV
Average Offset Voltage Drift (Note 12)	Full	-	4	9	-	3	7	μV/°C
Input Bias Current	+25°C	-	5	50	-	5	50	nA
	Full	-	20	100	-	20	100	nA
Input Offset Current	+25°C	-	5	50	-	5	50	nA
	Full	-	20	100	-	20	100	nA
Common Mode Range	+25°C	±7	±10	-	±7	±10	-	V
Differential Input Resistance	+25°C	-	1	-	-	1	-	MΩ
Input Noise Voltage (f = 0.1Hz to 10Hz) (f = 0.1Hz to 1MHz)	+25°C	-	0.2	-	-	0.2	-	μVrms
	+25°C	-	0.8	-	-	0.8	-	μVrms
Input Noise Voltage Density (Note 2) (f = 10Hz) (f = 100Hz) (f = 1000Hz)	+25°C	-	30	-	-	30	-	nV/√Hz
	+25°C	-	12	-	-	12	-	nV/√Hz
	+25°C	-	8.3	-	-	8.3	-	nV/√Hz
Input Noise Current Density (Note 2) (f = 10Hz) (f = 100Hz) (f = 1000Hz)	+25°C	-	1.9	-	-	1.9	-	pA/√Hz
	+25°C	-	0.7	-	-	0.7	-	pA/√Hz
	+25°C	-	0.4	-	-	0.4	-	pA/√Hz
TRANSFER CHARACTERISTICS								
Large Signal Voltage Gain (Note 3)	+25°C	114	130	-	120	130	-	dB
	Full	108	125	-	118	125	-	dB
Common Mode Rejection Ratio (Note 4)	Full	80	90	-	80	90	-	dB
Gain Bandwidth Product (Notes 5, 12)	+25°C	130	150	-	130	150	-	MHz
	Full	110	125	-	110	125	-	MHz
Minimum Stable Gain	Full	5	-	-	5	-	-	V/V
OUTPUT CHARACTERISTICS								
Output Voltage Swing	Full	±11	±12	-	±11	±12	-	V
Output Current (Note 6)	Full	±30	±33	-	±30	±33	-	mA
Output Resistance	+25°C	-	5	-	-	5	-	Ω
Full Power Bandwidth (Note 7)	+25°C	-	1.91	-	-	1.91	-	MHz

2
OPERATIONAL
AMPLIFIERS

Specifications HA-2548

Electrical Specifications $V_+ = +15V$, $V_- = -15V$, $R_L = 1K$, $C_L = 10pF$, Unless Otherwise Specified. (Continued)

PARAMETER	TEMP	HA-2548-5, -9 LIMITS			HA-2548A-5 LIMITS			UNITS
		MIN	TYP	MAX	MIN	TYP	MAX	
TRANSIENT RESPONSE								
Slew Rate (Notes 8, 12) Positive	+25°C	80	120	-	80	120	-	V/ μ s
	Full	70	105	-	70	105	-	V/ μ s
Slew Rate (Notes 8, 12) Negative	+25°C	70	110	-	70	110	-	V/ μ s
	Full	60	105	-	60	105	-	V/ μ s
Rise Time (Notes 9, 12)	+25°C	-	16.5	20	-	16.5	20	ns
	Full	-	19	23	-	19	23	ns
Fall Time (Notes 9, 12)	+25°C	-	16	20	-	16	20	ns
	Full	-	18	23	-	18	23	ns
Overshoot (Notes 9, 12) Positive	+25°C	-	15	25	-	15	25	%
	Full	-	25	35	-	25	35	%
Overshoot (Notes 9, 12) Negative	+25°C	-	8	15	-	8	15	%
	Full	-	20	30	-	20	30	%
Settling Time (Notes 10, 12)	+25°C	-	200	260	-	200	260	ns
POWER SUPPLY								
Power Supply Rejection Ratio (Note 11)	Full	86	95	-	86	95	-	dB
I_{CC}	Full	-	12	18	-	12	18	mA

NOTES:

1. Absolute maximum ratings are limiting values, applied individually, beyond which the serviceable of the circuit may be impaired. Functional operation under any of these conditions is not necessarily implied.
2. Refer to typical performance curve in data sheet.
3. $V_{OUT} = \pm 10V$.
4. $V_{CM} = \pm 2V$.
5. Characterized in an $A_V = -100$ configuration from 100kHz to 10MHz.
6. $R_L = 1k\Omega$, $V_{OUT} > 10V$.
7. Full Power Bandwidth is calculated by: $FPBW = \frac{\text{Slew Rate}}{2\pi V_{PEAK}}$, $V_{PEAK} = 10V$
8. $V_{OUT} = \pm 5V$, $A_V = +5$.
9. $V_{OUT} = \pm 100mV$, $A_V = +5$.
10. Settling time is specified to 0.01% with a 10V step and $A_V = -5$.
11. Delta $V_S = \pm 10V$ to $\pm 20V$.
12. These parameters are not tested. The limits are guaranteed based on lab characterization and reflect lot to lot variation.

Schematic Diagram

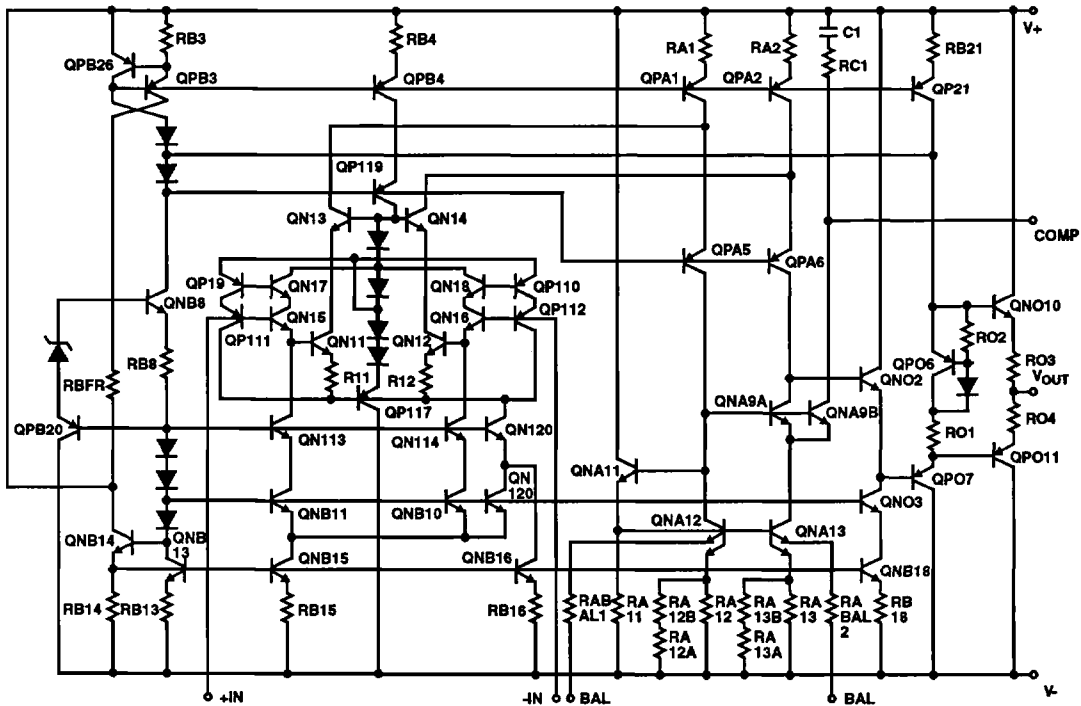

2
OPERATIONAL
AMPLIFIERS

Die Characteristics

Transistor Count	60	
Die Dimensions	85 x 91 x 19 mils (2160 x 2320 x 482µm)	
Substrate Potential*	V-	
Process	High Frequency Bipolar DI	
Metallization:		
Type	Aluminum, 1% Copper	
Thickness	16kÅ ± 2kÅ	
Glassivation:		
Type	Nitride over Silox	
Silox Thickness	12kÅ ± 2kÅ	
Nitride Thickness	3.5kÅ ± 1kÅ	
Thermal Constants (°C/W)	θ _{JA}	θ _{JC}
Sidebrazed Ceramic DIP	75	12
Plastic DIP	92	30
SOIC	96	26
CAN	105	32

* The substrate may be left floating (Insulating Die Mount) or it may be mounted on conductor at V- potential.

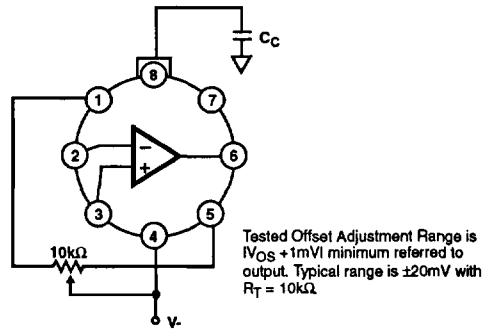
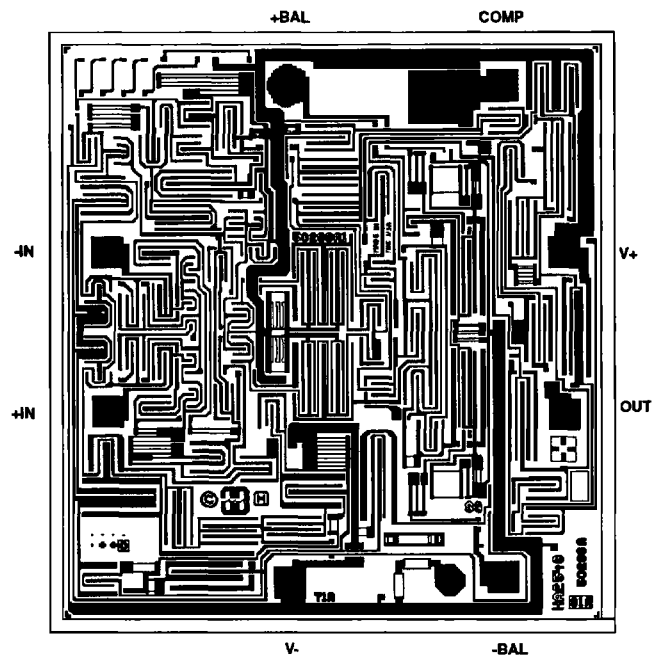

FIGURE 1. SUGGESTED V_{OS} ADJUSTMENT AND COMPENSATION HOOK UP

Metallization Mask Layout

HA-2548



Test Circuits and Waveforms

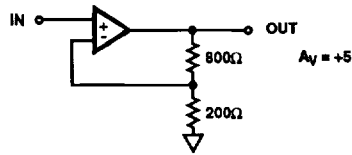

FIGURE 2. LARGE AND SMALL SIGNAL RESPONSE CIRCUIT

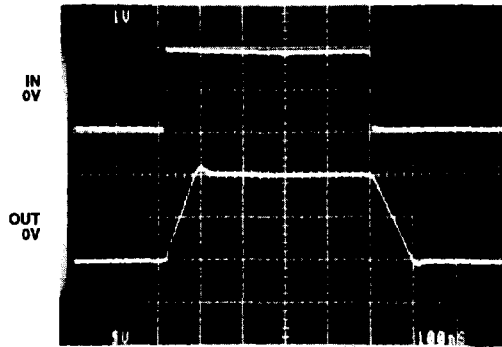

FIGURE 3. LARGE SIGNAL RESPONSE
 $V_{OUT} = \pm 5V$, $A_V = +5$, $R_L = 1K$, $C_L \leq 10pF$

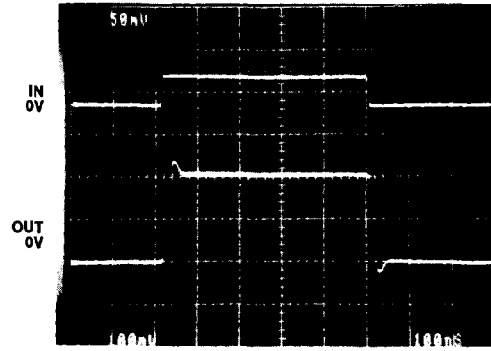
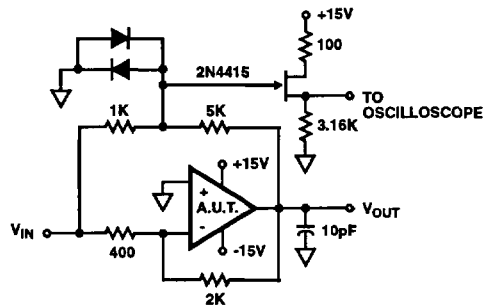

FIGURE 4. SMALL SIGNAL RESPONSE
 $V_{OUT} = \pm 100mV$, $A_V = +5$, $R_L = 1K$, $C_L \leq 10pF$



- $A_V = -5$
- Feedback and summing resistors should be 0.1% matched.
- Clipping diodes are optional. HP5082-2B10 recommended.

FIGURE 5. SETTLING TIME TEST CIRCUIT

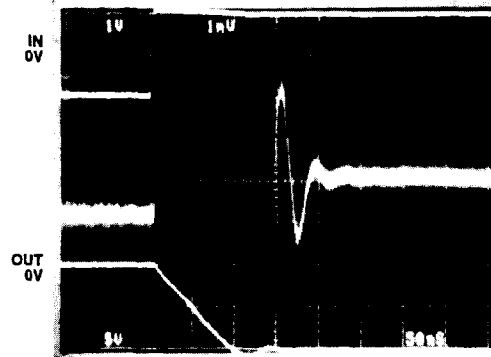

FIGURE 6. HA-2548 SETTLING TIME
 $A_V = -5$, Output = -10V Output Scale Vertical: 1mV/Div,
 Horizontal: 50ns/Div

Typical Performance Curves $V_S = \pm 15V, T_A = +25^\circ C$

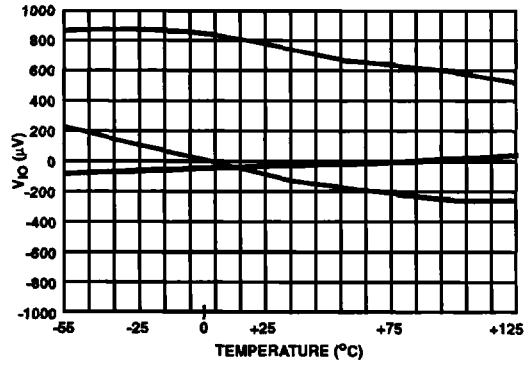

FIGURE 7. V_{IO} vs TEMPERATURE
(3 Representative Units)

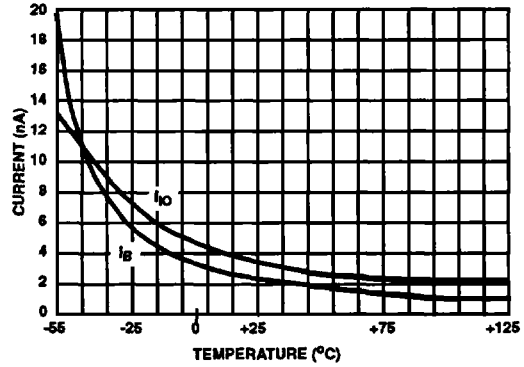

FIGURE 8. OFFSET CURRENT/BIAS CURRENT vs TEMPERATURE

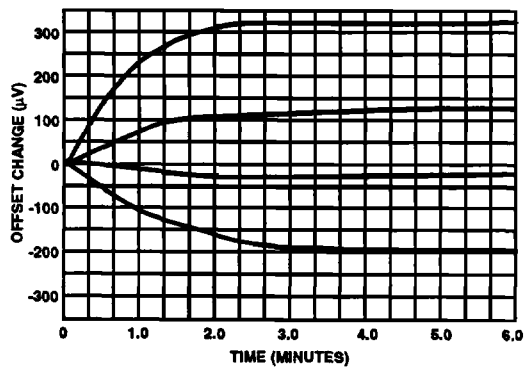

FIGURE 9. V_{IO} WARM-UP DRIFT (NORMALIZED FROM ZERO)
(4 Representative Units)

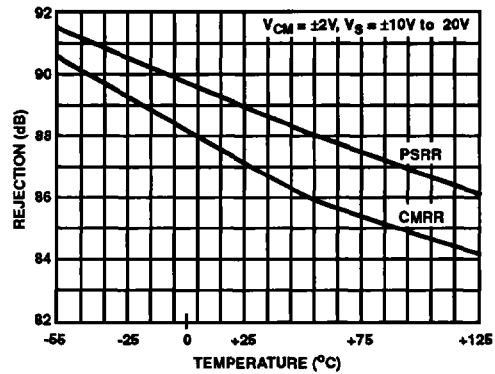

FIGURE 10. PSRR/CMRR vs TEMPERATURE

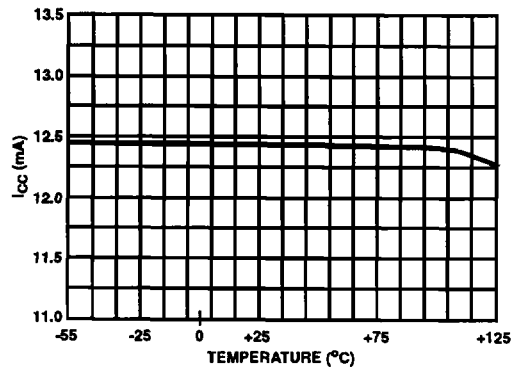

FIGURE 11. I_{CC} vs TEMPERATURE

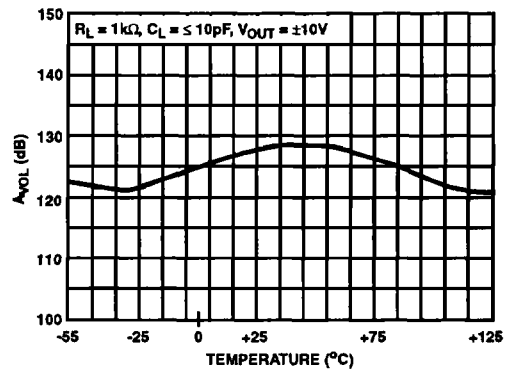

FIGURE 12. A_{VOL} vs TEMPERATURE

Typical Performance Curves $V_S = \pm 15V, T_A = +25^\circ C$ (Continued)

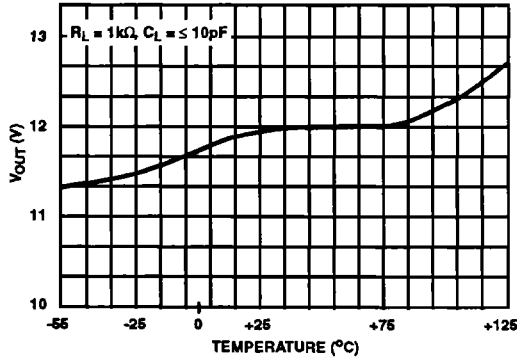

FIGURE 13. V_{OUT} vs TEMPERATURE

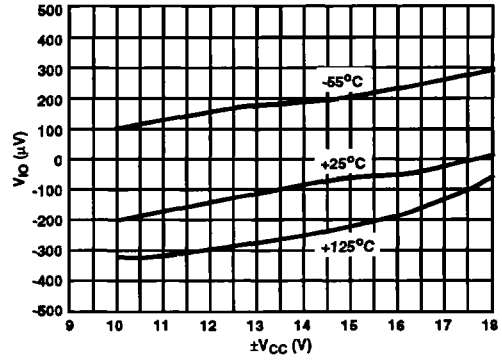

FIGURE 14. V_{IO} vs $\pm V_{CC}$ vs TEMPERATURE

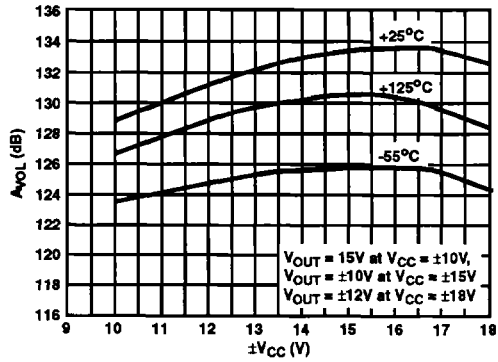

FIGURE 15. A_{VOL} vs $\pm V_{CC}$ vs TEMPERATURE

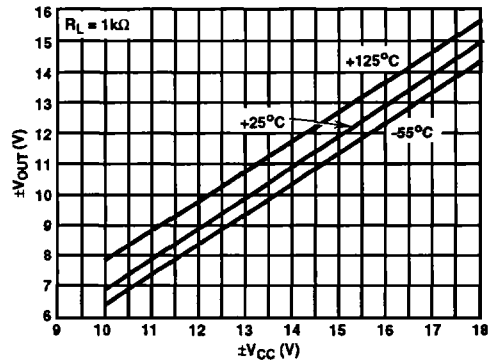

FIGURE 16. $\pm V_{OUT}$ vs $\pm V_{CC}$ vs TEMPERATURE

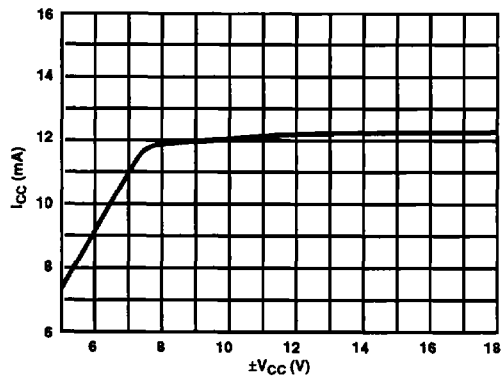

FIGURE 17. SUPPLY CURRENT vs SUPPLY VOLTAGE

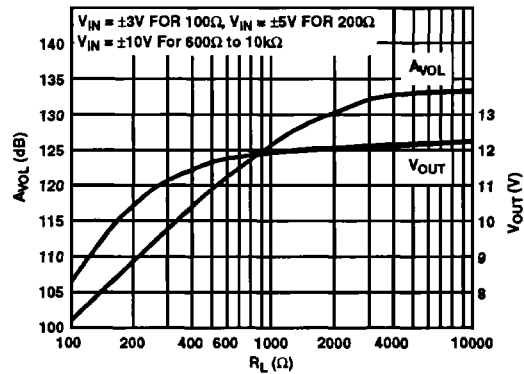

FIGURE 18. A_{VOL}/V_{OUT} vs R_L

Typical Performance Curves $V_S = \pm 15V, T_A = +25^\circ C$ (Continued)

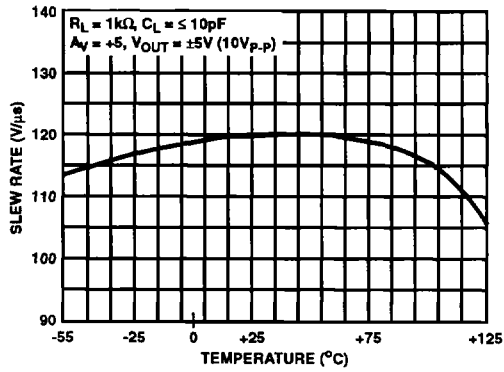

FIGURE 19. SLEW RATE vs TEMPERATURE

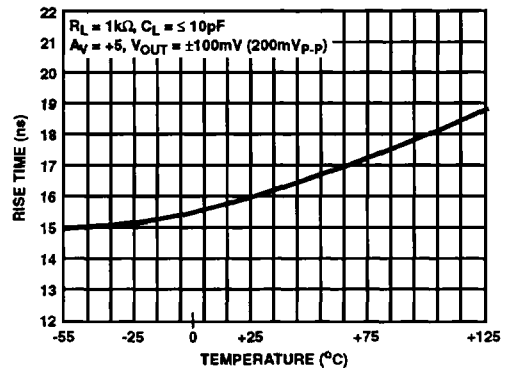

FIGURE 20. RISE TIME vs TEMPERATURE

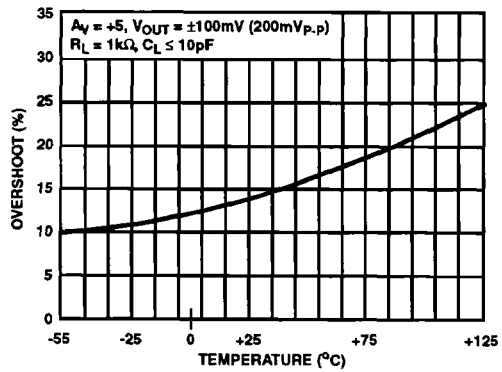

FIGURE 21. OVERSHOOT vs TEMPERATURE

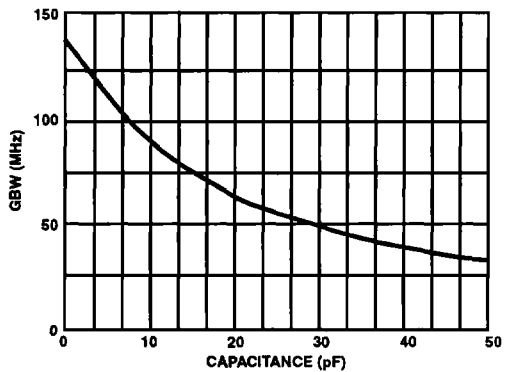

FIGURE 22. GAIN BANDWIDTH PRODUCT vs COMPENSATION CAPACITANCE TO GND

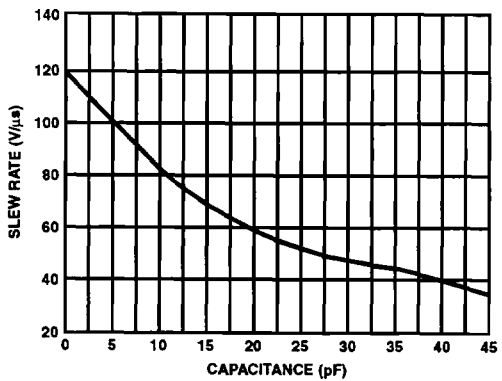

FIGURE 23. SLEW RATE vs COMPENSATION CAPACITANCE TO GND

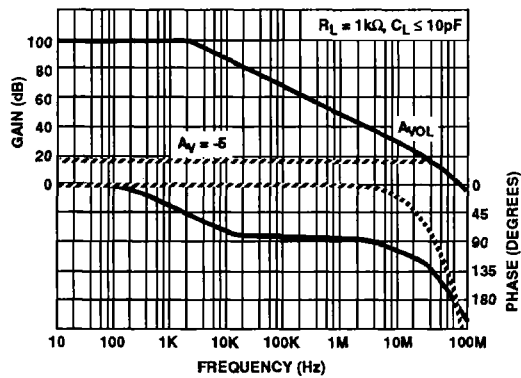

FIGURE 24. GAIN AND PHASE vs FREQUENCY

Typical Performance Curves $V_S = \pm 15V, T_A = +25^\circ C$ (Continued)

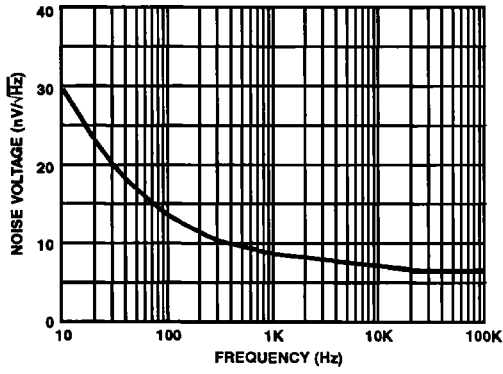

FIGURE 25. INPUT NOISE VOLTAGE DENSITY

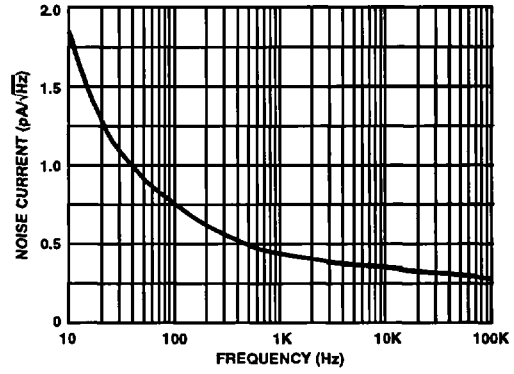

FIGURE 26. INPUT NOISE CURRENT DENSITY



FIGURE 27. PEAK TO PEAK NOISE 0.1HZ TO 10HZ
p-p(RTI) = 691.4nV, rms(RTI) = 116.5nV, $A_V = 25000$

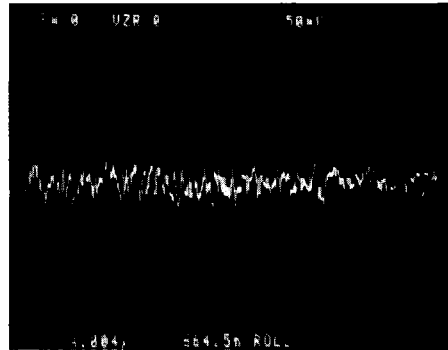

FIGURE 28. PEAK TO PEAK NOISE 0.1HZ TO 1MHZ
p-p(RTI) = 4.004μV, rms(RTI) = 664.5nV, $A_V = 25000$

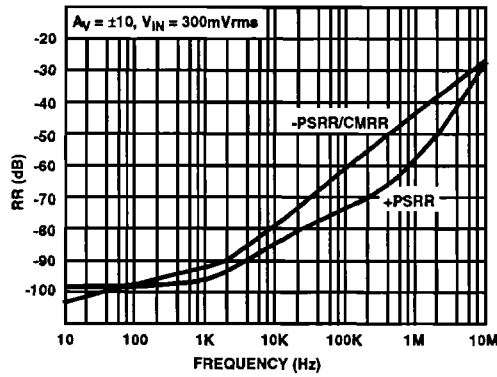

FIGURE 29. REJECTION RATIOS vs FREQUENCY