

△ USE WITH HAND TOOL 220190-1
 2. USE INSTRUCTION SHEET 408-4143

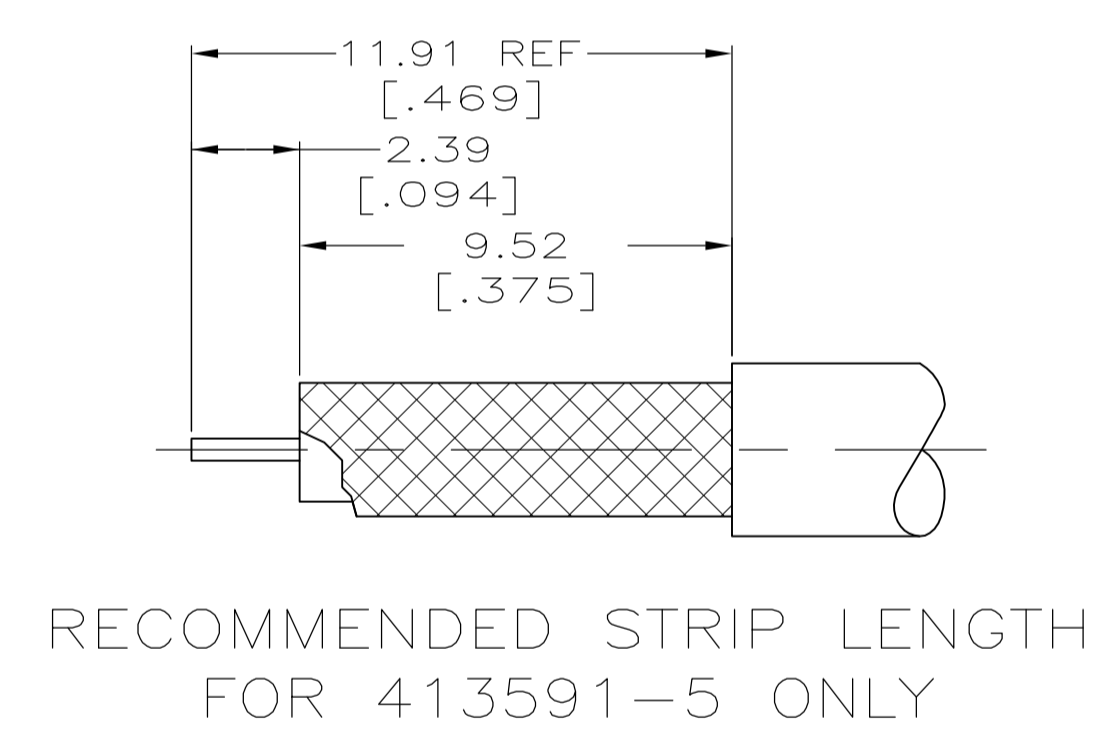
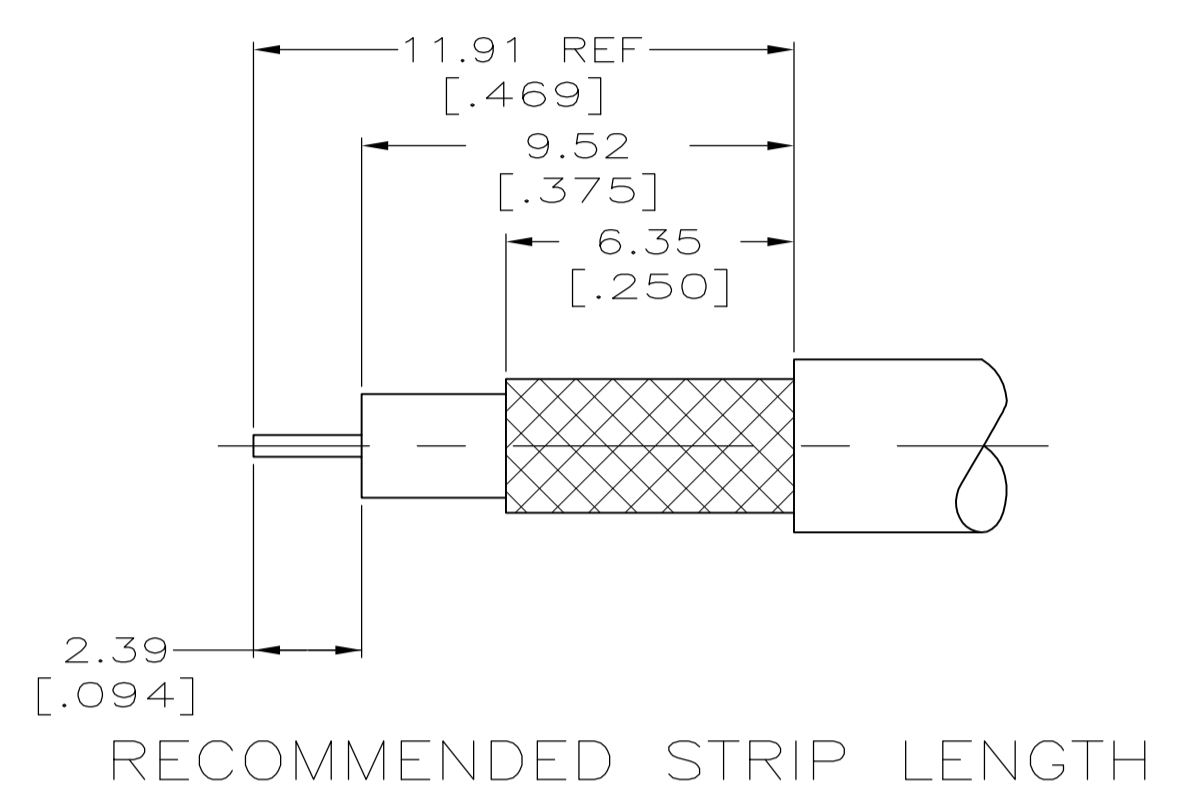
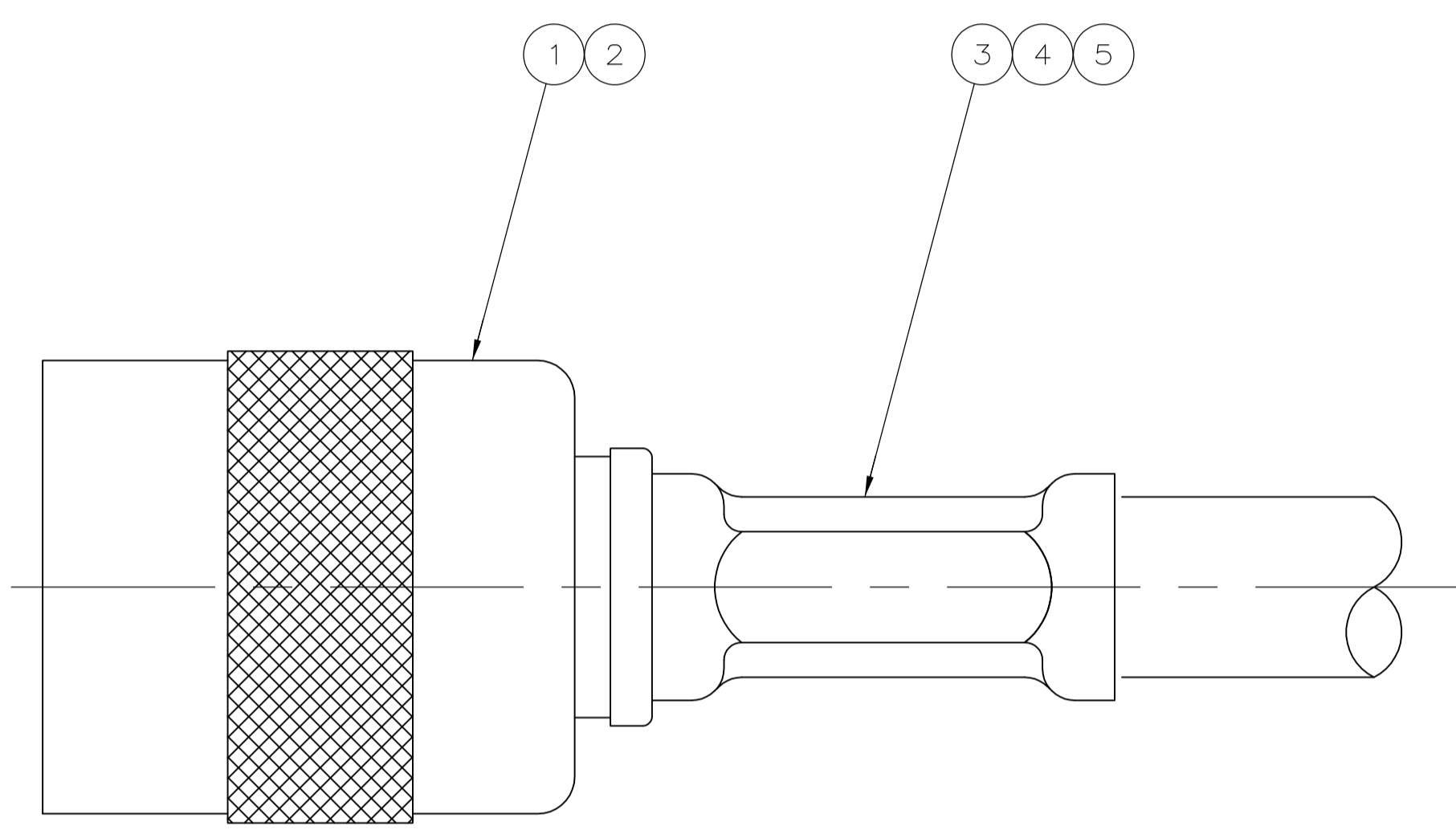

OBSOLETE	RG-59/U, 59A/U & 59B/U	1.07 [.042]	6.48 [.255]	852922-1	-	-	9-221132-1	413657-2	413863-1	9-413591-0
OBSOLETE	BELDEN 8218	1.07 [.042]	4.52 [.178]	852922-2	-	-	3-221132-3	413657-4	413863-2	1-413591-0
	RG-59 TYPE WITH .031 DIA CENTER CONTACT, BELDEN 9266, 9240 & 9259	1.07 [.042]	6.48 [.255]	852922-1	-	-	221132-6	413657-8	413863-1	413591-9
OBSOLETE	RG-179/U, 179A/U, 179B/U, 187/U & 187A/U	1.07 [.042]	4.52 [.178]	852922-2	227194-2	222001-4	413658-9	413657-6	413863-2	413591-8
OBSOLETE	AT&T 734A	1.07 [.042]	6.48 [.255]	852922-1	-	-	2-221132-0	413657-8	413863-4	413591-7
OBSOLETE	TIMES RG-59/U, DOUBLE BRAID, .270 OD JACKET	1.07 [.042]	8.23 [.324]	852922-3	-	-	221132-9	413657-2	413863-1	413591-6
OBSOLETE	BELDEN 8281, 9231 & AT&T 728	1.07 [.042]	8.23 [.324]	852922-3	-	-	221132-9	413657-8	413863-3	413591-5
OBSOLETE	AT&T KS 19224 L2 CABLE	1.07 [.042]	4.52 [.178]	852922-2	227194-2	222001-4	413658-6	413657-6	413863-2	413591-4
OBSOLETE	BELDEN 8218	1.07 [.042]	4.52 [.178]	852922-2	-	-	3-221132-3	413657-4	413863-2	413591-3
OBSOLETE	RG-59/U, 59A/U & 59B/U	1.07 [.042]	6.48 [.255]	852922-1	-	-	9-221132-1	413657-2	413863-1	413591-2
OBSOLETE	BELDEN 88241	1.07 [.042]	6.48 [.255]	852922-1	-	-	9-413658-3	413657-2	413863-1	413591-1

FOR USE WITH CABLE	CONTACT CRIMP (SQUARE)	FERRULE CRIMP (HEX)	DIE SET △1	⑤ TUBING, PLASTIC QTY=1	④ TUBING QTY=1	③ FERRULE QTY=1	② CONTACT QTY=1	① PLUG ASSY QTY=1	PART NUMBER
--------------------	------------------------	---------------------	------------	-------------------------	----------------	-----------------	-----------------	-------------------	-------------

THIS DRAWING IS A CONTROLLED DOCUMENT.

DIMENSIONS: INCHES	TOLERANCES UNLESS OTHERWISE SPECIFIED:	DIN J.L.GROFT 7-6-89	Tyco Electronics Tyco Electronics Corporation Harrisburg, PA 17105-3608
0 PLC ± -	1 PLC ± -	7-13-90	
2 PLC ± 0.41 [016]	3 PLC ± -	7-17-90	NAME: M. PHILLIPS
4 PLC ± -	ANGLES ± -		PRODUCT SPEC: PLUG, 75 OHM, HEX CRIMP, TNC
MATERIAL: -	FINISH: -	SIZE: A1	SCALE: 6:1
		WEIGHT: -	SHEET 1 OF 1
		CUSTOMER DRAWING	REV H2