

Aluminum Capacitors General Purpose, Miniature, Radial Lead

FEATURES

- +105 °C
- Suitable for long life applications
- Material categorization: for definitions of compliance please see www.vishay.com/doc?99912

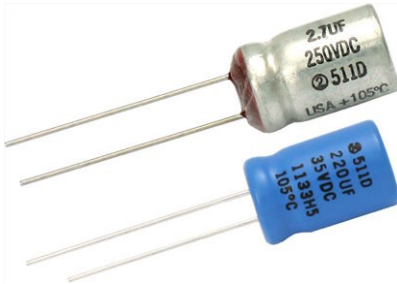

QUICK REFERENCE DATA	
DESCRIPTION	VALUE
Nominal case size Ø D x L in mm	0.236" x 0.433" [6.0 x 11.0] to 0.709" x 1.417" [18.0 x 36.0]
Operating temperature	-40 °C to +105 °C
Rated capacitance range, C _R	1 µF to 10 000 µF
Tolerance on C _R	± 20 %
Rated voltage range, U _R	6.3 WV _{DC} to 250 WV _{DC}
Termination	2 or 3 radial leads
Life validation test at 105 °C	1000 h (diameter ≤ 0.315" [8.0]): 2000 h (diameter > 0.315" [8.0]): ΔCAP ≤ 15 % (6.3 WV _{DC} to 16 WV _{DC}), ≤ 10 % (25 WV _{DC} to 250 WV _{DC}) from initial measurement. ΔESR ≤ 1.2 x initial specified limit. ΔDCL ≤ initial specified limit
Shelf life at 105 °C	500 h: ΔCAP ≤ 10 % from initial measurement. ΔESR 1.2 x initial specified limit. ΔDCL ≤ 2 x initial specified limit.
DC leakage current (after 5 min charge)	I = 0.005 CV (6.3 V _{DC} to 63 V _{DC}) I = 0.01 CV (100 V _{DC} to 250 V _{DC}) I in µA, C in µF, V in Volts

RIPPLE CURRENT MULTIPLIERS				
TEMPERATURE				
AMBIENT TEMPERATURE		MULTIPLIERS		
+105 °C		0.4		
+95 °C		0.7		
+85 °C		1.0		
+75 °C		1.2		
≤ +65 °C		1.4		
FREQUENCY (Hz)				
WV _{DC}	50 TO 60	100 TO 120	300 TO 400	1K TO 100K
6.3 to 25	0.85	1.00	1.05	1.1
26 to 250	0.80	1.00	1.30	1.4

LEAD LENGTH FOR D TERMINATION		
CASE CODE	L ₁ (-)	L ₂ (+)
D	0.591 [15.0]	0.787 [20.0]

DIMENSIONS in inches [millimeters]										
CASE CODE	NOMINAL		STYLES 2 AND 4		STYLES 3 AND 5		LEAD SPACING		LEAD DIAMETER	
	D	L	D (max.)	L (max.)	D (max.)	L (max.)	S ± 0.024 [0.60]	T ± 0.02 [0.50]	NOMINAL	AWG NO.
AA	0.236 [6.0]	0.433 [11.0]	0.256 [6.5]	0.472 [12.0]	0.256 [6.5]	0.512 [13.0]	0.098 [2.5]	n/a	0.025 [0.63]	22
BB	0.315 [8.0]	0.472 [12.0]	0.335 [8.5]	0.512 [13.0]	0.335 [8.5]	0.551 [14.0]	0.138 [3.5]	n/a	0.025 [0.63]	22
CC	0.394 [10.0]	0.512 [13.0]	0.413 [10.5]	0.563 [14.3]	0.413 [10.5]	0.630 [16.0]	0.197 [5.0]	n/a	0.025 [0.63]	22
CD	0.394 [10.0]	0.630 [16.0]	0.413 [10.5]	0.669 [17.0]	0.413 [10.5]	0.740 [18.8]	0.197 [5.0]	n/a	0.025 [0.63]	22
CG	0.394 [10.0]	0.787 [20.0]	0.413 [10.5]	0.846 [21.5]	0.413 [10.5]	0.906 [23.0]	0.197 [5.0]	n/a	0.025 [0.63]	22
DG	0.492 [12.5]	0.787 [20.0]	0.512 [13.0]	0.846 [21.5]	0.512 [13.0]	0.906 [23.0]	0.197 [5.0]	0.098 [2.5]	0.032 [0.81]	20
DK	0.492 [12.5]	0.984 [25.0]	0.512 [13.0]	1.043 [26.5]	0.512 [13.0]	1.142 [29.0]	0.197 [5.0]	0.098 [2.5]	0.032 [0.81]	20
EK	0.630 [16.0]	0.984 [25.0]	0.650 [16.5]	1.031 [26.2]	0.650 [16.5]	1.098 [27.9]	0.295 [7.5]	0.150 [3.8]	0.032 [0.81]	20
EN	0.630 [16.0]	1.260 [32.0]	0.650 [16.5]	1.319 [33.5]	0.650 [16.5]	1.417 [36.0]	0.295 [7.5]	0.150 [3.8]	0.032 [0.81]	20
ER	0.630 [16.0]	1.417 [36.0]	0.650 [16.5]	1.476 [37.5]	0.650 [16.5]	1.575 [40.0]	0.295 [7.5]	0.150 [3.8]	0.032 [0.81]	20
FR	0.709 [18.0]	1.417 [36.0]	0.728 [18.5]	1.476 [37.5]	0.728 [18.5]	1.575 [40.0]	0.295 [7.5]	0.150 [3.8]	0.032 [0.81]	20

TAPE AND REEL, SPECIFICATIONS TO EIA-468 in inches [millimeters]

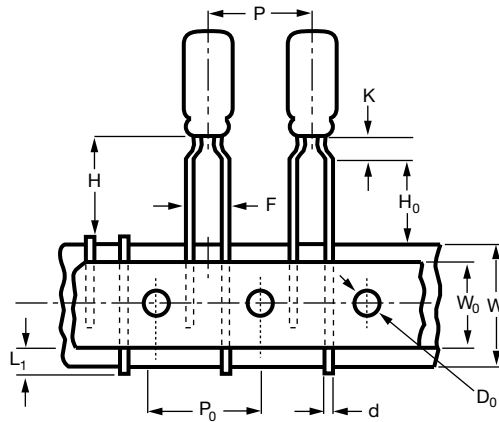
Formed Leads

DIMENSIONS in inches [millimeters]		
CASE SIZE	F LEAD SPACING	STD. QTY/REEL
0.236 x 0.433 [6.0 x 11.0]	0.197 [5.0]	800
0.315 x 0.472 [8.0 x 12.0]	0.197 [5.0]	700

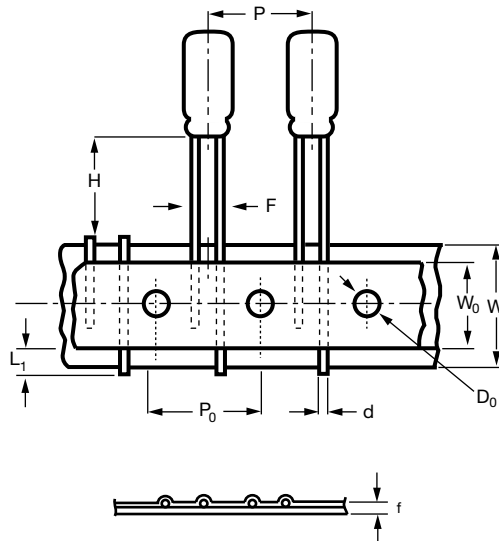
Unformed Leads

DIMENSIONS in inches [millimeters]		
CASE SIZE	F LEAD SPACING	STD. QTY/REEL
0.236 x 0.433 [6.0 x 11.0]	0.098 ⁽¹⁾ [2.5]	800
0.315 x 0.472 [8.0 x 12.0]	0.140 ⁽¹⁾ [3.5]	700
0.394 x 0.512 [10.0 x 13.0]	0.197 [5.0]	500
0.394 x 0.630 [10.0 x 16.0]	0.197 [5.0]	500
0.394 x 0.787 [10.0 x 20.0]	0.197 [5.0]	500

Note
⁽¹⁾ Available as special order



DIMENSIONS in inches [millimeters]					
ITEM	CASE SIZE (Diameter x Length)				
	0.236 x 0.433 [6.0 x 11.0]	0.315 x 0.472 [8.0 x 12.0]	0.394 x 0.512 [10.0 x 13.0]	0.394 x 0.630 [10.0 x 16.0]	0.394 x 0.787 [10.0 x 20.0]
d - Lead-wire diameter	0.025 [0.63]	0.025 [0.63]	0.025 [0.63]	0.025 [0.63]	0.020 [0.5]
P - Pitch of component	0.500 [12.7]	0.500 [12.7]	0.500 [12.7]	0.500 [12.7]	0.500 [12.7]
P ₀ - Feed hole pitch	0.500 [12.7]	0.500 [12.7]	0.500 [12.7]	0.500 [12.7]	0.500 [12.7]
F - Lead-to-lead distance	0.197 [5.0]	0.197 [5.0]	0.197 [5.0]	0.197 [5.0]	0.197 [5.0]
K - Clinch height	0.098 [2.5]	0.157 [4.0]	n/a	n/a	n/a
H - Height of component from tape center	0.728 [18.5]	0.787 [20.0]	0.906 [23.0]	0.906 [23.0]	0.906 [23.0]
H ₀ - Lead-wire clinch height	0.630 [16.0]	0.630 [16.0]	n/a	n/a	n/a
W - Tape width	0.709 [18.0]	0.709 [18.0]	0.709 [18.0]	0.709 [18.0]	0.709 [18.0]
W ₀ - Hold down tape width	0.591 [15.0]	0.591 [15.0]	0.591 [15.0]	0.591 [15.0]	0.591 [15.0]
D ₀ - Feed hole diameter	0.157 [4.0]	0.157 [4.0]	0.157 [4.0]	0.157 [4.0]	0.157 [4.0]
t - Total tape thickness	0.028 [0.7]	0.028 [0.7]	0.157 [4.0]	0.157 [4.0]	0.157 [4.0]
L ₁ - Maximum lead protrusion	0.118 [3.0]	0.118 [3.0]	0.118 [3.0]	0.118 [3.0]	0.118 [3.0]

Note

- Terminal code "I" = tape and reel. Terminal code "+" = tape and ammo. Positive leader is standard. Negative leader is available by special order.

ORDERING EXAMPLE

Electrolytic capacitor 511D series: 511D 157 M 063 CG 4 D

DESCRIPTION	
CODE	EXPLANATION
511D	Product type
157	Capacitance value (150 µF)
M	Tolerance (M = ± 20 %)
063	Voltage rating at 105 °C (063 = 63 V)
DF	Can size (see Dimensions table)
4	Sleeve and sealing (4 = P.V.C. sleeve)
D	Packaging (D = bulk; straight leads)

Note

- For lead (Pb)-free / RoHS compliant products add suffix "E3" to part number.
Example: 511D157M063CG4DE3

ELECTRICAL DATA AND ORDERING INFORMATION							
CAPACITANCE (µF)	PART NUMBER	NOMINAL CASE SIZE D x L IN INCHES [mm]	MAX. ESR AT +25 °C (Ω)		MAX. RIPPLE AT +85 °C (A)		MAX. IMPEDANCE AT +25 °C (Ω) 100 Hz
			120 Hz	20 kHz TO 40 kHz	120 Hz	20 kHz TO 40 kHz	
6.3 WV_{DC} AT +105 °C, SURGE = 8 V							
150.0	511D157M6R3AA4D	0.236 x 0.433 [6.0 x 11.0]	3.130	2.720	0.123	0.132	2.800
1200.0	511D128M6R3CG4D	0.394 x 0.787 [10.0 x 20.0]	0.420	0.270	0.590	0.741	0.286
4700.0	511D478M6R3EK4D	0.630 x 0.984 [16.0 x 25.0]	0.121	0.075	1.580	2.010	0.090
10 000.0	511D109M6R3FR4D	0.630 x 1.417 [16.0 x 36.0]	0.068	0.050	2.640	3.070	0.061
10 WV_{DC} AT +105 °C, SURGE = 13 V							
100.0 ⁽¹⁾	511D107M010AA4D	0.236 x 0.433 [6.0 x 11.0]	4.073	2.800	0.108	0.131	2.900
220.0 ⁽¹⁾	511D227M010BB4D	0.315 x 0.472 [8.0 x 12.0]	1.855	1.150	0.198	0.252	1.300
1000.0	511D108M010CG4D	0.394 x 0.787 [10.0 x 20.0]	0.407	0.290	0.603	0.715	0.290
3300.0	511D338M010EK4D	0.630 x 0.984 [16.0 x 25.0]	0.166	0.086	1.350	1.880	0.094
4700.0	511D478M010EN4D	0.630 x 1.260 [16.0 x 32.0]	0.122	0.060	1.740	2.480	0.067
16 WV_{DC} AT +105 °C, SURGE = 20 V							
150.0	511D157M016BB4D	0.315 x 0.472 [8.0 x 12.0]	2.433	1.250	0.173	0.241	1.250
470.0 ⁽¹⁾	511D477M016CD4D	0.394 x 0.630 [10.0 x 16.0]	0.748	0.442	0.419	0.522	0.442
1500.0	511D158M016DK4D	0.492 x 0.984 [12.5 x 25.0]	0.243	0.140	0.971	1.270	0.140
2200.0	511D228M016EK4D	0.630 x 0.984 [16.0 x 25.0]	0.176	0.090	1.310	1.840	0.098
3300.0	511D338M016EN4D	0.630 x 1.260 [16.0 x 32.0]	0.147	0.062	1.580	2.440	0.067

Note

- ⁽¹⁾ These values are normally stocked. See Original Ratings for more values that are stocked.



ELECTRICAL DATA AND ORDERING INFORMATION							
CAPACITANCE (μF)	PART NUMBER	NOMINAL CASE SIZE D x L IN INCHES [mm]	MAX. ESR AT +25 °C (Ω)		MAX. RIPPLE AT +85 °C (A)		MAX. IMPEDANCE AT +25 °C (Ω) 100 Hz
			120 Hz	20 kHz TO 40 kHz	120 Hz	20 kHz TO 40 kHz	
20 WV_{DC} AT +105 °C, SURGE = 25 V							
120.0	511D127M020BB4D	0.315 x 0.472 [8.0 x 12.0]	2.650	1.350	0.166	0.232	1.350
220.0	511D227M020CC4D	0.394 x 0.512 [10.0 x 13.0]	1.472	0.950	0.266	0.331	0.900
330.0	511D337M020CD4D	0.394 x 0.630 [10.0 x 16.0]	0.981	0.550	0.350	0.468	0.500
470.0	511D477M020CG4D	0.394 x 0.787 [10.0 x 20.0]	0.679	0.300	0.467	0.703	0.305
1500.0	511D158M020EK4D	0.630 x 0.984 [16.0 x 25.0]	0.243	0.110	1.120	1.660	0.100
2200.0	511D228M020EN4D	0.630 x 1.260 [16.0 x 32.0]	0.163	0.080	1.510	2.150	0.080
3300.0	511D338M020FR4D	0.630 x 1.417 [16.0 x 36.0]	0.128	0.060	1.920	2.810	0.064
25 WV_{DC} AT +105 °C, SURGE = 32 V							
47.0 ⁽¹⁾	511D476M025AA4D	0.236 x 0.433 [6.0 x 11.0]	6.120	2.940	0.089	0.127	2.950
100.0	511D107M025BB4D	0.315 x 0.472 [8.0 x 12.0]	2.914	1.350	0.158	0.232	1.350
1200.0	511D128M025EK4D	0.630 x 0.984 [16.0 x 25.0]	0.239	0.110	1.127	1.660	0.105
2200.0	511D228M025ER4D	0.630 x 1.417 [16.0 x 36.0]	0.162	0.064	1.580	2.520	0.074
35 WV_{DC} AT +105 °C, SURGE = 44 V							
120.0	511D127M035CC4D	0.394 x 0.512 [10.0 x 13.0]	1.830	1.010	0.239	0.323	0.980
330.0	511D337M035CG4D	0.394 x 0.787 [10.0 x 20.0]	0.677	0.305	0.468	0.697	0.310
1000.0	511D108M035EK4D	0.630 x 0.984 [16.0 x 25.0]	0.223	0.110	1.170	1.660	0.112
1500.0	511D158M035EN4D	0.630 x 1.260 [16.0 x 32.0]	0.165	0.078	1.490	2.180	0.078
2200.0	511D228M035FR4D	0.709 x 1.417 [18.0 x 36.0]	0.121	0.060	1.980	2.810	0.062
40 WV_{DC} AT +105 °C, SURGE = 50 V							
100.0	511D107M040CC4D	0.394 x 0.512 [10.0 x 13.0]	1.939	1.010	0.232	0.323	0.981
220.0	511D227M040CG4D	0.394 x 0.787 [10.0 x 20.0]	0.883	0.305	0.411	0.698	0.311
330.0	511D337M040DG4D	0.492 x 0.787 [12.5 x 20.0]	0.588	0.210	0.573	0.959	0.221
470.0	511D477M040DK4D	0.492 x 0.984 [12.5 x 25.0]	0.407	0.151	0.719	1.190	0.157
1000.0	511D108M040EN4D	0.630 x 1.260 [16.0 x 32.0]	0.193	0.078	1.390	2.180	0.078
50 WV_{DC} AT +105 °C, SURGE = 63 V							
47.0	511D476M050BB4D	0.315 x 0.472 [8.0 x 12.0]	3.884	1.510	0.137	0.221	1.450
120.0	511D127M050CD4D	0.394 x 0.630 [10.0 x 16.0]	1.320	0.466	0.302	0.509	0.488
270.0	511D277M050DG4D	0.492 x 0.787 [12.5 x 20.0]	0.601	0.221	0.567	0.937	0.231
1000.0	511D108M050ER4D	0.630 x 1.417 [16.0 x 36.0]	0.161	0.065	1.590	2.510	0.068
1500.0	511D158M050FR4D	0.709 x 1.417 [18.0 x 36.0]	0.153	0.065	1.760	2.710	0.068
63 WV_{DC} AT +105 °C, SURGE = 79 V							
47.0	511D476M063CC4D	0.394 x 0.512 [10.0 x 13.0]	3.076	1.170	0.184	0.299	1.110
150.0	511D157M063CG4D	0.394 x 0.787 [10.0 x 20.0]	1.010	0.331	0.385	0.671	0.341
470.0	511D477M063EK4D	0.630 x 0.984 [16.0 x 25.0]	0.307	0.125	0.995	1.560	0.125
1200.0	511D128M063FR4D	0.709 x 1.417 [18.0 x 36.0]	0.165	0.065	1.690	2.710	0.068
75 WV_{DC} AT +105 °C, SURGE = 90 V							
33.0	511D336M075CC4D	0.394 x 0.512 [10.0 x 13.0]	4.440	1.210	0.153	0.295	1.210
100.0	511D107M075CG4D	0.394 x 0.787 [10.0 x 20.0]	1.460	0.341	0.318	0.661	0.341
150.0	511D157M075DG4D	0.492 x 0.787 [12.5 x 20.0]	1.010	0.261	0.439	0.862	0.261
220.0	511D227M075DK4D	0.492 x 0.984 [12.5 x 25.0]	0.666	0.211	0.589	1.050	0.211
470.0	511D477M075EN4D	0.630 x 1.260 [16.0 x 32.0]	0.307	0.105	1.110	1.880	0.105
100 WV_{DC} AT +105 °C, SURGE = 125 V							
4.7 ⁽¹⁾	511D475M100AA4D	0.236 x 0.433 [6.0 x 11.0]	30.79	4.310	0.041	0.106	4.210
10.0 ⁽¹⁾	511D106M100BB4D	0.314 x 0.472 [8.0 x 12.0]	14.63	1.810	0.071	0.202	1.710
33.0	511D336M100CD4D	0.394 x 0.630 [10.0 x 16.0]	4.440	0.531	0.165	0.477	0.531
120.0	511D127M100DK4D	0.492 x 0.984 [12.5 x 25.0]	1.210	0.215	0.437	1.030	0.215
330.0	511D337M100ER4D	0.630 x 1.260 [16.0 x 32.0]	0.444	0.076	0.958	2.320	0.078
470.0	511D477M100FR4D	0.709 x 1.417 [18.0 x 36.0]	0.361	0.071	1.150	2.610	0.074
160 WV_{DC} AT +105 °C, SURGE = 185 V							
10.0	511D106M160CD4D	0.394 x 0.630 [10.0 x 16.0]	16.09	4.910	0.086	0.157	4.910
22.0	511D226M160DG4D	0.492 x 0.787 [12.5 x 20.0]	7.330	3.210	0.162	0.245	3.210
33.0	511D336M160DK4D	0.492 x 0.984 [12.5 x 25.0]	4.880	2.250	0.216	0.319	2.250
100.0	511D107M160ER4D	0.630 x 1.260 [16.0 x 32.0]	1.610	0.531	0.504	0.876	0.531

Note

⁽¹⁾ These values are normally stocked. See Original Ratings for more values that are stocked.



ELECTRICAL DATA AND ORDERING INFORMATION							
CAPACITANCE (μ F)	PART NUMBER	NOMINAL CASE SIZE D x L IN INCHES [mm]	MAX. ESR AT +25 °C (Ω)		MAX. RIPPLE AT +85 °C (A)		MAX. IMPEDANCE AT +25 °C (Ω) 100 Hz
			120 Hz	20 kHz TO 40 kHz	120 Hz	20 kHz TO 40 kHz	
200 WV_{DC} AT +105 °C, SURGE = 225 V							
1.5	511D155M200AA4D	0.236 x 0.433 [6.0 x 11.0]	110.010	33.110	0.021	0.038	33.010
22.0	511D226M200DG4D	0.492 x 0.787 [12.5 x 20.0]	7.330	3.210	0.162	0.245	3.210
33.0	511D336M200DK4D	0.492 x 0.984 [12.5 x 25.0]	4.880	2.250	0.216	0.319	2.250
47.0	511D476M200EK4D	0.630 x 0.984 [16.0 x 25.0]	3.384	1.210	0.299	0.501	1.210
120.0	511D127M200FR4D	0.709 x 1.417 [18.0 x 36.0]	1.420	0.481	0.577	0.991	0.491
250 WV_{DC} AT +105 °C, SURGE = 275 V							
10.0	511D106M250CG4D	0.394 x 0.787 [10.0 x 20.0]	16.090	3.760	0.096	0.198	3.760
33.0	511D336M250EK4D	0.630 x 0.984 [16.0 x 25.0]	4.880	1.270	0.249	0.489	1.270
47.0	511D476M250EN4D	0.630 x 1.260 [16.0 x 32.0]	3.380	0.721	0.331	0.717	0.721

Note

(1) These values are normally stocked. See Original Ratings for more values that are stocked.

ORIGINAL RATINGS		
CAPACITANCE (μ F)	CASE CODE	PART NUMBER
6.3 WV_{DC} AT +105 °C, SURGE = 8 V		
470.0	CC	511D477M6R3CC4D
1000.0	CG	511D108M6R3CG4D
2200.0	DK	511D228M6R3DK4D
10 WV_{DC} AT +85 °C, SURGE = 13 V		
470.0	CD	511D477M010CD4D
1000.0	DG	511D108M010DG4D
4700.0	ER	511D478M010ER4D
16 WV_{DC} AT +105 °C, SURGE = 20 V		
47.0 (1)	AA	511D476M016AA4D
100.0 (1)	BB	511D107M016BB4D
220.0	CC	511D227M016CC4D
25 WV_{DC} AT +105 °C, SURGE = 32 V		
220.0	CD	511D227M025CD4D
470.0	DG	511D477M025DG4D
1000.0	EK	511D108M025EK4D
35 WV_{DC} AT +105 °C, SURGE = 44 V		
22.0	AA	511D226M035AA4D
47.0	BB	511D476M035BB4D
100.0 (1)	CC	511D107M035CC4D
220.0	CG	511D227M035CG4D
470.0	DK	511D477M035DK4D
1000.0	EN	511D108M035EN4D
50 WV_{DC} AT +105 °C, SURGE = 63 V		
47.0	CC	511D476M050CC4D
220.0	DK	511D227M050DK4D
63 WV_{DC} AT +105 °C, SURGE = 70 V		
10.0 (1)	AA	511D106M063AA4D
22.0	BB	511D226M063BB4D
47.0 (1)	CD	511D476M063CD4D
100.0	CG	511D107M063CG4D
220.0	EK	511D227M063EK4D
470.0	EN	511D477M063EN4D
100 WV_{DC} AT +105 °C, SURGE = 125 V		
22.0	CD	511D226M100CD4D
47.0	CG	511D476M100CG4D
220.0	EN	511D227M100EN4D

Note

(1) These values are normally stocked.

Statements about product lifetime are based on calculations and internal testing. They should only be interpreted as estimations. Also due to external factors, the lifetime in the field application may deviate from the calculated lifetime. In general, nothing stated herein shall be construed as a guarantee of durability.



Disclaimer

ALL PRODUCT, PRODUCT SPECIFICATIONS AND DATA ARE SUBJECT TO CHANGE WITHOUT NOTICE TO IMPROVE RELIABILITY, FUNCTION OR DESIGN OR OTHERWISE.

Vishay Intertechnology, Inc., its affiliates, agents, and employees, and all persons acting on its or their behalf (collectively, "Vishay"), disclaim any and all liability for any errors, inaccuracies or incompleteness contained in any datasheet or in any other disclosure relating to any product.

Vishay makes no warranty, representation or guarantee regarding the suitability of the products for any particular purpose or the continuing production of any product. To the maximum extent permitted by applicable law, Vishay disclaims (i) any and all liability arising out of the application or use of any product, (ii) any and all liability, including without limitation special, consequential or incidental damages, and (iii) any and all implied warranties, including warranties of fitness for particular purpose, non-infringement and merchantability.

Statements regarding the suitability of products for certain types of applications are based on Vishay's knowledge of typical requirements that are often placed on Vishay products in generic applications. Such statements are not binding statements about the suitability of products for a particular application. It is the customer's responsibility to validate that a particular product with the properties described in the product specification is suitable for use in a particular application. Parameters provided in datasheets and / or specifications may vary in different applications and performance may vary over time. All operating parameters, including typical parameters, must be validated for each customer application by the customer's technical experts. Product specifications do not expand or otherwise modify Vishay's terms and conditions of purchase, including but not limited to the warranty expressed therein.

Hyperlinks included in this datasheet may direct users to third-party websites. These links are provided as a convenience and for informational purposes only. Inclusion of these hyperlinks does not constitute an endorsement or an approval by Vishay of any of the products, services or opinions of the corporation, organization or individual associated with the third-party website. Vishay disclaims any and all liability and bears no responsibility for the accuracy, legality or content of the third-party website or for that of subsequent links.

Except as expressly indicated in writing, Vishay products are not designed for use in medical, life-saving, or life-sustaining applications or for any other application in which the failure of the Vishay product could result in personal injury or death. Customers using or selling Vishay products not expressly indicated for use in such applications do so at their own risk. Please contact authorized Vishay personnel to obtain written terms and conditions regarding products designed for such applications.

No license, express or implied, by estoppel or otherwise, to any intellectual property rights is granted by this document or by any conduct of Vishay. Product names and markings noted herein may be trademarks of their respective owners.