

PART NAME

TABLET ENCLOSURE

PART No.

TB-32614-B & TB-32614-W

REV. DATE

2-23-13

MATERIAL:  
ABS UL94-HB BLACK (SUFFIX-B)  
ABS UL94-V0 WHITE (SUFFIX-W)

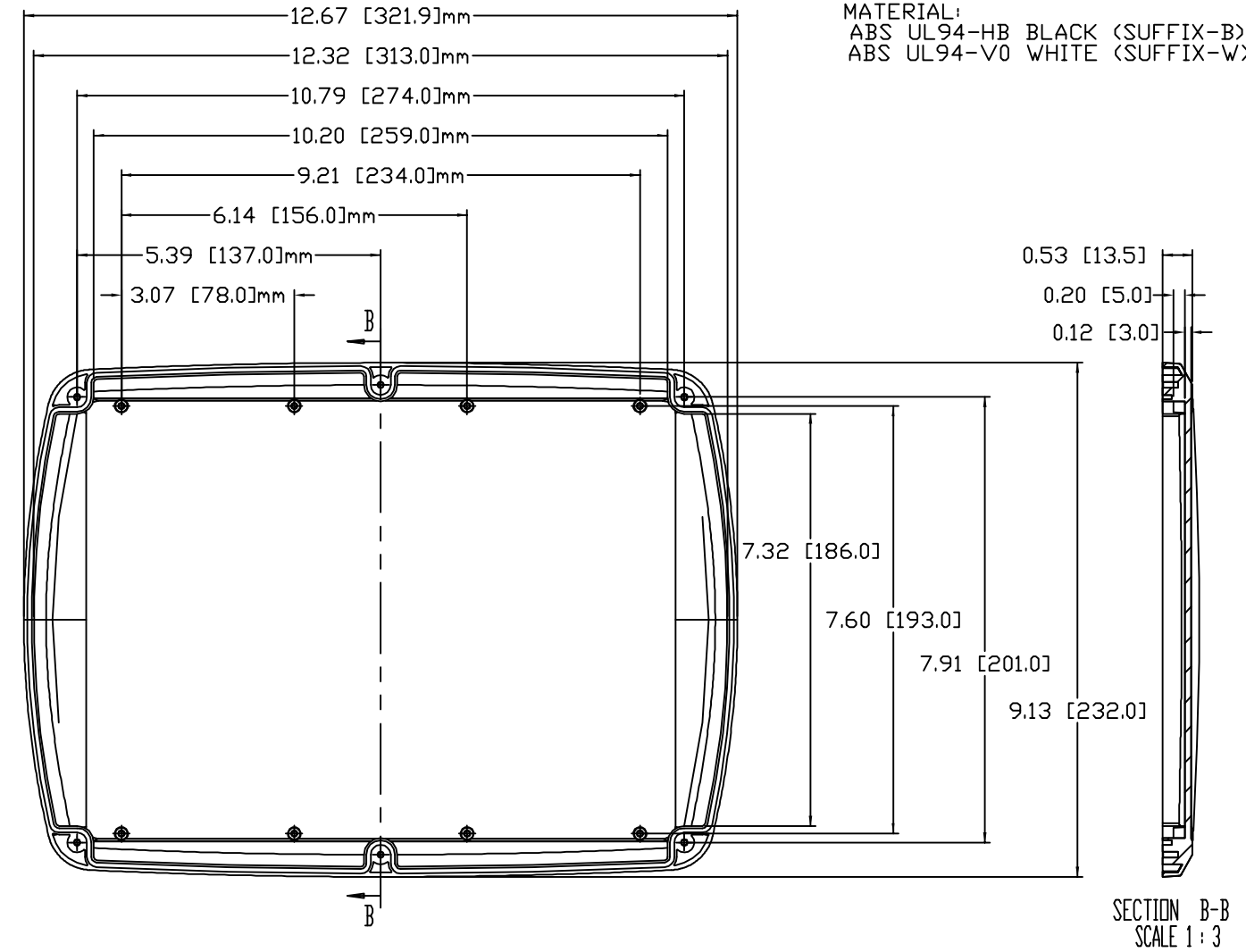
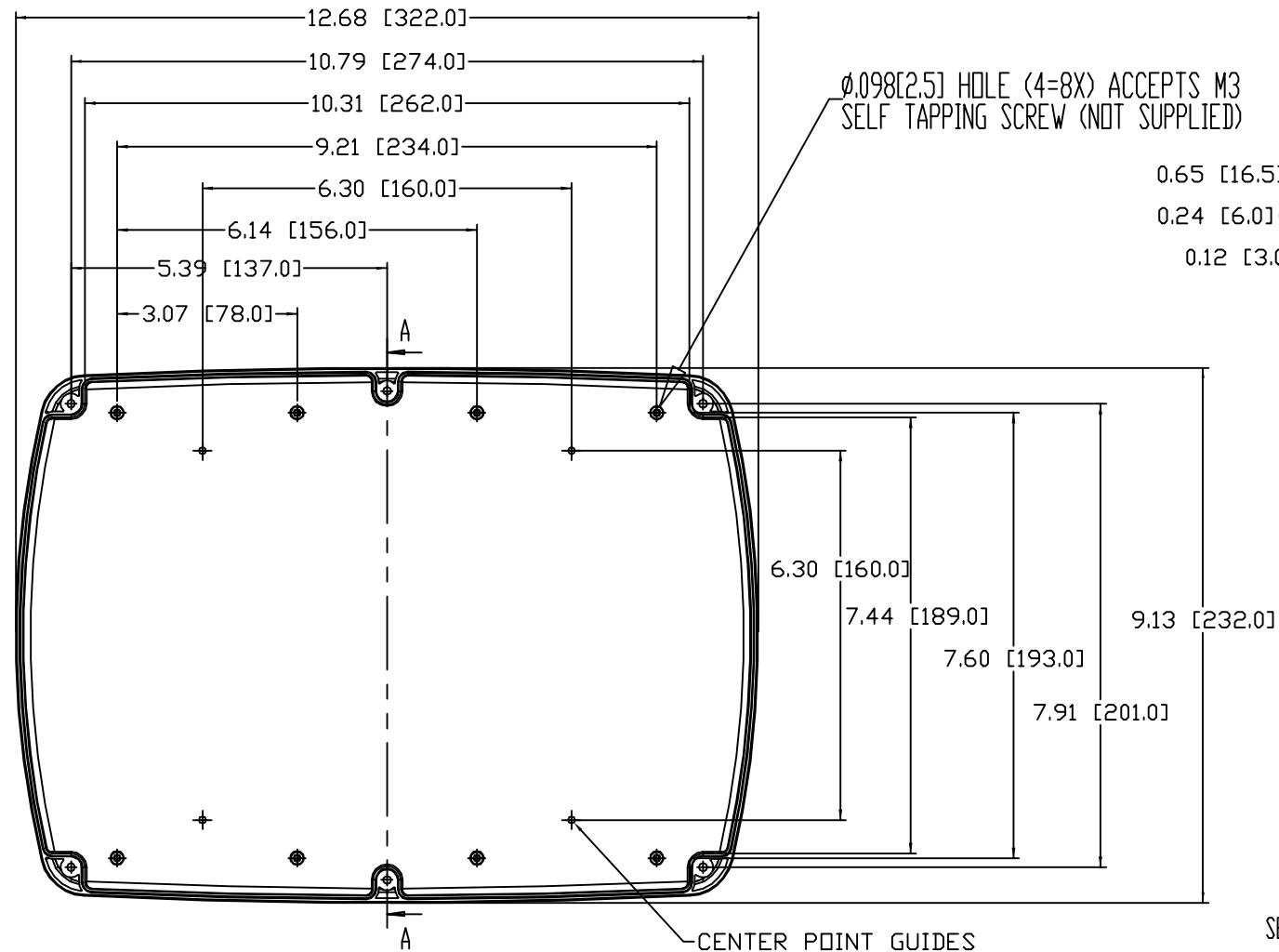

CENTER POINT GUIDES FOR DRILLING WALL MOUNTING HOLES (4X)

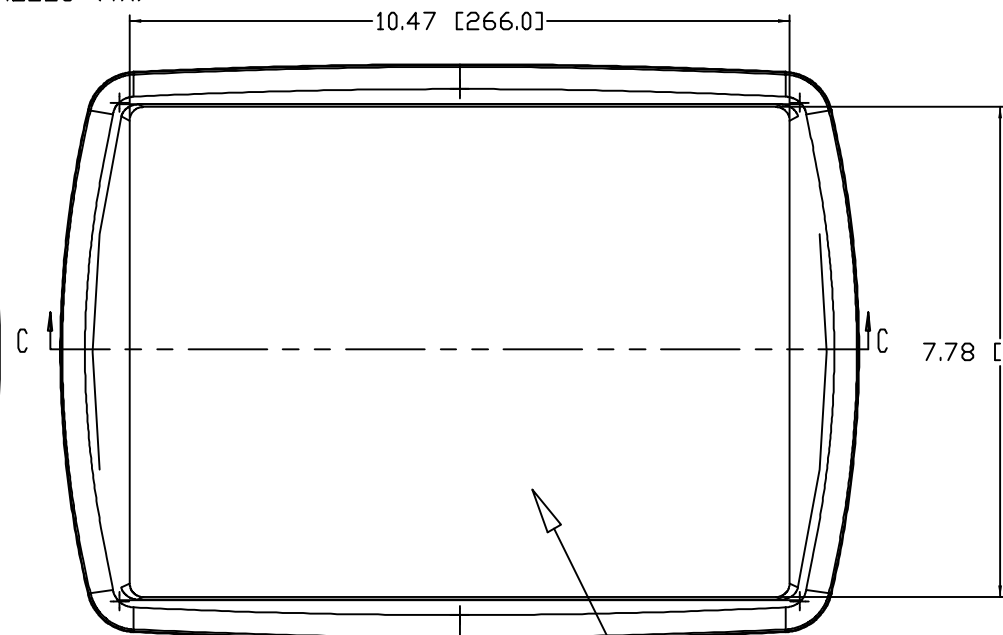
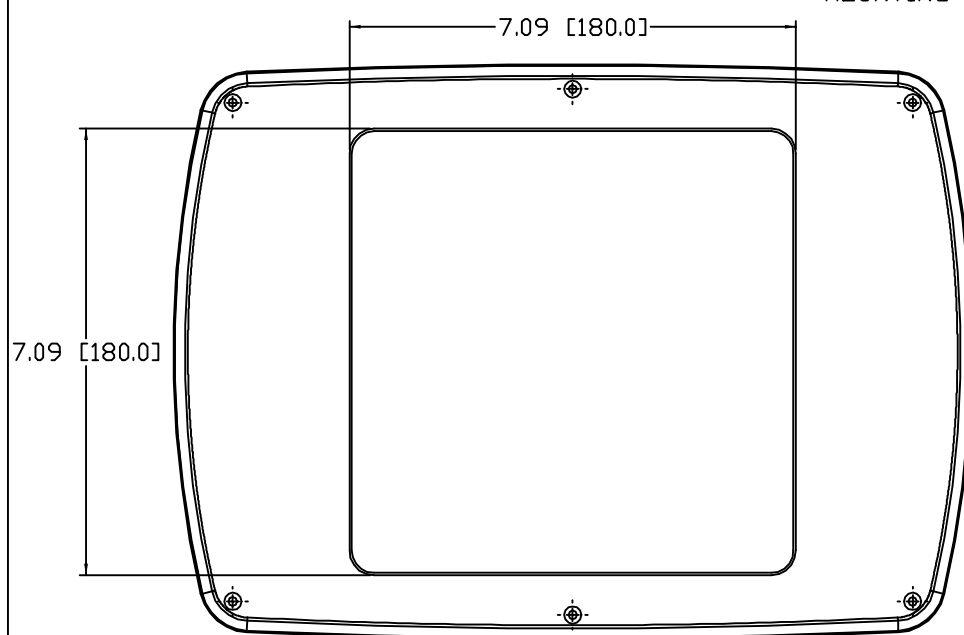

RECESSED AREA ACCEPTS 10.40 [264.16] LCD MODULE OR TOUCHSCREEN

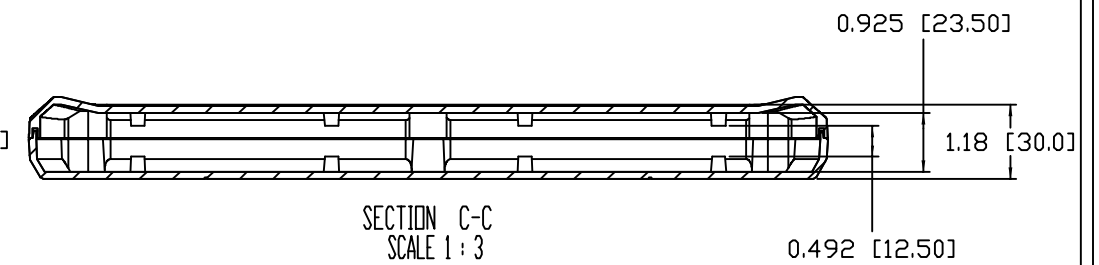

- NOTES:
- 1.) SIX (6) M3 X .63 [16] LG. SELF-TAPPING SCREWS SUPPLIED FOR ASSEMBLY
  - 2.) FOUR (4) ADD-ON RUBBER FEET SUPPLIED
  - 3.) ALL HOLE DIAMETERS HAVE +/- .005 [0.13] TOLERANCE  
ALL OTHER DIMENSIONS HAVE +/- .015 [0.38] TOLERANCE
  - 4.) DIMENSIONS ARE INCH [MILLIMETER]—THIRD ANGLE PROJECTION
  - 5.) OPTIONAL SILICONE SPONGE GASKET #TB-32614-GSK AVAILABLE