



DIFFERENTIAL-TO-LVDS BUFFER/DIVIDER W/INTERNAL TERMINATION

ICS889875

General Description



The ICS889875 is a high speed Differential-to-LVDS Buffer/Divider w/Internal Termination and is a member of the HiPerClockS™ family of high performance clock solutions from IDT. The ICS889875 has a selectable $\div 1$, $\div 2$, $\div 4$, $\div 8$, $\div 16$

output dividers. The clock input has internal termination resistors, allowing it to interface with several differential signal types while minimizing the number of required external components. The device is packaged in a small, 3mm x 3mm VFQFN package, making it ideal for use on space-constrained boards.

Features

- Two LVDS outputs
- Frequency divide select options: $\div 1$, $\div 2$, $\div 4$, $\div 8$, $\div 16$
- IN, nIN input can accept the following differential input levels: LVPECL, LVDS, CML
- Output frequency: >2GHz
- Cycle-to-cycle jitter: 1ps RMS (maximum)
- Total jitter: 10ps (typical)
- Output skew: 15ps (maximum)
- Part-to-part skew: 280ps (maximum)
- Propagation Delay: 1140ps (maximum)
- Full 2.5V supply mode
- -40°C to 85°C ambient operating temperature
- Available in both standard (RoHS 5) and lead-free (RoHS 6) packages

Block Diagram

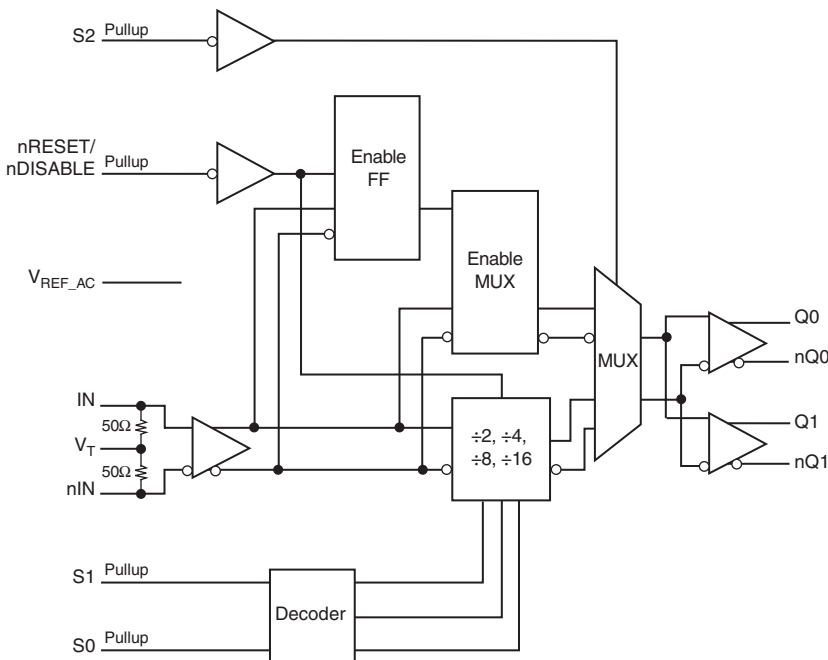

Pin Assignment

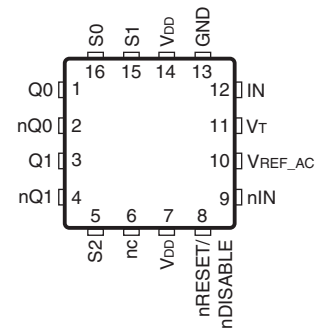

ICS889875

16-Lead VFQFN

**3mm x 3mm x 0.925mm package body
K Package
Top View**

Table 1. Pin Descriptions

Number	Name	Type		Description
1, 2	Q0, nQ0	Output		Differential output pair. Divide by 1, 2, 4, 8, or 16. Unused outputs must be terminated with 100Ω across the differential pair. LVDS interface levels.
3, 4	Q1, nQ1	Output		Differential output pair. Divide by 1, 2, 4, 8, or 16. Unused outputs must be terminated with 100Ω across the differential pair. LVDS interface levels.
5, 15, 16	S2, S1, S0	Input	Pullup	Select pins. Internal 37kΩ pullup resistor. Logic HIGH if left disconnected. Input threshold is $V_{DD}/2$. LVCMOS/LVTTL interface levels.
6	nc	Unused		No connect.
7, 14	V_{DD}	Power		Power supply pins.
8	nRESET/ nDISABLE	Input	Pullup	Synchronizing enable/disable pin. When LOW, resets the divider (divided by 1, 2, 4, 8 or 16 mode). When HIGH, disconnected. The reset and disable function occurs on the next high-to-low clock input transition. Input threshold is $V_{DD}/2V$. Includes a 37kΩ pull-up resistor. LVTTL / LVCMOS interface levels.
9	nIN	Input		Inverting differential LVPECL clock input. $R_T = 50\Omega$ termination to V_T .
10	V_{REF_AC}	Output		Reference voltage for AC-coupled applications. Equal to $V_{DD} - 1.4V$ (approx.). Maximum sink/source current is 0.5mA.
11	V_T	Input		Termination center-tap input.
12	IN	Input		Non-inverting LVPECL differential clock input. $R_T = 50\Omega$ termination to V_T .
13	GND	Power		Power supply ground.

NOTE: *Pullup* refers to internal input resistors. See Table 2, *Pin Characteristics*, for typical values.

Table 2. Pin Characteristics

Symbol	Parameter	Test Conditions	Minimum	Typical	Maximum	Units
R_{PULLUP}	Input Pullup Resistor			37		kΩ

Function Tables

Table 3A. Control Input Function Table

Input	Outputs	
nRESET	Q0, Q1	nQ0, nQ1
0	Disabled; LOW	Disabled; HIGH
1	Enabled	Enabled

NOTE: After nRESET switches, the clock outputs are disabled or enabled following a falling input clock edge as shown in *Figure 1*.

Figure 1. nRESET Timing Diagram

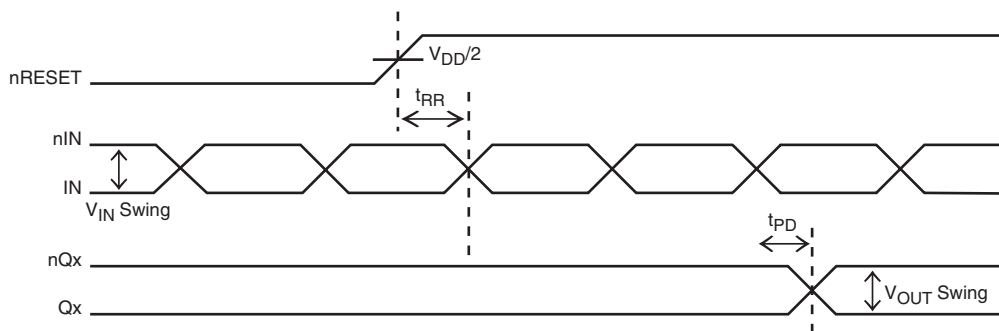

Table 3B. Truth Table

Inputs				Outputs
nRESET/nDISABLE	S2	S1	S0	Q0/nQ0, Q1/nQ1
1	0	X	X	Reference Clock (pass through)
1	1	0	0	Reference Clock $\div 2$
1	1	0	1	Reference Clock $\div 4$
1	1	1	0	Reference Clock $\div 8$
1	1	1	1	Reference Clock $\div 16$
0 (NOTE 1)	X	X	X	Qx = LOW, nQx = HIGH; Clock disabled

NOTE 1: Reset/disable function is asserted on the next clock input (IN/nIN) high-to-low transition.

Absolute Maximum Ratings

NOTE: Stresses beyond those listed under *Absolute Maximum Ratings* may cause permanent damage to the device. These ratings are stress specifications only. Functional operation of product at these conditions or any conditions beyond those listed in the *DC Characteristics* or *AC Characteristics* is not implied. Exposure to absolute maximum rating conditions for extended periods may affect product reliability.

Item	Rating
Supply Voltage, V_{DD}	4.6V
Inputs, V_I	-0.5V to $V_{DD} + 0.5V$
Outputs, I_O Continuous Current Surge Current	10mA 15mA
Input Current, I_{IN} , nI_{IN}	$\pm 50mA$
V_T Current, I_{VT}	$\pm 100mA$
Input Sink/Source, I_{REF_AC}	$\pm 0.5mA$
Operating Temperature Range, T_A	-40°C to +85°C
Package Thermal Impedance, θ_{JA} , (Junction-to-Ambient)	88.5°C/W (0 mps)
Storage Temperature, T_{STG}	-65°C to 150°C

DC Electrical Characteristics

Table 4A. Power Supply DC Characteristics, $V_{DD} = 2.5V \pm 5\%$, $T_A = -40^\circ C$ to $85^\circ C$

Symbol	Parameter	Test Conditions	Minimum	Typical	Maximum	Units
V_{DD}	Positive Supply Voltage		2.375	2.5	2.625	V
I_{DD}	Power Supply Current				82	mA

Table 4B. LVCMOS/LVTTL DC Characteristics, $V_{DD} = 2.5V \pm 5\%$, $T_A = -40^\circ C$ to $85^\circ C$

Symbol	Parameter	Test Conditions	Minimum	Typical	Maximum	Units
V_{IH}	Input High Voltage		2		$V_{DD} + 0.3$	V
V_{IL}	Input Low Voltage		0		0.8	V
I_{IH}	Input High Current	$V_{DD} = V_{IN} = 2.625V$			5	μA
I_{IL}	Input Low Current	$V_{DD} = 2.625V, V_{IN} = 0V$	-150			μA

Table 4C. Differential DC Characteristics, $V_{DD} = 2.5V \pm 5\%$, $T_A = -40^\circ\text{C}$ to 85°C

Symbol	Parameter	Test Conditions	Minimum	Typical	Maximum	Units
R_{IN}	Differential Input Resistance (IN, nIN)			100		Ω
V_{IH}	Input High Voltage (IN, nIN)		1.2		$V_{DD} + 0.05$	V
V_{IL}	Input Low Voltage (IN, nIN)		0		$V_{DD} - 0.15$	V
V_{IN}	Input Voltage Swing		0.15		2.8	V
V_{DIFF_IN}	Differential Input Voltage Swing		0.3			V
I_{IN}	Input Current (IN, nIN)				45	mA
V_{REF_AC}	Bias Voltage			$V_{DD} - 1.35$		V

Table 4D. LVDS DC Characteristics, $V_{DD} = 2.5V \pm 5\%$, $T_A = -40^\circ\text{C}$ to 85°C

Symbol	Parameter	Test Conditions	Minimum	Typical	Maximum	Units
V_{OUT}	Output Voltage Swing		250	350	400	mV
V_{OH}	Output High Voltage			1.475		V
V_{OL}	Output Low Voltage		0.925			V
V_{CCM}	Output Common Mode Voltage			1.35		V
ΔV_{OCM}	Change in Common Mode Voltage				50	mV

AC Electrical Characteristics

Table 5. AC Characteristics, $V_{DD} = 2.5V \pm 5\%$, $T_A = -40^\circ\text{C}$ to 85°C

Parameter	Symbol	Test Conditions	Minimum	Typical	Maximum	Units
f_{MAX}	Maximum Input Frequency	$\div 1, \div 2, \div 4$		>2		GHz
		$\div 8, \div 16$		>1.5		GHz
t_{PD}	Propagation Delay; NOTE 1	IN-to-Q	690		1140	ps
$t_{sk(o)}$	Output Skew; NOTE 2, 3				15	ps
$t_{sk(pp)}$	Part-to-Part Skew; NOTE 3, 4				280	ps
$f_{jit(cc)}$	Cycle-to-Cycle Jitter, RMS; NOTE 5				1	ps
$f_{jit(j)}$	Total Jitter			10		ps
t_{RR}	Reset Recovery Time		600			ps
t_R / t_F	Output Rise/Fall Time		70		260	ps

All parameters characterized at f_{MAX} unless otherwise noted.

NOTE 1: Measured from the differential input crossing point to the differential output crossing point.

NOTE 2: Defined as skew between outputs at the same supply voltage and with equal load conditions. Measured at the output differential cross points.

NOTE 3: This parameter is defined in accordance with JEDEC Standard 65.

NOTE 4: Defined as skew between outputs on different devices operating at the same supply voltages and with equal load conditions. Using the same type of inputs on each device, the outputs are measured at the differential cross points.

NOTE 5: The cycle-to-cycle jitter on the input will equal the jitter on the output. The part does not add jitter.

Parameter Measurement Information

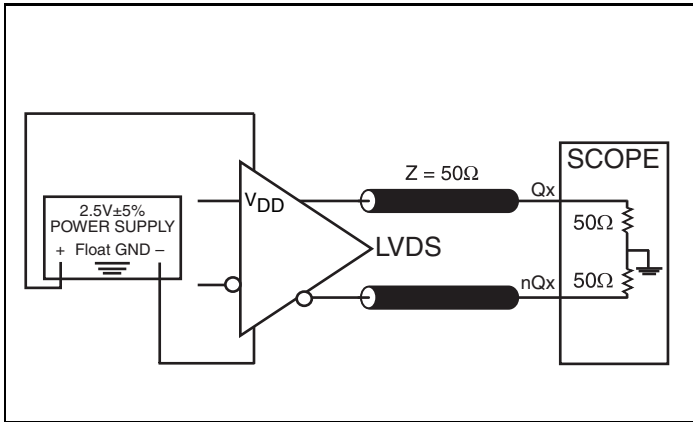

LVDS Output Load AC Test Circuit

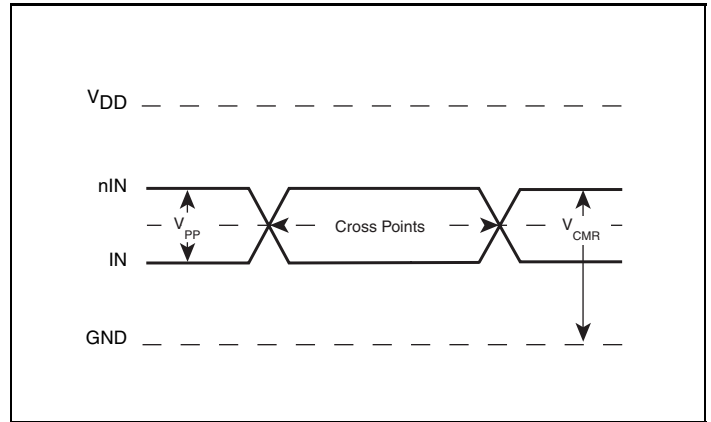

Differential Input Level

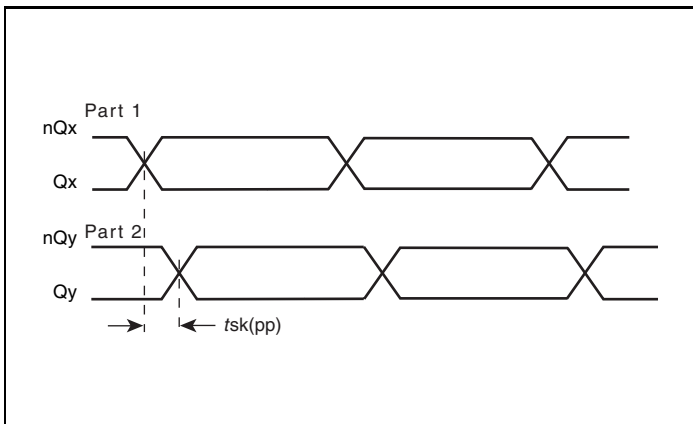

Part-to-Part Skew

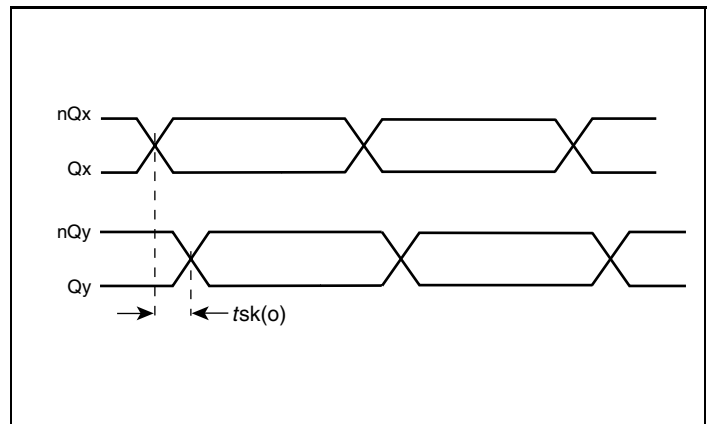

Output Skew

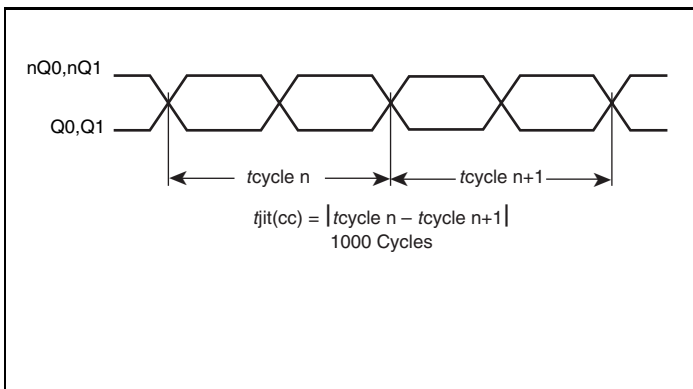

Cycle-to-Cycle Jitter, RMS

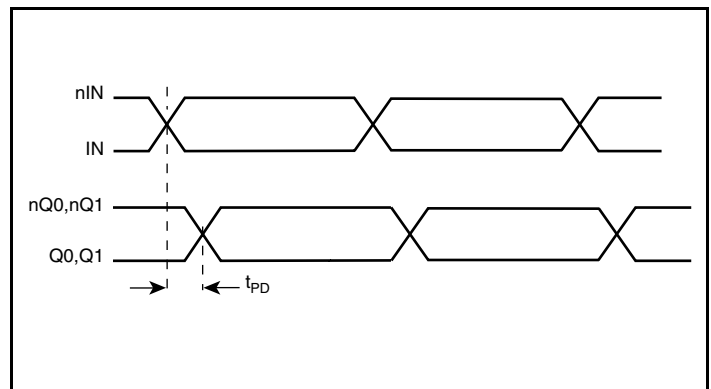

Propagation Delay

Parameter Measurement Information, continued

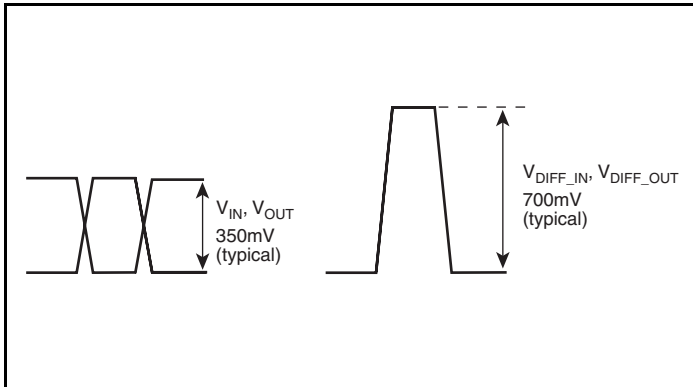

Single-Ended & Differential Input Voltage Swing

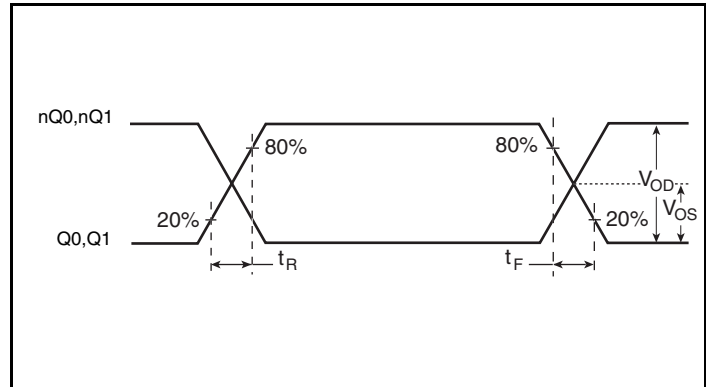

Output Rise/Fall Time

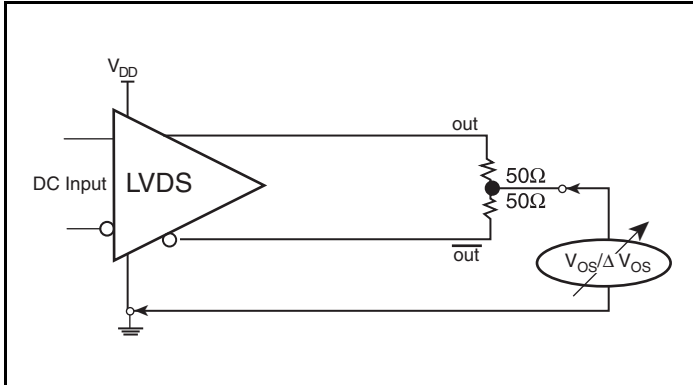

Offset Voltage Setup

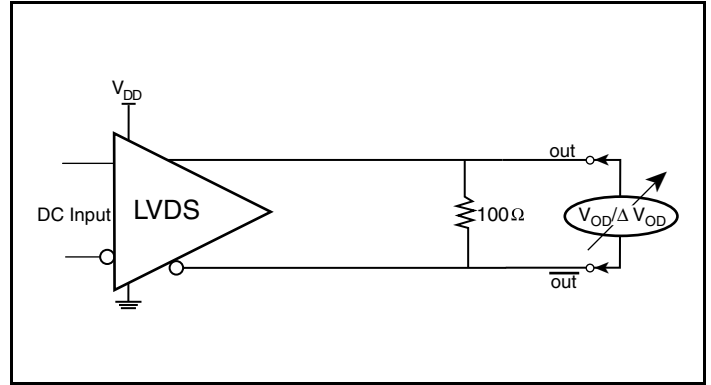

Differential Output Voltage Setup

Application Information

Wiring the Differential Input to Accept Single Ended Levels

Figure 2 shows how the differential input can be wired to accept single ended levels. The reference voltage $V_{REF} = V_{DD}/2$ is generated by the bias resistors R1, R2 and C1. This bias circuit should be located as close as possible to the input pin. The ratio of R1 and R2 might need to be adjusted to position the V_{REF} in the center of the input voltage swing. For example, if the input clock swing is only 2.5V and $V_{DD} = 3.3V$, V_{REF} should be 1.25V and $R2/R1 = 0.609$.

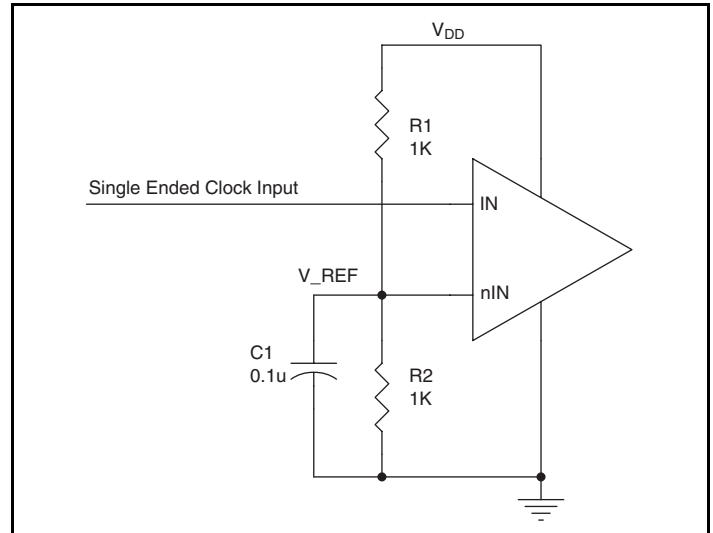

Figure 2. Single-Ended Signal Driving Differential Input

Recommendations for Unused Input Pins

Inputs:

LVC MOS Select Pins

All control pins have internal pull-ups; additional resistance is not required but can be added for additional protection. A 1kΩ resistor can be used.

Outputs:

LVDS Outputs

All unused LVDS output pairs can be either left floating or terminated with 100Ω across. If they are left floating, we recommend that there is no trace attached.

2.5V LVPECL Input with Built-In 50Ω Termination Interface

The IN /nIN with built-in 50Ω terminations accept LVDS, LVPECL, CML, SSTL and other differential signals. Both signals must meet the V_{PP} and V_{CMR} input requirements. Figures 3A to 3E show interface examples for the HiPerClockS IN /nIN with built-in 50Ω termination input driven by the most common driver types. The

input interfaces suggested here are examples only. If the driver is from another vendor, use their termination recommendation. Please consult with the vendor of the driver component to confirm the driver termination requirements.

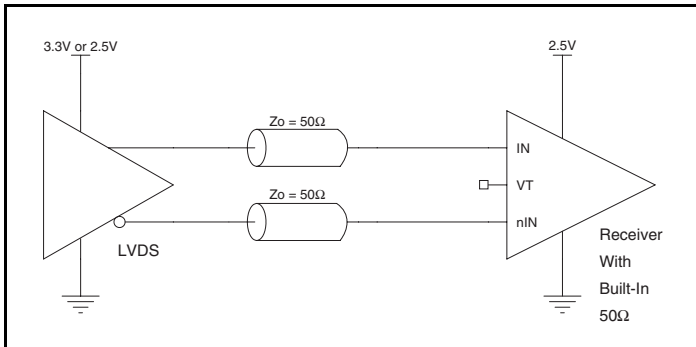

Figure 3A. HiPerClockS IN/nIN Input with Built-In 50Ω Driven by an LVDS Driver

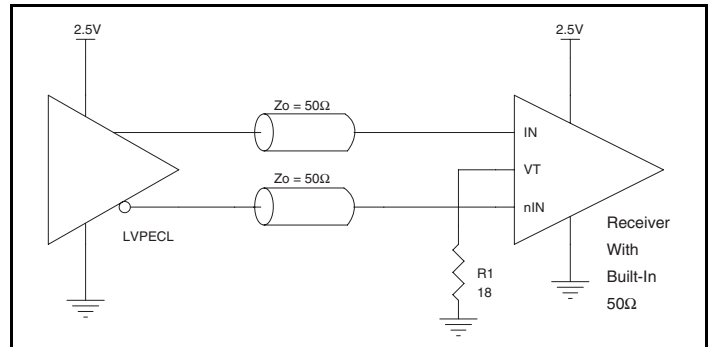

Figure 3B. HiPerClockS IN/nIN Input with Built-In 50Ω Driven by an LVPECL Driver

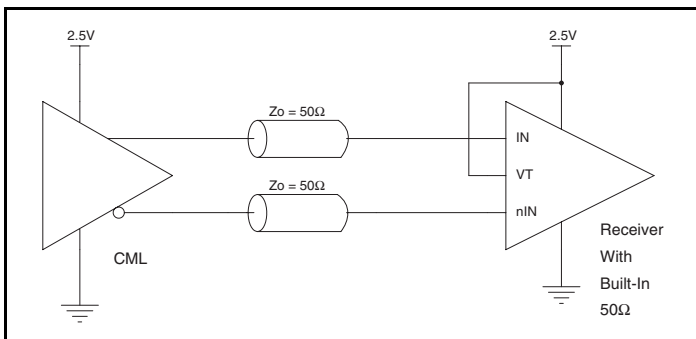

Figure 3C. HiPerClockS IN/nIN Input with Built-In 50Ω Driven by a CML Driver

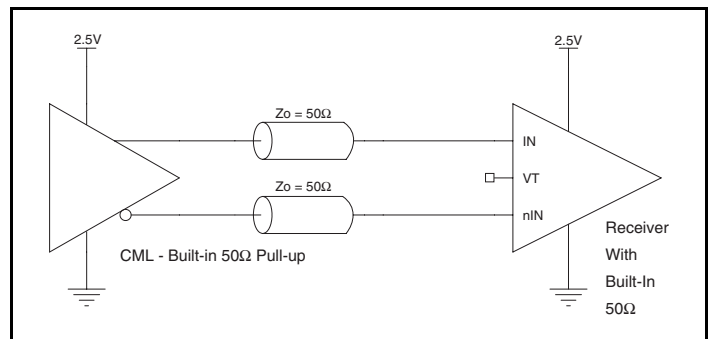

Figure 3D. HiPerClockS IN/nIN Input with Built-In 50Ω Driven by a CML Driver with Built-In 50Ω Pullup

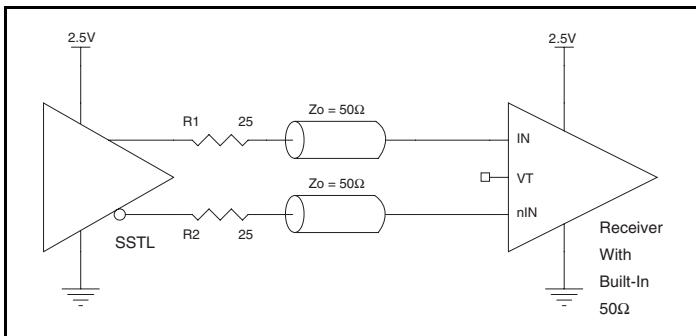

Figure 3E. HiPerClockS IN/nIN Input with Built-In 50Ω Driven by an SSTL Driver

VFQFN EPAD Thermal Release Path

In order to maximize both the removal of heat from the package and the electrical performance, a land pattern must be incorporated on the Printed Circuit Board (PCB) within the footprint of the package corresponding to the exposed metal pad or exposed heat slug on the package, as shown in *Figure 4*. The solderable area on the PCB, as defined by the solder mask, should be at least the same size/shape as the exposed pad/slug area on the package to maximize the thermal/electrical performance. Sufficient clearance should be designed on the PCB between the outer edges of the land pattern and the inner edges of pad pattern for the leads to avoid any shorts.

While the land pattern on the PCB provides a means of heat transfer and electrical grounding from the package to the board through a solder joint, thermal vias are necessary to effectively conduct from the surface of the PCB to the ground plane(s). The land pattern must be connected to ground through these vias. The vias act as “heat pipes”. The number of vias (i.e. “heat pipes”) are

application specific and dependent upon the package power dissipation as well as electrical conductivity requirements. Thus, thermal and electrical analysis and/or testing are recommended to determine the minimum number needed. Maximum thermal and electrical performance is achieved when an array of vias is incorporated in the land pattern. It is recommended to use as many vias connected to ground as possible. It is also recommended that the via diameter should be 12 to 13mils (0.30 to 0.33mm) with 1oz copper via barrel plating. This is desirable to avoid any solder wicking inside the via during the soldering process which may result in voids in solder between the exposed pad/slug and the thermal land. Precautions should be taken to eliminate any solder voids between the exposed heat slug and the land pattern. Note: These recommendations are to be used as a guideline only. For further information, please refer to the Application Note on the Surface Mount Assembly of Amkor’s Thermally/Electrically Enhance Leadframe Base Package, Amkor Technology.

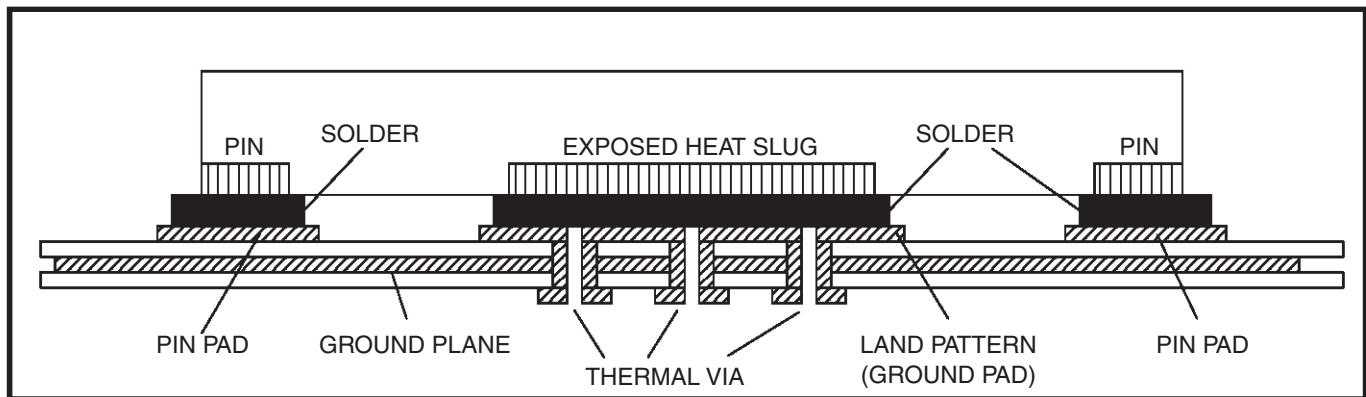

Figure 4. P.C. Assembly for Exposed Pad Thermal Release Path – Side View (drawing not to scale)

2.5V LVDS Driver Termination

Figure 5 shows a typical termination for LVDS driver in characteristic impedance of 100Ω differential (50Ω single)

transmission line environment. For buffer with multiple LDVS driver, it is recommended to terminate the unused outputs.

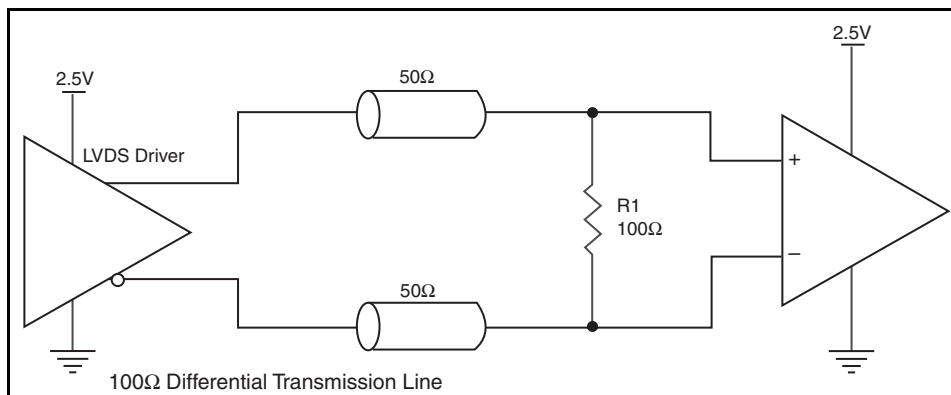

Figure 5. Typical LVDS Driver Termination

Schematic Example

Figure 6 shows a schematic example of the ICS889875. This schematic provides examples of input and output handling. The ICS889875 input has built-in 50Ω termination resistors. The input can directly accept various types of differential signals without AC coupling. For AC coupling termination, the ICS889875 also provides the V_{REF_AC} pin for proper offset bias. This example

shows the ICS889875 input driven by a 2.5V LVPECL driver. The ICS889875 outputs are LVDS drivers. In this example, we assume the traces are long transmission lines and the receivers of the LVDS drivers have high input impedance without built-in termination.

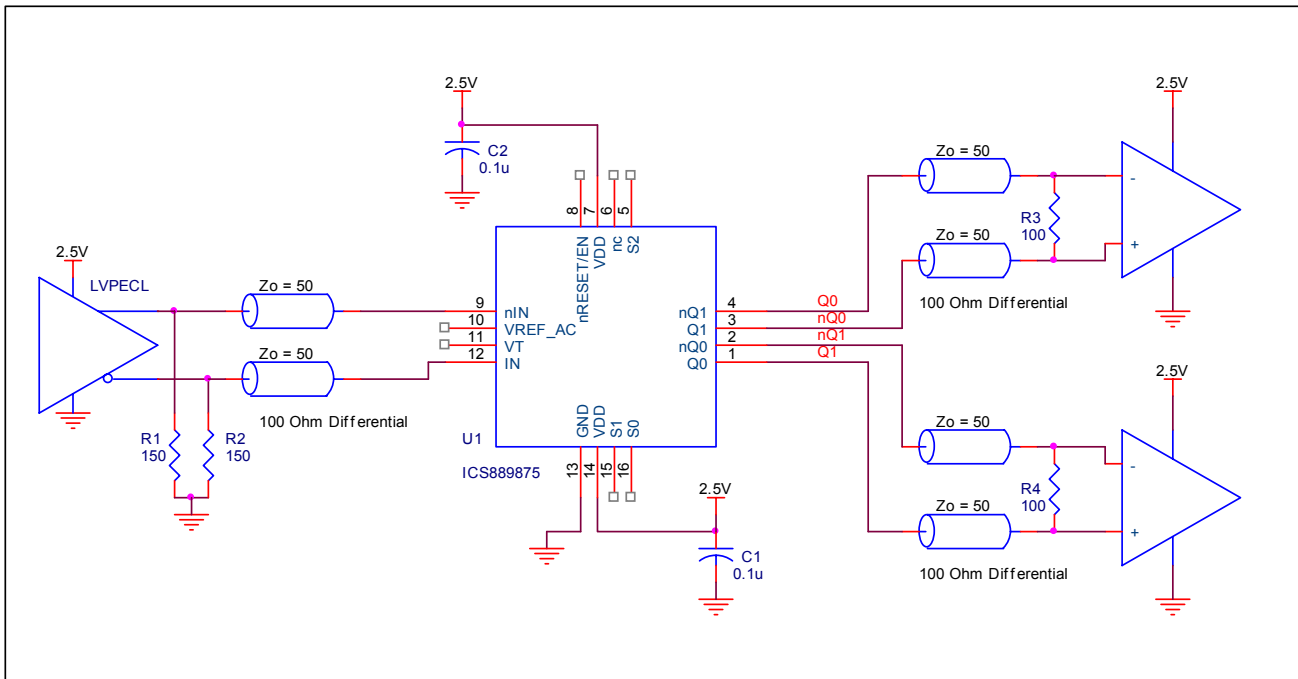

Figure 6. ICS889875 Schematic Example

Power Considerations

This section provides information on power dissipation and junction temperature for the ICS889875. Equations and example calculations are also provided.

1. Power Dissipation.

The total power dissipation for the ICS889875 is the sum of the core power plus the power dissipated in the load(s). The following is the power dissipation for $V_{DD} = 2.5V + 5\% = 2.625V$, which gives worst case results.

- $Power_{MAX} = V_{DD_MAX} * I_{DD_MAX} = 2.625V * 82mA = 215.25mW$

2. Junction Temperature.

Junction temperature, T_j , is the temperature at the junction of the bond wire and bond pad and directly affects the reliability of the device. The maximum recommended junction temperature for HiPerClockS devices is 125°C.

The equation for T_j is as follows: $T_j = \theta_{JA} * Pd_{total} + T_A$

T_j = Junction Temperature

θ_{JA} = Junction-to-Ambient Thermal Resistance

Pd_{total} = Total Device Power Dissipation (example calculation is in section 1 above)

T_A = Ambient Temperature

In order to calculate junction temperature, the appropriate junction-to-ambient thermal resistance θ_{JA} must be used. Assuming no air flow and a multi-layer board, the appropriate value is 51.5°C/W per Table 6 below.

Therefore, T_j for an ambient temperature of 85°C with all outputs switching is:

$$85^\circ C + 0.215W * 88.5^\circ C/W = 104^\circ C. \text{ This is well below the limit of } 125^\circ C.$$

This calculation is only an example. T_j will obviously vary depending on the number of loaded outputs, supply voltage, air flow and the type of board (single layer or multi-layer).

Table 6. Thermal Resistance θ_{JA} for 16 Lead VFQFN, Forced Convection

Meters per Second	θ_{JA} by Velocity		
	0	1	2.5
Multi-Layer PCB, JEDEC Standard Test Boards	88.5°C/W	77.3°C/W	69.4°C/W

Reliability Information

Table 7. θ_{JA} vs. Air Flow Table for a 16 Lead VFQFN

Meters per Second	θ_{JA} by Velocity		
	0	1	2.5
Multi-Layer PCB, JEDEC Standard Test Boards	88.5°C/W	77.3°C/W	69.4°C/W

Transistor Count

The transistor count for ICS889875 is: 328

Pin compatible with SY89875U

Package Outline and Package Dimensions

Package Outline - K Suffix for 16 Lead VFQFN

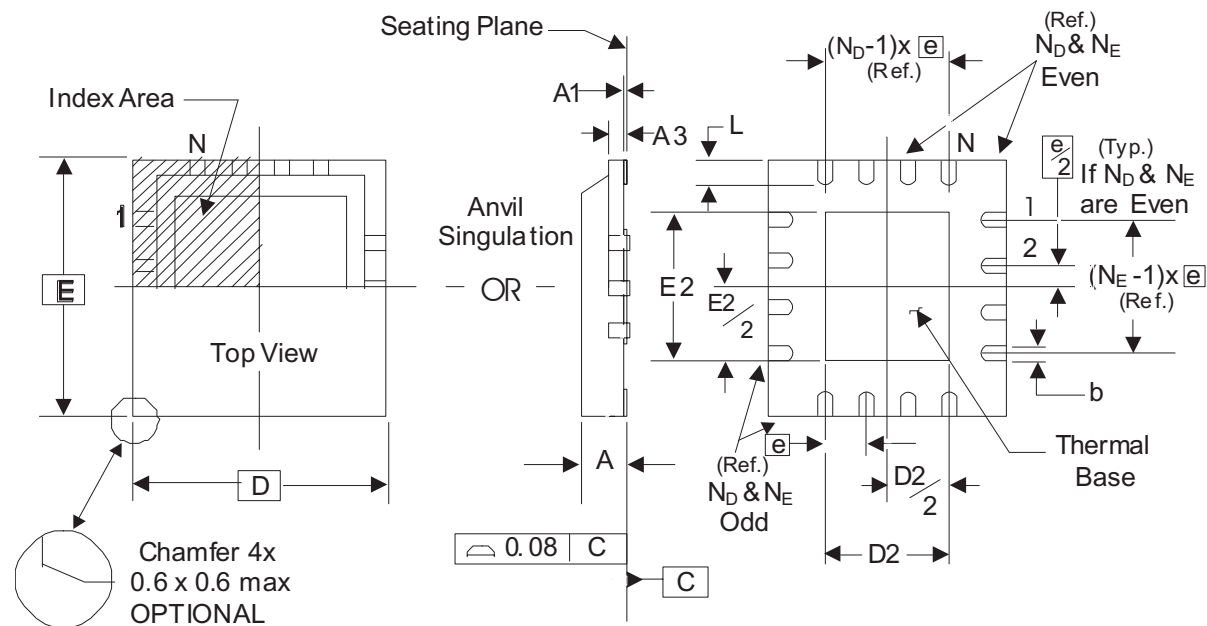

Table 8. Package Dimensions

JEDEC Variation: VEED-2/-4 All Dimensions in Millimeters		
Symbol	Minimum	Maximum
N	16	
A	0.80	1.00
A1	0	0.05
A3	0.25 Ref.	
b	0.18	0.30
N_D & N_E	4	
D & E	3.00 Basic	
D2 & E2	1.00	1.80
e	0.50 Basic	
L	0.30	0.50

Reference Document: JEDEC Publication 95, MO-220

Ordering Information

Table 9. Ordering Information

Part/Order Number	Marking	Package	Shipping Packaging	Temperature
889875AK	875A	16 Lead VFQFN	Tube	-40°C to 85°C
889875AKT	875A	16 Lead VFQFN	2500 Tape & Reel	-40°C to 85°C
889875AKLF	75AL	"Lead-Free" 16 Lead VFQFN	Tube	-40°C to 85°C
889875AKLFT	75AL	"Lead-Free" 16 Lead VFQFN	2500 Tape & Reel	-40°C to 85°C

NOTE: Parts that are ordered with an "LF" suffix to the part number are the Pb-Free configuration and are RoHS compliant.

While the information presented herein has been checked for both accuracy and reliability, Integrated Device Technology (IDT) assumes no responsibility for either its use or for the infringement of any patents or other rights of third parties, which would result from its use. No other circuits, patents, or licenses are implied. This product is intended for use in normal commercial and industrial applications. Any other applications, such as those requiring high reliability or other extraordinary environmental requirements are not recommended without additional processing by IDT. IDT reserves the right to change any circuitry or specifications without notice. IDT does not authorize or warrant any IDT product for use in life support devices or critical medical instruments.

Revision History Sheet

Rev	Table	Page	Description of Change	Date
B	T4C	5	Differential DC Characteristics Table - corrected typo for V_{IH} max. from $V_{DD} - 0.05V$ to $V_{DD} + 0.05V$.	7/1/08
B	T1	2	Pin Description Table - deleted "Leave pin floating." from VT pin description.	7/3/08

Contact Information:

www.IDT.com

Sales

800-345-7015 (inside USA)
+408-284-8200 (outside USA)
Fax: 408-284-2775
www.IDT.com/go/contactIDT

Technical Support

netcom@idt.com
+480-763-2056

Corporate Headquarters

Integrated Device Technology, Inc.
6024 Silver Creek Valley Road
San Jose, CA 95138
United States
800-345-7015 (inside USA)
+408-284-8200 (outside USA)